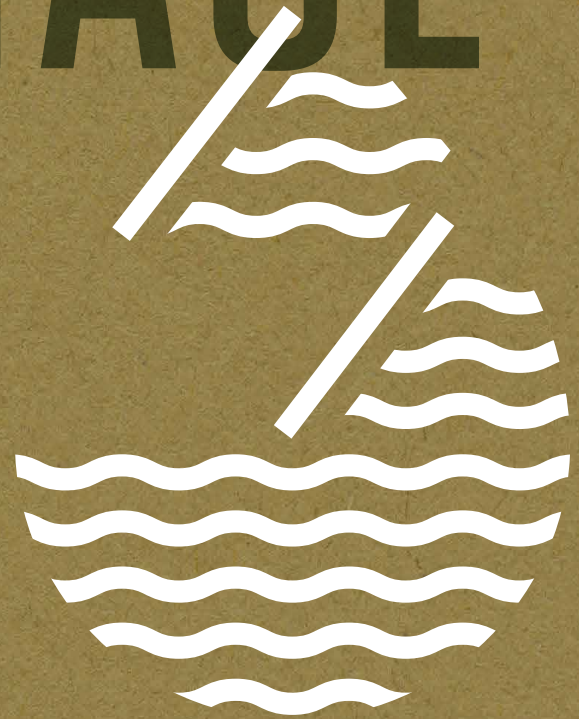


# URBAN STORM DRAINAGE

VOLUME

—  
2

CRITERIA  
MANUAL



STRUCTURES, STORAGE, AND RECREATION



# **Urban Storm Drainage Criteria Manual: Volume 2 Structures, Storage, and Recreation**

**Updated January 2016**  
Originally Published September 1969



**Urban Drainage and Flood Control District**  
2480 West 26<sup>th</sup> Avenue, Suite 156B  
Denver, Colorado 80211  
[www.udfcd.org](http://www.udfcd.org)

---

**Copyright 2016 by the Urban Drainage and Flood Control District (UDFCD).** All rights reserved. Printed and bound in the United States of America. Unless in conformance with the Permission to Use Statement below, no part of this publication may be reproduced, copied, transmitted, transcribed or stored in any form such as mechanical, electric, optical, chemical, manual or otherwise, without written permission from UDFCD or without the prior written permission of UDFCD. Requests for permission shall be directed to UDFCD at [udfcd@udfcd.org](mailto:udfcd@udfcd.org).

### Permission to Use

Permission granted to user by UDFCD for:

1. Individual, personal single copy reproduction for an individual use only, not for resale; or
2. Public agency, private organization, or trade association, in-house multi-copy reproduction for distribution and use within a single public agency, private organization, or trade association, not for resale.

Prior written approval of UDFCD is required by user for any other use.

### Restrictions Applicable to Commercial Reproduction

Commercial reproduction of individual or multiple copies, or portions thereof, is strictly prohibited without the prior written approval of UDFCD. Requests for permission shall be directed to UDFCD at: [udfcd@udfcd.org](mailto:udfcd@udfcd.org).

# Urban Storm Drainage Criteria Manual

## Contents

### Disclaimer

### Volume 1

#### Preface

- 1.0 Acknowledgements
- 2.0 Purpose
- 3.0 Overview
- 4.0 List of Abbreviations

#### Chapter 1 **Drainage Policy**

- 1.0 Policies and Principles
- 2.0 UDFCD Hydrologic Data Collection
- 3.0 Planning
- 4.0 Technical Criteria
- 5.0 Floodplain Management
- 6.0 Implementation of Urban Storm Drainage Criteria
- 7.0 References

#### Chapter 2 **Drainage Law**

- 1.0 Summary of Current General Principle of Drainage and Flood Control Law
- 2.0 General Principles of Drainage Law
- 3.0 Drainage Improvements by a Local Government
- 4.0 Financing Drainage Improvements
- 5.0 Floodplain Management
- 6.0 Special Matters
- 7.0 Conclusion

#### Chapter 3 **Planning**

- 1.0 Importance of Drainage Planning
- 2.0 Minor (Initial) Drainage System Planning
- 3.0 Drainage Master Planning Process
- 4.0 Floodplain Management
- 5.0 Multi-use Opportunities
- 6.0 References

**Chapter 4 Flood Risk Management**

- 1.0 Introduction
- 2.0 Floodplain Management Fundamentals
- 3.0 Floodplain Mapping Changes and Administration
- 4.0 Flood Insurance
- 5.0 UDFCD, Local and State Floodplain Management Programs
- 6.0 Floodproofing
- 7.0 Assistance for Property Owners
- 8.0 References
- 9.0 Glossary

**Chapter 5 Rainfall**

- 1.0 Overview
- 2.0 Rainfall Depth-Duration-Frequency
- 3.0 Design Storm Distribution for CUHP
- 4.0 Intensity-Duration Curves for Rational Method
- 5.0 Spreadsheet Design Aids
- 6.0 Examples
- 7.0 References

**Chapter 6 Runoff**

- 1.0 Overview
- 2.0 Rational Method
- 3.0 Colorado Urban Hydrograph Procedure
- 4.0 EPA SWMM and Hydrograph Routing
- 5.0 Other Hydrologic Methods
- 6.0 Software
- 7.0 Examples
- 8.0 References

**Chapter 7 Street, Inlets, and Storm Drains**

- 1.0 Introduction
- 2.0 Street Drainage
- 3.0 Inlets
- 4.0 Storm Drain Systems
- 5.0 UD-Inlet Design Workbook
- 6.0 Examples
- 7.0 References

**Chapter 8      Open Channels**

- 1.0    Introduction
- 2.0    Natural Stream Corridors
- 3.0    Preserving Natural Stream Corridors
- 4.0    Stream Restoration Principles
- 5.0    Naturalized Channels
- 6.0    Swales
- 7.0    Hydraulic Analysis
- 8.0    Rock and Boulders
- 9.0    References

**Volume 2****Chapter 9      Hydraulic Structures**

- 1.0    Structures in Streams
- 2.0    Grade Control Structures
- 3.0    Pipe Outfalls and Rundowns
- 4.0    References

**Chapter 10     Stream Access and Recreational Channels**

- 1.0    Introduction and Overview
- 2.0    Public Safety Project Review
- 3.0    Paths Adjacent to Streams
- 4.0    In-Channel Safety
- 5.0    References

**Chapter 11     Culverts and Bridges**

- 1.0    Introduction and Overview
- 2.0    Required Design Information
- 3.0    Culvert Hydraulics
- 4.0    Culvert Sizing and Designs
- 5.0    Culvert Inlets
- 6.0    Outlet Protection
- 7.0    Bridges
- 8.0    Design Examples
- 9.0    Checklist
- 10.0    References

**Chapter 12 Storage**

- 1.0 Overview
- 2.0 Implementation of Regional, Sub-regional, and On-site Detention Facilities
- 3.0 Full Spectrum Detention as the Recommended Approach
- 4.0 Sizing of Full Spectrum Detention Storage Volumes
- 5.0 Design Considerations
- 6.0 Additional Configurations of Detention Facilities
- 7.0 Designing for Operations and Maintenance
- 8.0 Design Examples
- 9.0 References

**Chapter 13 Revegetation**

- 1.0 Introduction
- 2.0 Habitat Types
- 3.0 Site Preparation
- 4.0 Plant Material Selection
- 5.0 Plant Installation
- 6.0 Mulching
- 7.0 Maintenance
- 8.0 Post-construction Monitoring
- 9.0 Conclusion
- 10.0 References

# Disclaimer

## **Attention all persons using the Urban Storm Drainage Criteria Manual (USDCM), its Design Form Spreadsheets, AutoCAD™ Details, and Related Software Products:**

The products listed above have been developed using a high standard of care, including professional review for identification of errors, bugs, and other problems related to the software. However, as with any release of publications, details, and software, errors will be discovered. The developers of these products welcome user feedback in helping to identify them so that improvements can be made to future releases of this manual and all related products.

This manual and all related products are intended to assist and streamline the planning and design process of drainage facilities. The AutoCAD™ details are intended to show design concepts. Preparation of final design plans, addressing details of structural adequacy, public safety, hydraulic functionality, maintainability, and aesthetics, remain the sole responsibility of the designer.

**By the use of the USDCM and/or related design form worksheets, spreadsheets, AutoCAD™ details, software and all other related products, the user agrees to the following:**

### **DISCLAIMER OF WARRANTIES AND DAMAGES**

THE USDCM, ITS DESIGN FORM SPREADSHEETS, AUTO CAD<sup>TH</sup> DETAILS AND RELATED SOFTWARE ARE PROVIDED BY URBAN DRAINAGE AND FLOOD CONTROL DISTRICT (“UDFCD”) AND ITS CONTRACTORS, ADVISORS, REVIEWERS AND MEMBER GOVERNMENTAL AGENCIES (“CONTRIBUTORS”) “**AS IS**” AND “**WITH ALL FAULTS**”. ANY EXPRESS OR IMPLIED WARRANTIES, INCLUDING, BUT NOT LIMITED TO, THE IMPLIED WARRANTIES OF MERCHANTABILITY AND FITNESS FOR A PARTICULAR PURPOSE ARE DISCLAIMED. IN NO EVENT SHALL UDFCD OR ITS CONTRIBUTORS BE LIABLE FOR ANY DIRECT, INDIRECT, INCIDENTAL, SPECIAL, EXEMPLARY, OR CONSEQUENTIAL DAMAGES (INCLUDING, BUT NOT LIMITED TO, PROCUREMENT OF SUBSTITUTE GOODS OR SERVICES; LOSS OF USE, DATA, INFORMATION OR PROFITS; OR BUSINESS INTERRUPTION) HOWEVER CAUSED AND ON ANY THEORY OF LIABILITY, WHETHER IN CONTRACT, STRICT LIABILITY, OR TORT (INCLUDING NEGLIGENCE OR OTHERWISE) ARISING IN ANY WAY OUT OF THE USE OF THE USDCM, ITS DESIGN FORM SPREADSHEETS, AUTOCAD<sup>TM</sup> DETAILS, AND RELATED SOFTWARE.



# Chapter 9

## Hydraulic Structures

### Contents

<b>1.0</b>	<b>Structures in Streams .....</b>	<b>1</b>
<b>2.0</b>	<b>Grade Control Structures.....</b>	<b>2</b>
2.1	Overview.....	2
2.2	Simplified Design Procedures for Drop Structures .....	4
2.2.1	Introduction.....	4
2.2.2	Geometry.....	5
2.2.3	Unit Discharge .....	6
2.2.4	Longitudinal Slope of the Drop Structure Face.....	6
2.2.5	Stilling Basin.....	6
2.2.6	Seepage Analysis and Cutoff Wall Design .....	7
2.2.7	Low-flow Channel .....	8
2.3	Detailed Drop Structure Hydraulic Analysis.....	8
2.3.1	Introduction.....	8
2.3.2	Cross Section Placement.....	9
2.3.3	Mannings’s Roughness Coefficient for Drop Structures.....	10
2.3.4	Hydraulic Jump Formation .....	11
2.3.5	Hydraulic Jump Length.....	13
2.3.6	Evaluation of Low-flow Channel versus Overbanks.....	14
2.3.7	Evaluate Additional Return Period Flow Rates .....	15
2.3.8	Rock Sizing for Drop Approach and Downstream of End Sill .....	15
2.4	Seepage Control .....	15
2.4.1	Introduction.....	15
2.4.2	Weep Drains.....	15
2.4.3	Lane’s Weighted Creep Method .....	15
2.4.4	Foundation/Seepage Control Systems.....	17
2.5	Detailed Force Analysis .....	18
2.6	Grouted Stepped Boulder Drop Structures.....	23
2.6.1	Description.....	23
2.6.2	Structure Complexity .....	23
2.6.3	Design Criteria .....	23
2.6.4	Construction Guidance.....	25
2.7	Sculpted Concrete Drop Structure.....	32
2.7.1	Description.....	32
2.7.2	Structure Complexity .....	32
2.7.3	Design Criteria .....	33
2.7.4	Decorative Elements (Finishing).....	36
2.7.5	Construction Guidance.....	40
2.8	Vertical Drop Structure Selection .....	49
2.8.1	Description.....	49
2.8.2	Design Criteria .....	49
2.9	Low-flow Drop Structures and Check Structures .....	54
<b>3.0</b>	<b>Pipe Outfalls and Rundowns.....</b>	<b>58</b>
3.1	Pipe End Treatment.....	58
3.1.1	Flared-End Sections and Toe Walls.....	58

3.1.2	Concrete Headwall and Wingwalls .....	59
3.2	Energy Dissipation and Erosion Protection .....	65
3.2.1	Riprap Apron .....	66
3.2.2	Low Tailwater Basin.....	71
3.2.3	Rock Sizing for Riprap Apron and Low Tailwater Basin.....	73
3.2.4	Outfalls and Rundowns.....	75
3.2.5	Rundowns .....	86
<b>4.0</b>	<b>References.....</b>	<b>87</b>

<b>Appendix A. Force Analysis for Grade Control Structures.....</b>	<b>95</b>
---	-----------

## Tables

Table 9-1. Design criteria for drop structures using simplified design procedures.....	5
Table 9-2. Approximate Manning’s roughness at design discharge for stepped drop structure .....	10
Table 9-3. Lane’s weighted creep: Recommended minimum ratios .....	17
Table 9-4. Boulder sizes for various rock sizing parameters .....	25
Table 9-5. Comparison of concrete and shotcrete .....	35
Table 9-6. Nominal limit of maximum pressure fluctuations within the hydraulic jump (Toso 1986) .....	97

## Figures

Figure 9-1. Stilling basin length based on unit discharge (for simplified design procedure).....	7
Figure 9-2. Sample HEC_RAS profile with cross section locations for hydraulic analysis .....	9
Figure 9-3. Recommended Manning’s n for flow over B24 to B42 grouted boulders.....	11
Figure 9-4. Length in terms of sequent depth of jumps in horizontal channels .....	13
Figure 9-5. Stilling basin profile .....	14
Figure 9-6. Sample HEC-RAS output for cross section located at drop crest.....	14
Figure 9-7. Sheet pile cutoff wall upstream of drop structure.....	19
Figure 9-8. Sheet pile cutoff wall connections between boulders.....	20
Figure 9-9. Concrete or grout cutoff wall upstream of drop structure .....	21
Figure 9-10. Weep drains .....	22
Figure 9-11. Example plan view of basic grouted stepped boulder drop structure .....	27
Figure 9-12. Cross sections of basic grouted stepped boulder drop structure.....	28
Figure 9-13. Cross sections of basic grouted stepped boulder drop structure.....	29
Figure 9-14. Example of complex grouted stepped boulder drop structure .....	30
Figure 9-15. Grouted boulder placement detail.....	31
Figure 9-16. Example plan view of basic sculpted concrete drop structure.....	42
Figure 9-17. Example profiles of basic sculpted concrete drop structure .....	43
Figure 9-18. Example cross sections of basic sculpted concrete drop structure .....	44
Figure 9-19. Example plan view of complex sculpted concrete drop structure .....	45
Figure 9-20. Example detailed view of complex sculpted concrete drop structure.....	46
Figure 9-21. Rebar placement for sculpted concrete drop structures .....	47
Figure 9-22. Structure edge wall details.....	48
Figure 9-24. Example vertical drop structure plan.....	52
Figure 9-25. Example vertical drop structure sections.....	53
Figure 9-26. Check structure details (Part 1 of 3) .....	55

Figure 9-27. Check structure details (Part 2 of 3).....	56
Figure 9-28. Check structure details (Part 3 of 3).....	57
Figure 9-29. Flared end section (FES) headwall concept.....	60
Figure 9-30. Flared end section (FES) headwall concept.....	61
Figure 9-31. Pipe headwall concept.....	62
Figure 9-32. Pipe headwall with boulders concept.....	63
Figure 9-33. Pipe headwall/wingwall concept.....	64
Figure 9-34. Riprap apron detail for culverts in-line with the channel.....	68
Figure 9-35. Expansion factor for circular conduits.....	69
Figure 9-36. Expansion factor for rectangular conduits.....	70
Figure 9-37. Low tailwater riprap basin.....	72
Figure 9-38. Riprap erosion protection at circular conduit outlet (valid for $Q/D2.5 \leq 6.0$ ).....	74
Figure 9-39. Riprap erosion protection at rectangular conduit outlet (valid for $Q/WH1.5 \leq 8.0$ ).....	75
Figure 9-40. Boulder outfall detail.....	76
Figure 9-41. Boulder outfall detail (in-line with channel).....	77
Figure 9-42. Impact stilling basin for pipes smaller than 18” in diameter.....	81
Figure 9-43. Modified impact stilling basin for conduits 18” to 48” in diameter (Part 1 of 2).....	82
Figure 9-44. Modified impact stilling basin for conduits 18” to 48” in diameter (Part 2 of 2).....	83
Figure 9-45. UDFCD modified USBR type VI impacts stilling basin (general design dimensions).....	84
Figure 9-46. Basin width diagram for the USBR type VI impact stilling basin.....	85

## Appendix A

Figure A-1. Coefficient of pressure fluctuation, $C_p$ , at hydraulic jump.....	98
Figure A-2. Coefficient of pressure fluctuation, $C_p$ , normalized for consideration of slope and jump beginning slope.....	99



## 1.0 Structures in Streams

Hydraulic structures are used to guide and control water flow in streams. Structures described in this chapter consist of grade control structures and outfall structures for various applications and conditions.

The discussion of grade control structures in this chapter addresses the hydraulic design and grouted boulder, sculpted concrete, and vertical drop structures, whereas the *Open Channels* chapter discusses the placement of grade control structures in the stream and the *Stream Access and Recreational Channels* chapter covers safety considerations relevant to all urban streams and specialized design of boatable hydraulic structures.



**Photograph 9-1.** This grouted boulder drop structure exemplifies the opportunity available for creating an attractive urban hydraulic setting for a riparian corridor.

The outfalls section provides design guidance for various types of pipe end treatment and rock protection to dissipate hydraulic energy at outfalls of storm drains and culverts. Related design information is covered in the *Streets, Inlets, and Storm Drains* and *Culverts and Bridges* Chapters.

Considered environmental, ecological, and public safety objectives in the design of each structure. The proper application of hydraulic structures can reduce initial and future maintenance costs by managing the character of the flow to best meet all project needs.

The shape, size, and features of hydraulic structures vary widely for different projects, depending upon the design discharge and functional needs of the structure. Hydraulic design procedures discussed herein govern design of all structures. For the design of unique structures that may not fit the guidance provided, hydraulic physical modeling or computational fluid dynamics (CFD) modeling may be beneficial.

### Guidance for Using this Chapter

- Determine if the project can be designed using the simplified method (Section 2.2) or if a detailed design is required (Section 2.3).
- Perform soils and seepage analyses as necessary for the design of the foundation and seepage control system (Section 2.4). Additional analysis of forces acting on a structure may be necessary and should be evaluated on a case-by-case basis (Section 2.5).
- Use criteria specific to the type of drop structure to determine the final flow characteristics, dimensions, material requirements, and construction methods. Refer to Section 2.6 for Grouted Stepped Boulder (GSB) drop structures or to Section 2.7 for Sculpted Concrete (SC) drops.
- Refer to the *Trails and Recreations Channels* chapter for design of boatable structures and other criteria required for public safety.

## 2.0 Grade Control Structures

### 2.1 Overview

As discussed in the *Open Channels* Chapter, urbanization increases the rate, frequency and volume of runoff in natural streams and, over time, this change in hydrology may cause streambed degradation, otherwise known as down cutting or head cutting. Stabilization improvements to the stream are necessary prior to or concurrent with development in the watershed. Stream stabilization is the third step of the *Four Step Process to Stormwater Management* (see Chapter 1 of Volume 3 of this manual).

“Drop structures” are broadly defined. Drop structures provide protection for high velocity hydraulic conditions that allow a drop in channel grade over a relatively short distance. They provide controlled and stable locations for a hydraulic jump to occur, allowing for a more stable channel downstream where flow returns to subcritical. This chapter provided specific design guidance for the following basic categories of drop structures:

- Grouted stepped boulder (GSB) drop structures
- Sculpted concrete (SC drop structures
- Vertical drop structures

The design of the drop structure crest and the provision for the low flow channel directly affect the ultimate configuration of the upstream reach. A higher unit flow will pass through the low flow area than will pass through other portions of the stream cross section. Consider the situation in design to avoid destabilization of the drop structure and the stream. It is also important to consider the major flood, the path of which frequently extends around structure abutments.

Design grade control structures for fully developed future basin conditions, in accordance with zoning maps, master plans, and other relevant documents. The effects of future hydrology and potential down cutting will negatively impact the channel.



**Photograph 9-2.** Grouted stepped boulder drop structures such as this one in Denver’s Bible Park can be safe, aesthetically pleasing, and provide improved aquatic habitat besides performing their primary hydraulic function of energy dissipation.

There are two fundamental systems of a drop structure that require design consideration: the hydraulic surface-drop system and the foundation and seepage control system. The surface drop system is based on project objectives, stream stability, approach hydraulics, downstream tailwater conditions, height of the drop, public safety, aesthetics, and maintenance considerations. The material components for the foundation and seepage control system are a function of soil and groundwater conditions. One factor that influences both systems is the potential extent of future downstream channel degradation. Such degradation could cause the drop structure to fail.

See the *Stream Access and Recreational Channels* chapter for special design issues associated with drop structures in boatable channels.

Drops in series require full energy dissipation and return to normal depth between structures or require specialized design beyond the scope of this manual.

Evaluate drop structures during and after construction. Secondary erosion tendencies will necessitate additional bank and bottom protection. It is advisable to establish construction contracts and budgets with this in mind.

The sections that follow provide guidance on drop structure design using either a simplified design method or a more detailed hydraulic design method. The designer must evaluate each method and determine which is appropriate for the specific project.

#### **Key Considerations during Planning and Early Design of a Drop Structure**

- Identify the appropriate range of drop height based on the stable channel slope (as provided in the master plan or based on guidance provided in the *Open Channels* chapter). Limit the net drop height to five feet or less to avoid excessive kinetic energy and avoid the appearance of a massive structure. Vertical drops should not exceed 3 feet at any location to minimize the risk of injury from falling. With a 12-inch stilling basin, this limits the net drop height to two feet.
- Design with public safety in mind. Structures located in streams where boating, including tubing, is anticipated require additional considerations. See the *Stream Access and Recreational Channels* chapter.
- Begin the process of obtaining necessary environmental permits, such as a Section 404 permit, early in the project.
- Evaluate fish passage requirements when applicable. This may also be a requirement of environmental permits.

## 2.2 Simplified Design Procedures for Drop Structures

### 2.2.1 Introduction

The simplified design procedure can be used for grade control structures meeting design criteria provided in Table 9-1 and where all of the following criteria are met:

- Maximum unit discharge for the design event (typically the 100-year) over any portion of the drop structure is 35 cfs/ft or less,
- Net drop height (upstream channel invert less downstream channel invert exclusive of stilling basin depth) is 5 feet or less,
- Drop structure is constructed of GSB or SC,
- Drop structure is located within a tangent section and at least twice the distance of the width of the drop at the crest both upstream and downstream from a point of curvature,
- Drop structure is located in a reach that has been evaluated per the design requirements of the *Open Channel* chapter.

The simplified design procedures provided herein do not consider channel curvature, effects of other hydraulic structures, or unstable beds. If any of these conditions exist or the criteria above are not met, a detailed analysis is required per Section 2.3. Even if the criteria are met and the simplified design procedures are applied, checking the actual hydraulics of the structure using the detailed comprehensive hydraulic analysis may yield useful design insight.

There is a basic arrangement of upstream channel geometry, crest shape, basin length, and downstream channel configuration that will result in optimal energy dissipation. The following sections present simplified relationships that provide basic configuration and drop sizing parameters that may be used when the above criteria are met.

### 2.2.2 Geometry

Table 9-1 below summarizes the specific design and geometric parameters applicable to drop structures designed using the simplified design procedures. Additional discussion is provided in the sections following for some of the specific parameters summarized in the table. Graphical depiction of the geometric parameters listed in Table 9-1 can be found in Figure 9-11 through 9-14 for GSB drop structures and Figures 9-16 through 9-21 for SC drop structures.

**Table 9-1. Design criteria for drop structures using simplified design procedures**

Design Parameter	Requirement to Use Simplified Design Procedures	
	GSB Drop Structure	SC Drop Structure
Maximum Net Drop Height ( $H_d$ )	5 feet <sup>1</sup>	
Maximum Unit Discharge over any Portion of Drop Width	35 cfs per foot of drop width (see Section 2.2.3)	
Maximum Longitudinal Slope (Steepest Face Slope)	4(H):1(V) (see Section 2.2.4 for additional discussion)	
Minimum Stilling Basin Depression ( $D_b$ )	1 foot (see Section 2.2.6 for additional discussion and requirements for non-cohesive soils)	2 feet (see Section 2.2.6 for additional discussion and requirements for non-cohesive soils)
Minimum Length of Approach Riprap ( $L_a$ ):	8 feet	
Minimum Stilling Basin Length ( $L_b$ ):	Determine using Figure 9-1 (see Section 2.2.4)	
Minimum Stilling Basin Width (B)	same as crest width	
Minimum Cutoff Wall Depth	6 feet (for cohesive soils only, see Section 2.2.6 for additional discussion)	
Minimum Length of Riprap Downstream of Stilling Basin	10 feet	
Minimum $D_{50}$ for Approach and Downstream Riprap	12 inches	
Minimum Boulder Size for Drop Structure	Per Figure 9-1	N/A

<sup>1</sup>This is considered a large drop structure and is only appropriate where site specifics do not accommodate installation of smaller drop structures. Urban Drainage and Flood Control District (UDFCD) recommends the height of the drop structure not exceed 3 feet.

### 2.2.3 Unit Discharge

The unit discharge is an important design parameter for evaluating the hydraulic performance of a drop structure. In order to use the simplified design procedures, the design event maximum unit discharge over any portion of the drop structure width is 35 cfs/ft. This value is derived from recommended values for velocity and depth listed in the *Open Channels* chapter. Typically, this maximum unit discharge will occur in the low-flow channel, but in rare circumstances may be in the overbanks. Determine the design unit discharge at the crest of the drop structure and at a channel cross section 20 to 50 feet upstream of the crest. Depending on the depth of the low-flow channel at these two locations, the unit discharge could differ at the sections. Normally, the maximum unit discharge of the cross sections and exercise judgement regarding the appropriate unit discharge used for the drop structure design. Further discussion on the hydraulic evaluation of a channel cross section is in Section 2.3.6.

### 2.2.4 Longitudinal Slope of the Drop Structure Face

The longitudinal slope of the structure face should be no steeper than 4(H):1(V), while even flatter slopes will improve safety. Flatter longitudinal face slopes (i.e., flatter than 8(H):1(V), help to mitigate overly retentive hydraulics at higher tailwater depths that can cause submerged hydraulic jump formation and create reverse rollers with “keeper” waves which are a frequent cause of drowning deaths in rivers. Where possible roughen the face of the drop by developing a series of slopes rather than a smooth surface. Individual steps and differences in vertical elevation should be no greater than 3 feet in any location to limit consequence associated with slip and fall during dry conditions. The *Stream Access and Recreational Channels* chapter provides additional longitudinal slope considerations for water-based recreation and in-channel safety as well as other avoidance techniques for overly-retentive drop structures.

#### Overly Retentive Hydraulics

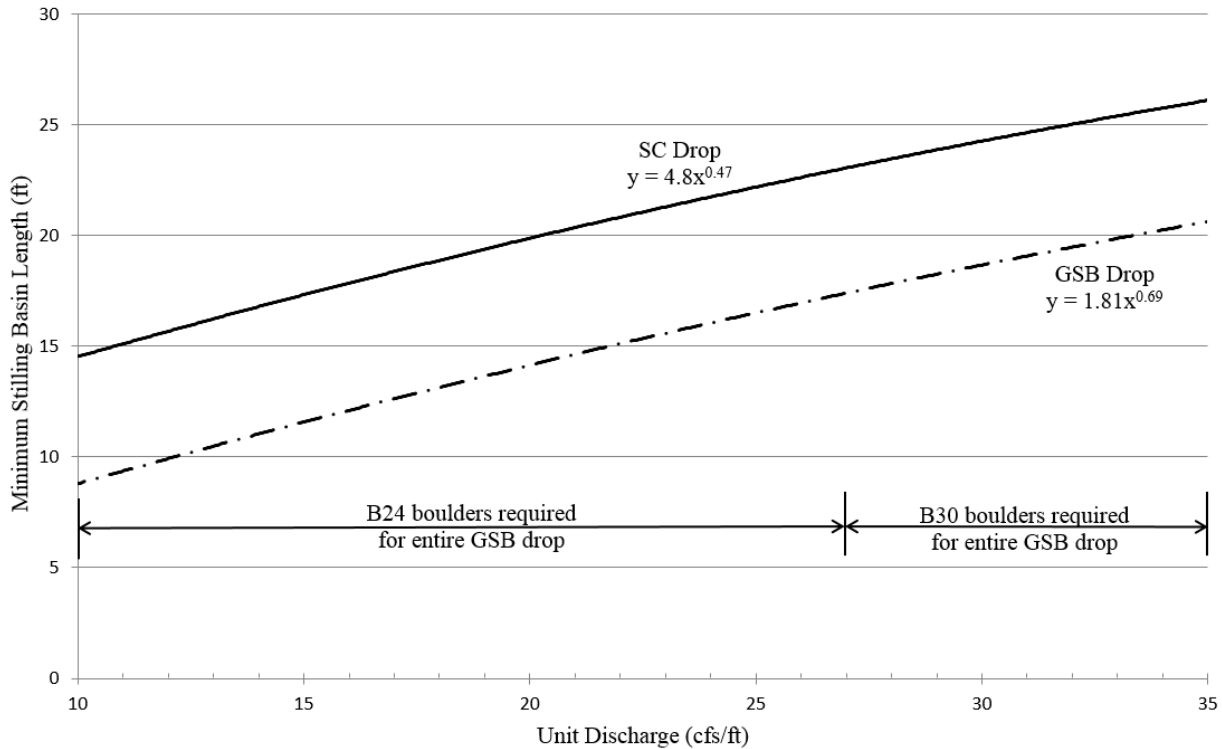
Drop faces should have a longitudinal slope no steeper than 4(H):1(V). The formation of overly retentive hydraulics is a major drowning safety concern when constructing drop structures. Longitudinal slope, roughness and drop structure shape all impact the potential for dangerous conditions. See the *Stream Access and Recreational Channels* chapter for additional criteria.

### 2.2.5 Stilling Basin

Typically, drop structures include a hydraulic jump dissipater basin. The stilling basin should be depressed in order to start the jump near the toe of the drop face, per the requirements in Table 9-1. A sill should be located at the basin end to create a transition to the downstream invert elevation. The profiles for GSB (Figure 9-12) and SC (Figure 9-17) drop structures include options for both non-draining and draining stilling basins. Where it is undesirable to have standing water, provide an opening in the end sill.

When using the simplified design, the length of the stilling basin ( $L_b$ ) can be determined using Figure 9-1. Figure 9-1 provides the required stilling basin length for both GSB and SC drop structures up to a unit discharge of 35 cfs/ft. If the proposed drop structure does not fit within the requirements of the simplified design, complete a detailed hydraulic analysis as described in Section 2.3.

In non-cohesive soil channels and channels where future degradation is expected, especially where there is no drop structure immediately downstream, it is generally recommended that the stilling basin be eliminated and the sloping face extended five feet below the downstream future channel invert elevation (after accounting for future streambed degradation). A scour hole will form naturally downstream of a structure in non-cohesive soils and construction of a hard basin is an unnecessary cost. Additionally, a hard basin would be at risk for undermining. See Figure 9-12 for the profile of the GSB and Figure 9-17 for that of an SC in this configuration. In some cases, the structure may have a net drop height of zero immediately after construction, but is designed with a long-term net height of 3 to 5 feet to accommodate future lowering of the channel invert.



**Figure 9-1. Stilling basin length based on unit discharge (for simplified design procedure)**

### 2.2.6 Seepage Analysis and Cutoff Wall Design

The simplified drop structure design only applies to drops with cutoffs located in cohesive soils. Therefore, it is necessary to determine surface and subsurface soil conditions in the vicinity of a proposed drop structure prior to being able to use the simplified approach for cutoff design. For a drop structure constructed in cohesive soils meeting all requirements of a simplified design, the cutoff wall must be a minimum of six feet deep for concrete and ten feet deep for sheet pile.

If a proposed drop structure meets the requirements of the simplified approach, but is located in non-cohesive soils, guidance on determining the required cutoff wall depth is described in Section 2.4.

The vertical seepage cutoff wall should be located upstream of the crest and can be constructed of either concrete or sheet pile. One of the most important details for grade control structures involves the interface between the seepage cutoff wall and the remainder of the structure.

Regardless, of the material used for the cutoff wall, the structure should completely bury the interface between the wall and structure. This eliminates the unattractive view of the cutoff wall within the drop structure and provides a more effective seal at the interface. To ensure a good seal, specify that the contractor must fully clean the surface of the cutoff wall prior to the construction of the interface.

Figures 9-7 through 9-9 provide multiple options (for both GSB and SC drop structures) for connecting the vertical cutoff wall to the drop structure. Additionally, the cutoff wall should extend beyond the low-flow channel and five to ten feet into the bank on each side of the structure as shown in Figure 9-27.



**Photograph 9-4.** View of the sheet pile cutoff wall and steel reinforcement for a sculpted concrete drop structure prior to the concrete placement. Note the steel reinforcement has been spot welded to the sheet pile.

Take special care when designing cutoff walls for drops in series. This typically requires a deeper wall or a wall at each crest.

### 2.2.7 Low-flow Channel

The crest of the drop structure is frequently shaped similarly to, although sometimes slightly shallower than, the upstream low-flow channel. It is also typical that the shape transition along the face of the structure in an effort to disperse the flow and dissipate energy over the width of the drop structure. This geometry is recommended unless the stream is boatable. The low-flow channel can then be re-established beyond the end sill of the drop structure. In some circumstances protection in the low-flow channel may need to extend further downstream than protection in the main channel. This should be evaluated on a case-by-case basis. When the stream is boatable, it is typically preferred that flows remain concentrated through the drop.

## 2.3 Detailed Drop Structure Hydraulic Analysis

### 2.3.1 Introduction

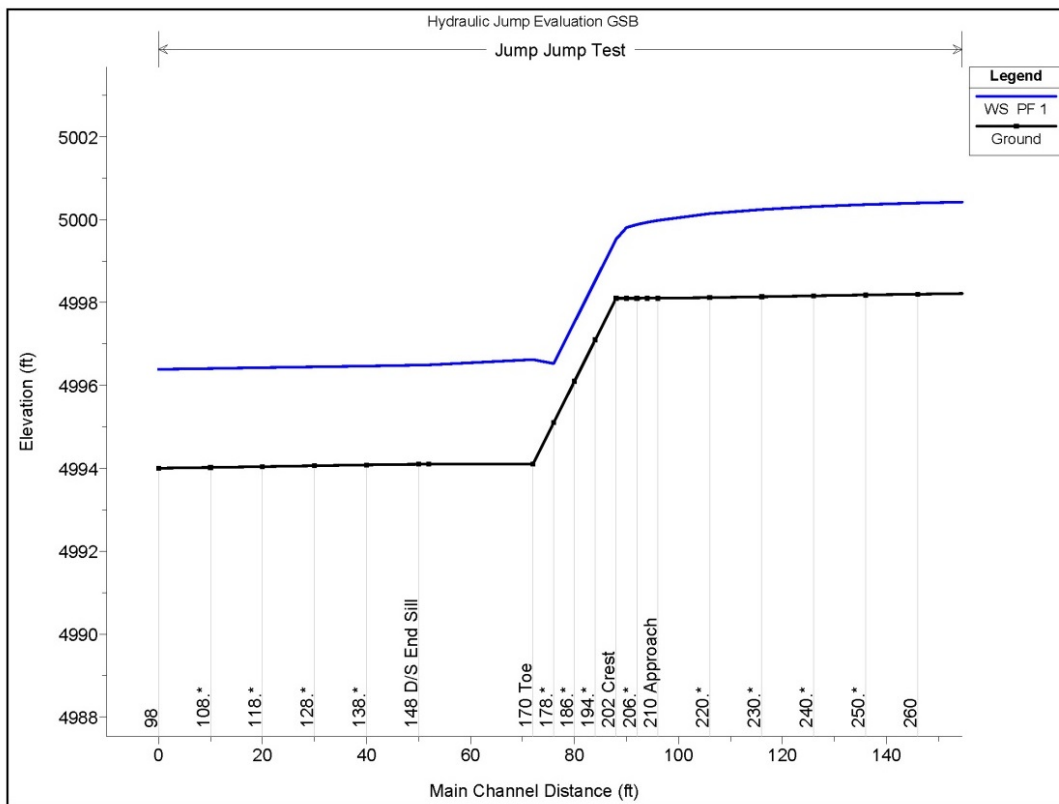
When the parameters of a proposed drop structure do not fit within the criteria of a simplified design (see Section 2.2), or when a designer desires a more thorough analysis of drop structure hydraulics, a detailed hydraulic analysis is conducted. The guidelines presented in this section assume that the designer is using HEC-RAS to assist with the detailed computations necessary for drop structure analysis. It is important to be familiar with the HEC\_RAS variables selected for the computations and the effect these variables have on the results of the analysis. The analysis guidelines discussed in this section are intended to assist the engineer in addressing critical hydraulic design factors.

### 2.3.2 Cross Section Placement

Appropriate placement of cross sections is important when completing a hydraulic analysis of a drop structure using HEC\_RAS. Place cross-sections at the following locations:

- Upstream of Drop (50 feet +/-) where channel is at normal depth
- Drop Approach (5 feet +/- upstream of drop crest)
- Drop Crest
- Toe of Drop
- Upstream and at Drop End Sill
- Downstream of Drop (50 feet +/-) where channel has recovered to normal depth

In addition to the locations above, use the “cross section interpolation” option in HEC\_RAS. At a minimum, add interpolated cross sections (denoted with \* in Figure 9-2) along the drop face. Interpolated cross sections upstream of the drop crest and downstream of the end sill may also be beneficial. Figure 9-2 provides a sample channel profile from HEC\_RAS with cross section locations for reference.



\*Denotes Interpolated Cross Section

**Figure 9-2. Sample HEC\_RAS profile with cross section locations for hydraulic analysis**

### 2.3.3 Mannings's Roughness Coefficient for Drop Structures

Depending on the type of materials and the relative depth, select the appropriate roughness parameters for the HEC-RAS model. Table 9-2 provides roughness parameter recommendations and references for both sculpted concrete and grouted boulder drop structure.

**Table 9-2. Approximate Manning's roughness at design discharge for stepped drop structure**

Stepped sculpted concrete where step heights equal 25% of drop	0.025 <sup>1</sup>
Grouted Boulders	See Figure 9-3

<sup>1</sup> This assumes an approach channel depth of at least 5 feet. Values would be higher at lesser flow depths.

The equations typically used for riprap and provided in the *Open Channels* chapter do not apply to boulders and grouted boulders because of their near uniform size and because the voids may be completely or partially filled with grout. Therefore, the Manning's roughness values for grouted boulders are based on (Chow 1959; Oliver 1967; Anderson et. Al 1973; Henderson 1966; Barnes 1967; Smith and Murray 1975; Stevens et. Al. 1976; Bathurst, Li and Simons 1979; and Stevens 1984). The roughness coefficient varies with the depth of flow relative to the size of the boulders and the depth of grout used to lock them in place.

The following equations may be used to find the recommended Manning's  $n$  as a function of flow depth over height of the boulders,  $y/D$ , as represented by the curves in Figure 9-3:

When the upper one-half (plus or minus 1 inch) of the rock height is ungrouted, the equation for  $n$  is:

$$n_{24''-42''(1/2)} = \frac{0.097(y/D)^{0.16}}{\ln(2.55y/D)} \quad \text{Equation 9-1}$$

When the upper one-third (plus or minus 1 inch) of the rock height is ungrouted, the equation for  $n$  is:

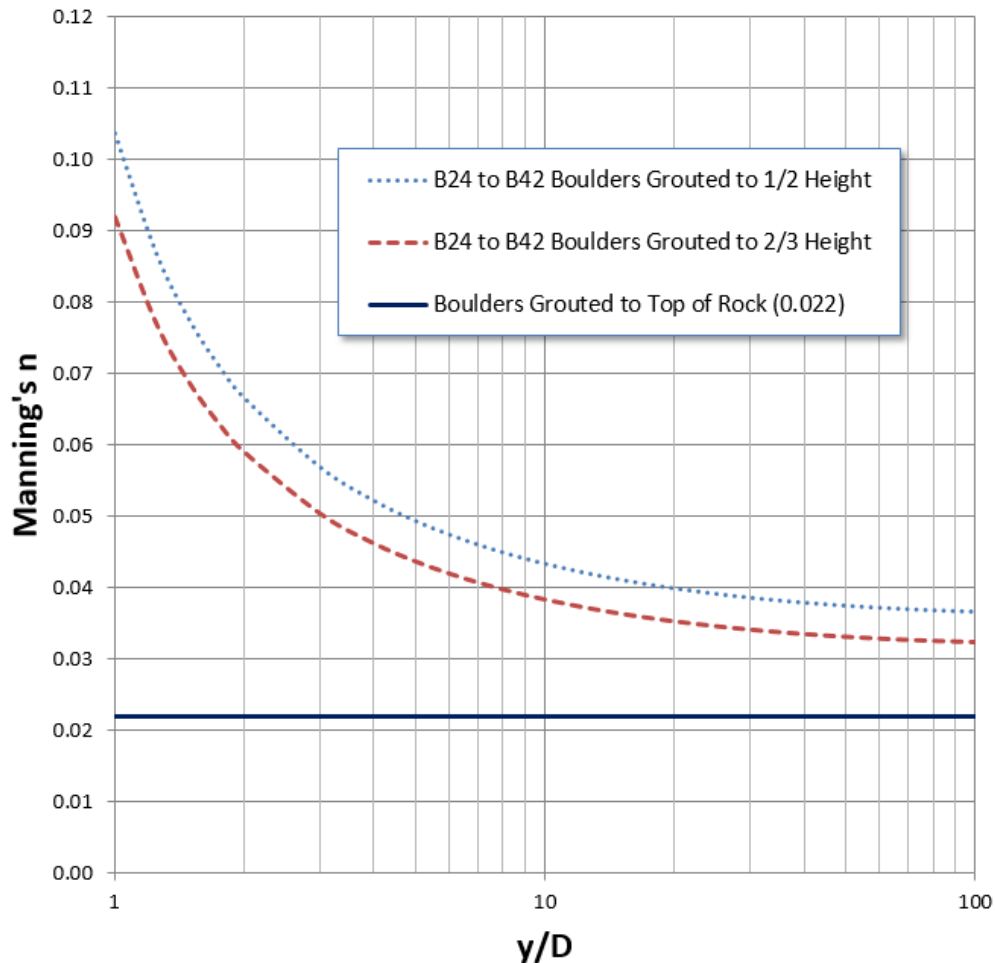
$$n_{24''-42''(2/3)} = \frac{0.086(y/D)^{0.16}}{\ln(2.55y/D)} \quad \text{Equation 9-2}$$

Where:

$y$  = depth of flow above top of rock (feet)

$D$  = diameter of the boulder (feet)

The upper limit for Equation 9-1 is  $n \leq 0.104$  and for Equation 9-2 is  $n \leq 0.092$ . Determine the value for "y" by reviewing the HEC\_RAS cross sections and determining an appropriate representation of the average flow depth over the structure. If the value for  $y/D$  is  $< 1$ , use 1.



**Figure 9-3. Recommended Manning's n for flow over B24 to B42 grouted boulders**

Using a stepped grouted rock placement and grouting only the lower ½ of the rock on the drop face creates a significantly higher Manning's n roughness coefficient and, as a result, greater flow depth and lower velocity, reducing the boulder size needed to have a stable structure. Refer to Section 2.6.3 for discussion on boulder sizing for GSB drop structures.

### 2.3.4 Hydraulic Jump Formation

Once the location and geometry of the drop structure cross sections have been determined, evaluate the HEC-RAS model for the design flow under both subcritical and supercritical flow conditions. To minimize the stilling basin length, use a downstream tailwater depth great enough to force a hydraulic jump to start near the toe of the drop face. This requires that the specific force of the downstream tailwater be greater than the specific force of the supercritical flow at the toe of the drop. The tailwater is modeled by a subcritical water surface (M1 backwater or M2 drawdown curve) profile analysis that starts from a downstream control point and works upstream to the drop structure basin. Model the depth and specific force at the toe of the drop by a supercritical water surface (S2 drawdown curve) profile analysis starting at the crest of the drop and running down the drop face.

Using the output from the subcritical and supercritical HEC-RAS hydraulic models, calculations should be completed to verify that the specific force associated with the downstream tailwater is greater than the specific force of the supercritical flow at the toe of the drop, not only for the design discharge, but for flows corresponding to more frequent events. Specific force can be calculated using equation 9-3 (Chow 1959):

$$F = \frac{Q^2}{gA} + \bar{z}A \quad \text{Equation 9-3}$$

Where:

$F$  = specific force

$Q$  = flow at cross section

$g$  = acceleration of gravity

$\bar{z}$  = distance from the water surface elevation to the centroid of the flow area ( $A$ )

$A$  = area of flow

The required tailwater depth is determined using Equation 9-4 (Chow 1959). This equation applies to rectangular channel sections and should be applied to a rectangular portion of flow within a drop structure. For irregular (non-rectangular) channel shapes, the designer should apply Equation 9-4 using the unit discharge within a rectangular segment of the drop crest. Assuming the low-flow channel is incorporated into the drop crest and this portion of the crest has the largest unit discharge, the rectangular portion would extend over the bottom width of the low-flow channel. See Section 2.3.6 for additional discussion on evaluating the conditions in both the low-flow channel and the overbanks.

$$\frac{y_2}{y_1} = \frac{1}{2} \left( \sqrt{1 + 8F_1^2} - 1 \right) \quad \text{Equation 9-4}$$

Where:

$y_2$  = required depth of tailwater (also called the sequent depth, in feet)

$y_1$  = depth of water at drop toe, feet (taken from cross section at drop toe, supercritical HEC-RAS model)

$F_1$  = Froude Number =  $V_1/(gy_1)^{1/2}$  (based on depth and velocity at drop toe)

Calculate the required tailwater depth ( $y_2$ ) using Equation 9-4. Compare the results of this calculation to the modeled tailwater depth determined in the subcritical HEC-RAS model at the upstream side of the end sill (channel depth plus  $Db$ ). The modeled tailwater depth must be greater than or equal to the calculated required headwater depth for a hydraulic jump to start near the toe of the drop. If the modeled tailwater depth is less than required, the drop structure geometry must be re-evaluated. One option is to increase the depth of the stilling basin, thereby increasing the effective tailwater depth and specific force, and another is to widen the crest of the drop or reduce the depth of the low-flow channel to produce a smaller unit discharge.

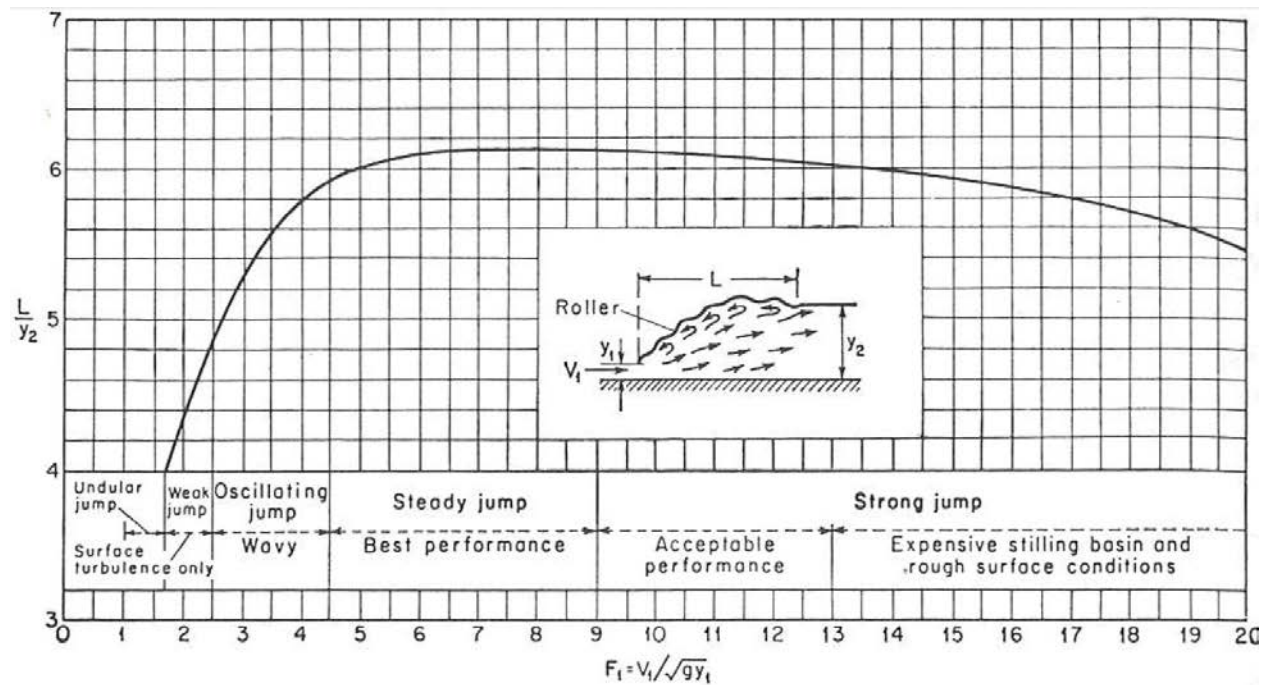
### 2.3.5 Hydraulic Jump Length

After the hydraulic jump has been analyzed using the guidelines provided in Section 2.3.4, the jump length must be calculated. This will aid the designer in determining the appropriate stilling basin length and the need for additional rock lining downstream of the end sill. The following values are required to determine the hydraulic jump length:

$$y_2 = \text{required depth of tailwater (feet)}$$

$$F_1 = \text{Froude Number} = V_1 / (gy_1)^{1/2} \text{ (based on depth and velocity at drop toe)}$$

Use the above values to determine the length of the hydraulic jump (L) in Figure 9-4. Note that this figure is for horizontal channels, which is appropriate for most applications in the UDFCD region. Curves for sloping channels (from 5 to 25%) are in Chow, 1959.



**Figure 9-4. Length in terms of sequent depth of jumps in horizontal channels**  
 (Source: US Bureau of Reclamation, 1955)

UDFCD recommends a hard-lined stilling basin (sculpted concrete, grouted boulders, or concrete grout) that is at least 60% of the hydraulic jump length (L). Extend riprap downstream of the sill and provide protection for at least the balance of the full hydraulic jump length (see Figure 9-5). Determine riprap size using the equations provided in the *Open Channels* chapter for channel lining.

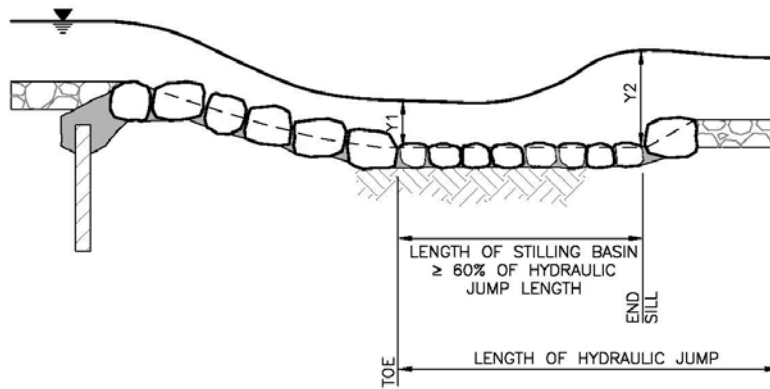


Figure 9-5. Stilling basin profile

### 2.3.6 Evaluation of Low-flow Channel versus Overbanks

Review the HEC-RAS model to evaluate the hydraulic conditions in both the low-flow channel and the overbanks at the crest and 20 to 50 feet upstream of the crest and determine the maximum representative unit discharge (See Section 2.2.3). Check the shear velocity in the overbanks of low-flow drops to determine if protection in this area is appropriate.

Use the “worst case” hydraulic scenario to design the entire drop structure. In most conditions, the low-flow channel will see the greater unit discharge and velocity and therefore represent the “worst case.” HEC-RAS provides output tables to assess the conditions in both the low-flow and overbanks (see Figure 9-6).

Certain site conditions may warrant a separate evaluation for the low-flow channel and overbanks. In some cases, the designer may elect to extend the stilling basin longer in the low-flow channel area than the overbanks; however, in such cases the transition in basin length should be gradual rather than abrupt.

Plan: extrasec Jump Jump Test RS: 202 Profile: PF 1

E.G. Elev (ft)	5001.06	Element	Left OB	Channel	Right OB
Vel Head (ft)	0.65	Wt. n-Val.	0.05	0.05	0.05
W.S. Elev (ft)	5000.41	Reach Len. (ft)	4	4	4
Crit W.S. (ft)	5000.41	Flow Area (sq ft)	69.05	23.09	69.05
E.G. Slope (ft/ft)	0.027778	Area (sq ft)	69.05	23.09	69.05
Q Total (cfs)	1000	Flow (cfs)	400.13	199.74	400.13
Top Width (ft)	118.47	Top Width (ft)	54.23	10	54.23
Vel Total (ft/s)	6.2	Avg. Vel. (ft/s)	5.8	8.65	5.8
Max Chl Dpth (ft)	2.31	Hydr. Depth (ft)	1.27	2.31	1.27
Conv. Total (cfs)	6000	Conv. (cfs)	2400.8	1198.4	2400.8
Length Wtd. (ft)	4	Wetted Per. (ft)	54.56	10	54.56
Min Ch El (ft)	4998.1	Shear (lb/sq ft)	2.19	4	2.19
Alpha	1.09	Stream Power (lb/ft s)	12.72	34.64	12.72
Frctn Loss (ft)	0.1	Cum Volume (acre-ft)	0.03	0.46	0.03
C & E Loss (ft)	0	Cum SA (acres)	0.03	0.2	0.03

Figure 9-6. Sample HEC-RAS output for cross section located at drop crest

### 2.3.7 Evaluate Additional Return Period Flow Rates

Evaluate the design flow and then assess additional return-period flow rates, as appropriate. For all flows, the actual downstream tailwater should be greater than the tailwater required to force a hydraulic jump to start near the toe of the drop structure face. When this condition is met for a range of events a stilling basin length of 60% of the hydraulic jump length should be adequate.

### 2.3.8 Rock Sizing for Drop Approach and Downstream of End Sill

Calculate the appropriate rock size for the drop approach and downstream of the end sill. The hydraulic conditions at the approach include the acceleration effects of the upstream drawdown as the water approaches the drop crest. Turbulence generated from the hydraulic jump will impact the area downstream of the end sill. Determine riprap size using the equations provided in the *Open Channels* chapter for channel lining. Because normal depth conditions do not exist upstream and downstream of the drop structure, refer to the HEC-RAS output and use the energy grade line slope (rather than channel slope) to determine the appropriate riprap size.

Riprap at the approach and downstream of the end sill should be a minimum  $D_{50}$  of 12-inches, or larger as determined using the channel lining equation in the *Open Channels* chapter. Use either void-filled or soil-filled riprap in these areas.

## 2.4 Seepage Control

### 2.4.1 Introduction

Subgrade erosion caused by seepage and structure failures caused by high seepage pressures or inadequate mass are two failure modes of critical concern.

Seepage analyses can range from hand-drawn flow nets to computerized groundwater flow modeling. Use advanced geotechnical field and laboratory testing techniques confirm permeability values where complicated seepage problems are anticipated. Several flow net analysis programs are currently available that are suitable for this purpose. Full description of flow net analysis is beyond the scope of the Urban Storm Drainage Criteria Manual (USDCM). Referred to Cedergren 1967; USBR 1987; and Taylor 1967 for more information and instruction in the use of flow net analysis techniques. See Section 2.4.3 for Lane's Weighted Creep method, a simplified approach.

### 2.4.2 Weep Drains

Install weep drains in all grade control structures greater than 5 feet in net height or as recommended by the geotechnical engineer. Weep drains assist in reducing the uplift pressure on a structure by providing a location for groundwater to escape safely through a filter. For concept, see Figure 9-10. Weep drains should be placed outside of the low-flow path of the structure and spaced to provide adequate relief of subsurface pressures.

### 2.4.3 Lane's Weighted Creep Method

As a minimum level of analysis and as a first order of estimation, Lane's Weighted Creep (Lane's) Method can be used to identify probable seepage problems, evaluate the need for control measures, and estimate rough uplift forces. It is not as definitive as the flow net analyses mentioned above. Lane's method was proposed by E.W. Lane in 1935. This method was removed from the 1987 revision of *Design of Small Dams* (USBR 1987), possibly indicating greater use of flow net and computer modeling

methods or perhaps for other reasons not documented. Although Lane's method is relatively well founded, it is a guideline, and when marginal conditions or complicated geological conditions exist, use the more sophisticated flow-net analysis.

The essential elements of Lane's method are as follows:

1. The weighted-creep distance through a cross section of a structure is the sum of the vertical creep distances,  $L_v$  (along contact surfaces steeper than 45 degrees), plus one-third of the horizontal creep distances,  $L_H$  (along contact surfaces less than 45 degrees).
2. The weighted-creep head ratio is defined as:

$$C_w = \frac{\left(\frac{L_H}{3} + L_v\right)}{H_s} \quad \text{Equation 9-5}$$

Where:

$C_w$  = creep ratio

$H_s$  = differential head between analysis points (ft)

3. Reverse filter drains, weep holes, and pipe drains help to reduce seepage problems, and recommended creep head ratios may be reduced as much as 10% if they are used.
4. In the case where two vertical cutoffs are used, then Equation 9-6 should be used along with Equation 9-2 to check the short path between the bottom of the vertical cutoffs.

$$C_{w2} = \frac{(L_{v-US} + 2L_{H-C} + L_{v-DS})}{H_s} \quad \text{Equation 9-6}$$

Where:

$C_{w2}$  = creep ratio where two vertical cutoffs are used

$L_{v-US}$  = vertical distance on the upstream side of the upstream cutoff (ft)

$L_{v-DS}$  = vertical distance on the downstream side of the downstream cutoff (ft)

$L_{H-C}$  = horizontal distance between the two vertical cutoffs (ft)

5. If there are seepage lengths upstream or downstream of the cutoffs, they should be treated in the numerator of Equation 9-6 similar to Equation 9-5. Seepage is controlled by increasing the total seepage length such that  $C_w$  or  $C_{w2}$  is raised to the value listed in Table 9-3. Test soils during design and again during construction.
6. Estimate the upward pressure in design by assuming that the drop in uplift pressure from headwater to tailwater along the contact line of the drop structure is proportional to the weighted-creep distance.

**Table 9-3. Lane's weighted creep: Recommended minimum ratios**

Material	Ratio
Very fine sand or silt	8.5
Fine sand	7.0
Medium sand	6.0
Coarse sand	5.0
Fine gravel	4.0
Medium gravel	3.0
Coarse gravel including cobbles	3.0
Boulders with some cobbles and gravel	3.0
Soft clay	3.0
Medium clay	2.0
Hard clay	1.8
Very hard clay or hardpan	1.6

#### 2.4.4 Foundation/Seepage Control Systems

As a general rule, groundwater flow cutoffs should not be installed at the downstream ends of drop structures. They can cause greater hydraulic uplift forces than would exist without a downstream cutoff. The design goal is to relieve the hydrostatic pressures along the structure and not to block the groundwater flow and cause higher pressures to build up.

The hydraulic engineer must calculate hydraulic loadings that can occur for a variety of conditions such as dominant low flows, flood flows, design flows and other critical loading scenarios. A geotechnical engineer should combine this information with the on-site soils information to determine foundation requirements. Both engineers should work with a structural engineer to establish final loading diagrams and to determine and size structural components.

The designer needs to be cognizant of field conditions that may affect construction of a drop structure, including site water control and foundation moisture and compaction. A common problem is destabilization of the foundation soils by rapid local dewatering of fine-grained, erosive soils or soils with limited hydraulic conductivity. Since subsurface water control during construction is so critical to the successful installation of a drop structure, the designer needs to develop ways to ensure that the contractor adequately manages subsurface water conditions.

During construction, check design assumptions in the field including the actual subgrade condition with respect to seepage control assumptions be inspected and field verified. Ideally, the engineer who established the design assumptions and calculated the required cutoffs should inspect the cutoff for each drop structure and adjust the cutoff for the actual conditions encountered. For example, if the inspection of a cutoff trench reveals a sandy substrate rather than clay, the designer may choose to extend the cutoff trench, or specify a different cutoff type. Pre-construction soil testing is an advisable precaution to minimize changes and avoid failures.

Proper dewatering in construction will also improve conditions for construction structures. See Fact Sheet SM-08, Temporary Diversion Methods, located in Volume 3 of this manual.

## 2.5 Detailed Force Analysis

Each component of a drop structure has forces acting upon it that the design engineer should consider. While a brief summary of these forces is provided in this section, it is beyond the scope of this manual to provide detailed guidance on the evaluation of these forces. It is the design engineer's responsibility to properly account for potential forces in the drop structure design.

While a detailed force analysis may not be necessary for drop structures developed using the guidelines presented in the simplified design procedures, the designer may want to check forces acting on a drop structure. The critical design factors are seepage cutoff and relief and pressure fluctuations associated with the hydraulic jump that can create upward forces greater than the weight of water and structure over the point of interest.

In addition to seepage uplift pressure, the designer should also evaluate the following forces on a drop structure:

- Shear Stress
- Buoyant Weight of Structure
- Impact, Drag and Hydrodynamic Lift Forces
- Turning Force
- Friction
- Frost Heave
- Dynamic Pressure Fluctuations

See Appendix A for additional discussion regarding drop structure force analysis.

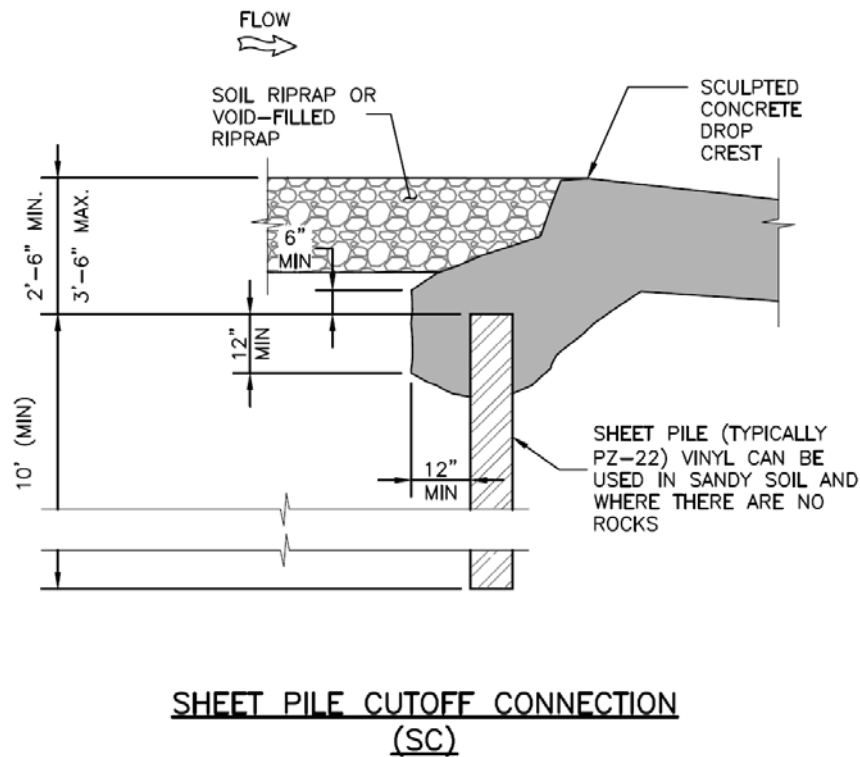
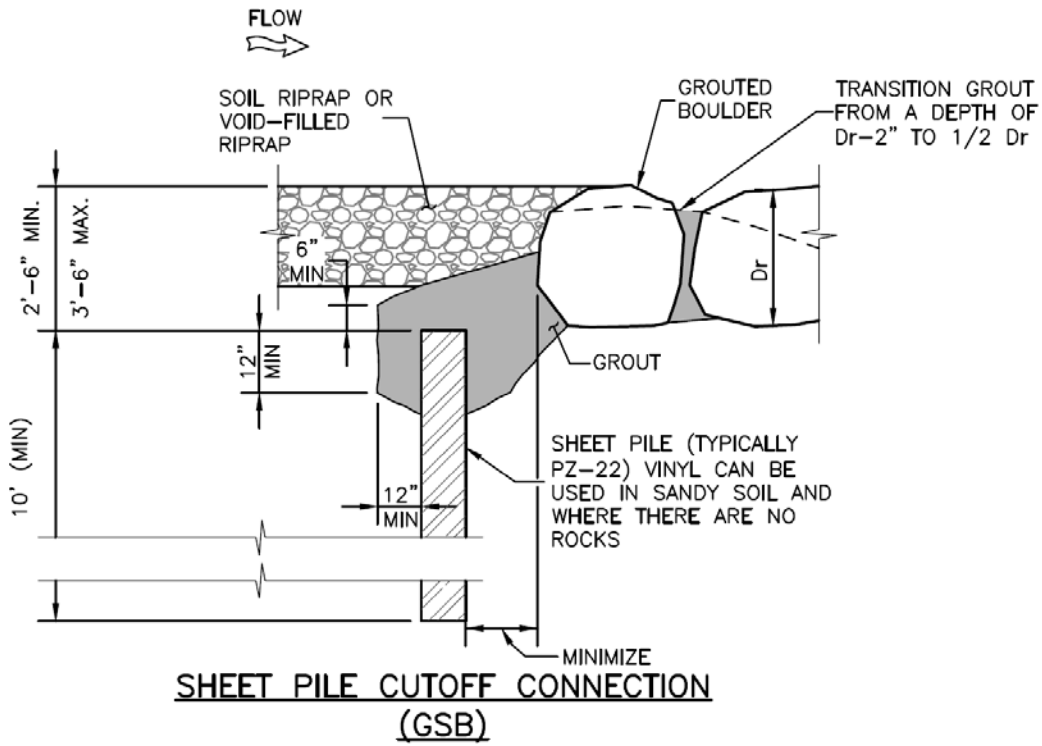
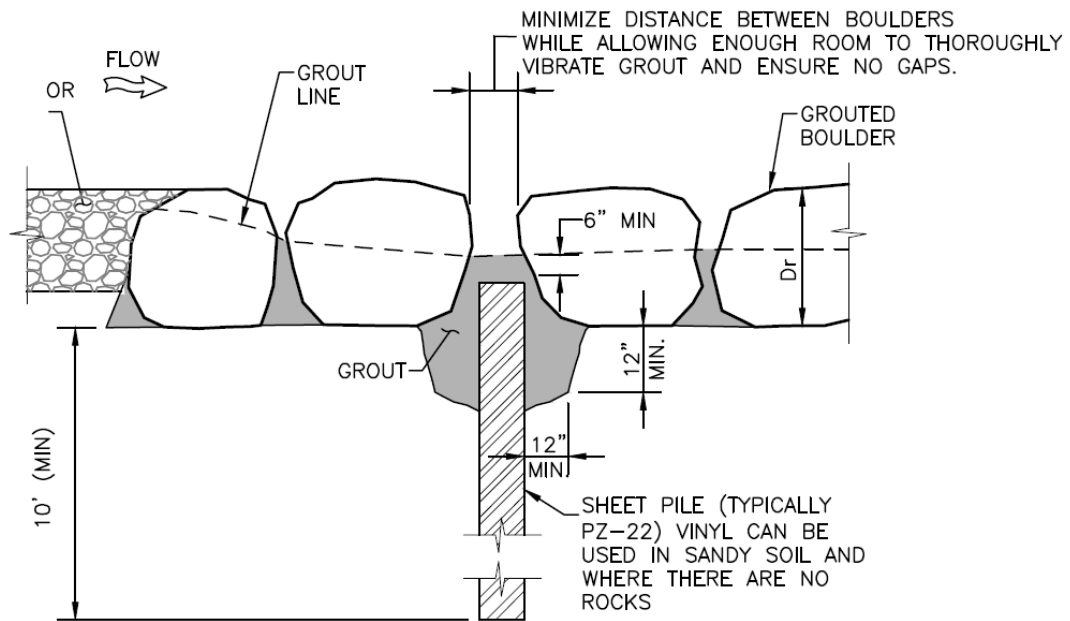


Figure 9-7. Sheet pile cutoff wall upstream of drop structure



**SHEET PILE CONNECTION BETWEEN BOULDERS**

**Figure 9-8. Sheet pile cutoff wall connections between boulders**

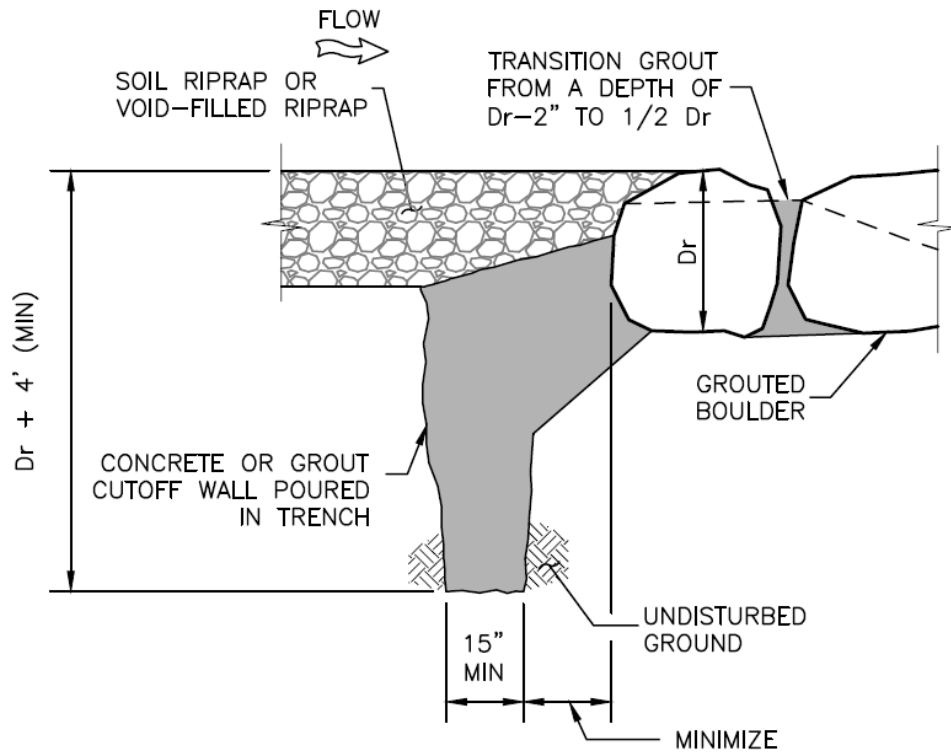
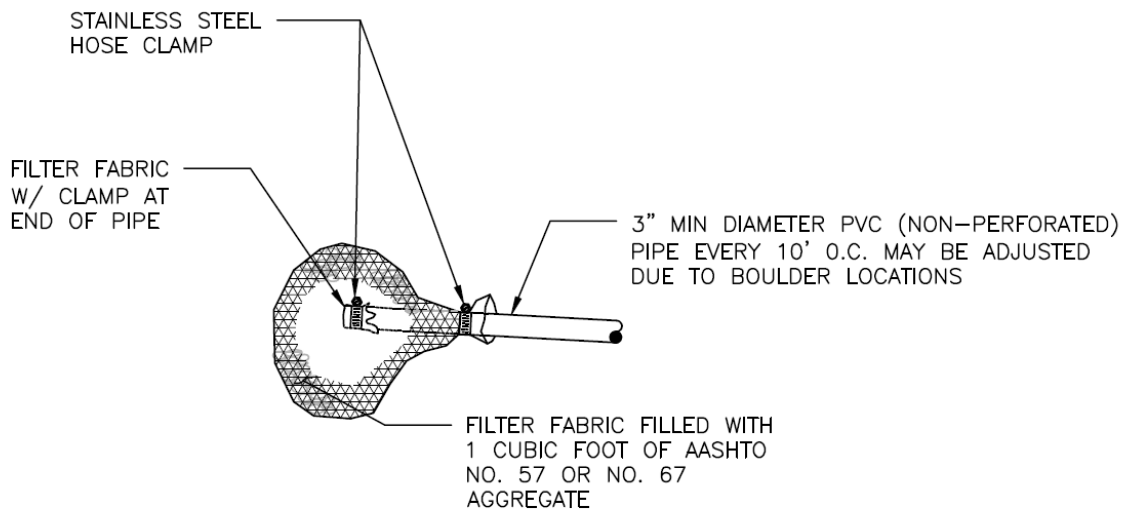
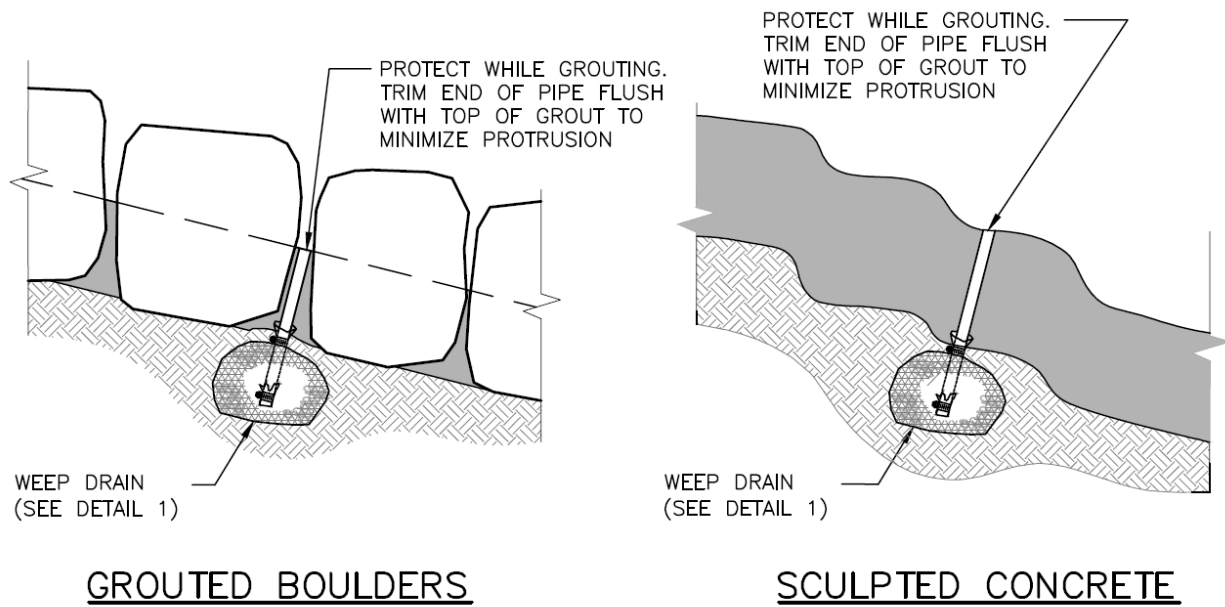


Figure 9-9. Concrete or grout cutoff wall upstream of drop structure



**DETAIL 1**  
**WEEP DRAIN**

NOTE: INSTALL WEEP DRAINS FOR DROPS AND WALLS 5' AND GREATER AT 10' O.C. AT ELEVATIONS AND LOCATIONS SHOWN ON THE DRAWINGS

**Figure 9-10. Weep drains**

## 2.6 Grouted Stepped Boulder Drop Structures

### 2.6.1 Description

Grouted stepped boulder (GSB) drop structures have gained popularity in the UDFCD region due to close proximity to high-quality rock sources, design aesthetics, and successful applications. The quality of rock used and proper grouting procedure are very important to the structural integrity.

To improve appearance, cover the grouted boulders above the low-flow section and on the overbanks with local topsoil and revegetated. This material has potential to wash out but when able to become vegetated, has a more attractive and natural appearance.

### 2.6.2 Structure Complexity

An enlarged plan view of the structure will be necessary for all projects. The amount of detail shown on that plan view will vary depending on the structure complexity, which should be determined early in the design phase.

Sample plans for GSB drop structures are provided in this chapter and are referred to as either “basic” or “complex”. A basic structure generally has more of a linear shape with little variation in the step widths and heights. A complex structure will be non-linear with more variation, which may result in a need for more details and cross sections. It is imperative that adequate detail be provided for a complex structure to be constructed as intended.



**Photograph 9-5.** Example of stepped downstream face for a grouted boulder drop structure. Note dissipation of energy at each step for low flows.

Figures 9-11 through 9-13 illustrate the general configuration of a GSB drop structure. These figures include plan view, profile, and cross sections at key locations along the drop structure. Figure 9-14 provides an example configuration for a complex GSB drop structure, including a plan view and profile. These figures also serve as an example of the recommended level of detail for construction drawings.

### 2.6.3 Design Criteria

Hydraulic analysis and design of GSB drop structures should be according to Section 2.2 (simplified design procedures) or Section 2.3 (detailed hydraulic analysis), as appropriate. In addition, the following guidance also applies to structures constructed of grouted boulders.

#### **Boulder Sizing**

Boulder sizing for GSB drop structures constructed using the simplified method can be determined using Figure 9-1. For drop structures that do not meet the criteria for the simplified design method, the following procedure should be used to determine boulder size.

1. If the vertical distance from the drop toe to the drop crest is less than or equal to six feet, determine the critical velocity for the design flow in both the low-flow channel and the overbanks. This velocity occurs just upstream of the drop crest. For drop structures up to six feet in height, gradually varied flow acceleration is considered negligible. If the vertical distance from the drop toe to the drop crest is greater than six feet, determine the actual velocity at the drop toe using S2 curve drawdown calculations for the design flow in both the low-flow channel and the overbanks. This can be done using either the standard step or the direct step method. If a detailed hydraulic analysis has been completed using HEC-RAS (see Section 2.3), then the actual velocity is provided in the HEC-RAS output and the critical velocity can be taken from the section just upstream of the drop structure.
2. Calculate rock-sizing parameter,  $R_p$  (dimensionless), for both segments of the cross section (overbanks and in the low-flow channel):

$$R_p = \frac{VS^{0.17}}{(S_s - 1)^{0.66}} \quad \text{Equation 9-7}$$

Where:

$V$  = critical velocity,  $V_c$  (for drop structure heights up to six feet) or drawdown velocity at the toe of the drop (for drop height exceeding six feet)

$S$  = slope along the face of the drop (ft/ft)

$S_s$  = specific gravity of the rock (Assume 2.55 unless the quarry certifies a higher value.)

Note that for drop heights exceeding six feet, Equation 9-7 becomes iterative, since Manning's roughness coefficient is a function of the boulder size, from Equation 9-1 or 9-2.

3. Select minimum boulder sizes for the cross-section segments within and outside the low-flow channel cross-section from Table 9-4. If the boulder sizes for the low-flow channel and the overbank segments differ, UDFCD recommends using only the larger sized boulders throughout the entire structure. Mistakes during construction are more common when specifying multiple rock sizes within the same structure.

**Table 9-4. Boulder sizes for various rock sizing parameters**

Rock Sizing Parameter, $R_p$	Grouted Boulders <sup>1</sup>
	Boulder Classification <sup>2</sup>
Less than 5.00	B24
5.00 to 5.59	B24
5.60 to 6.99	B36
7.00 to 8.00	B48

<sup>1</sup> Grouted to no less than  $\frac{1}{3}$  the height (+1"/- 0"), no more than  $\frac{1}{2}$  (+0"/- 1") of boulder height.

<sup>2</sup> See *Open Channels* chapter.

### Grout

Grout all boulders to a depth of one-half their height through the approach, sloping face, and basin areas. Grout should extend near full depth of the rock at the upstream crest and around the perimeter of the structure where it is adjoining the earth in order to provide stability of the approach channel. See Figure 9-15 for grout placement and material specifications.

### Edge Wall

Construct a wall that extends roughly 3 feet below the top surface of the structure around the entire perimeter of the GSB drop structure. See Figure 9-22 for an edge wall detail. An edge wall is especially necessary for structures designed to convey less than the 100-year flow but is also beneficial for structures that do span the 100-year flow. In addition, use buried riprap around the perimeter of the structure when this is the case. The transition between soil and the grouted boulders can become a problem if not properly addressed during design and construction. Ensure compaction around the perimeter of the structure and grade this area higher than the structure to promote sheet flow onto the structure.

### Additional Design Guidance

Grouted boulders must cover the crest and cutoff and extend downstream through the stilling basin (when applicable), or through the embedded toe of the drop structure when a stilling basin is not included. Place boulders to create a stepped appearance, which helps to increase roughness. Additional information regarding riprap and boulders is in the *Open Channels* chapter.

## 2.6.4 Construction Guidance

Grouted boulder drop structures require significant construction oversight. During placement of the rock and construction in general, disturb the subgrade as little as possible to reduce the potential for piping under the structure. Good subgrade preparation, careful rock placement, and removal of loose materials will reduce potential piping. Do not place granular bedding (or subgrade fill using granular materials) between subgrade and the boulders. This can cause piping. Place boulders directly on undisturbed subgrade where possible. Where the design requires over excavation and/or fill or where wet or poor subgrade exists onsite, ensure proper density and compaction. See Division 31 specifications available at [www.udfcd.org](http://www.udfcd.org). When fill is required, it is best to fill and compact to a set elevation (or sloped surface)

and then “carve” the surface as necessary to place boulders. See figure 9-15 for a placement detail.

Proper grout placement provides overall mass sufficient to offset uplift and reduces piping under the structure. The greatest risk lies with a “sugar-coated” grout job, where the grout does not penetrate the voids fully between the rock and the subgrade and leaves voids below the grout that act as a direct piping route for water, guaranteeing early failure. Ensure grout thickness set at one-half the boulder height, but no more than two-thirds the boulder height (except at the crest and around the perimeter of the structure where the grout should be near grade). Limiting grout thickness also improves the overall appearance of the grouted boulder structure.

Problems with rock density, durability and hardness are of concern and can vary widely for different locations. Inspect the rock at regular intervals to meet minimum physical dimensions, strengths, durability and weights as defined in the specifications.

As stated earlier, it is important to compact the soil around the perimeter of the structure and leave it slightly higher than the structure to promote sheet flow onto the structure. If the soil settles, surface erosion along the edge of the concrete and ultimately structure piping may occur.

Grout used for GSB drop structures shall receive cold or hot weather protection in accordance with the UDFCD construction specifications (see [www.udfcd.org](http://www.udfcd.org)).

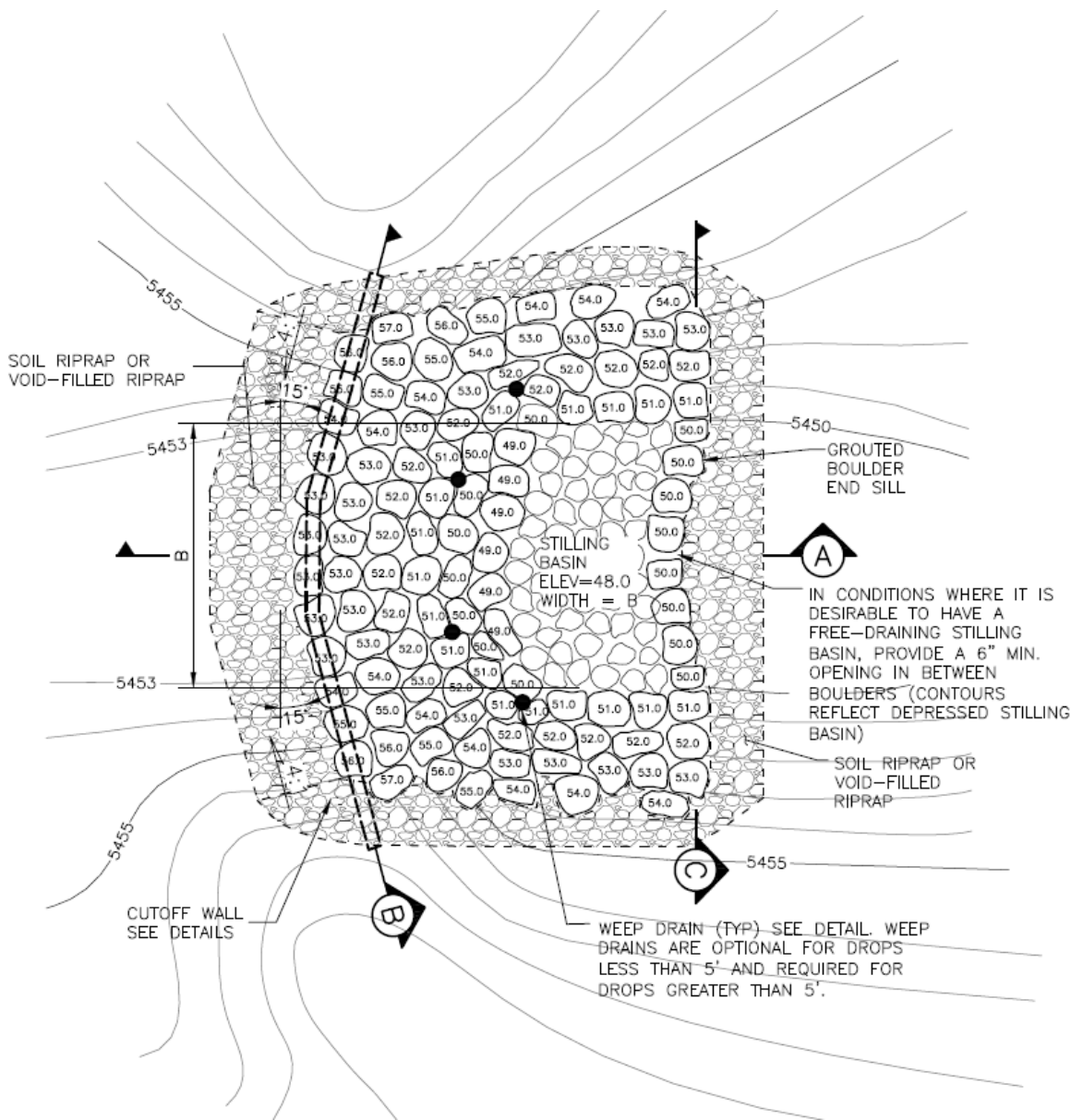


Figure 9-11. Example plan view of basic grouted stepped boulder drop structure

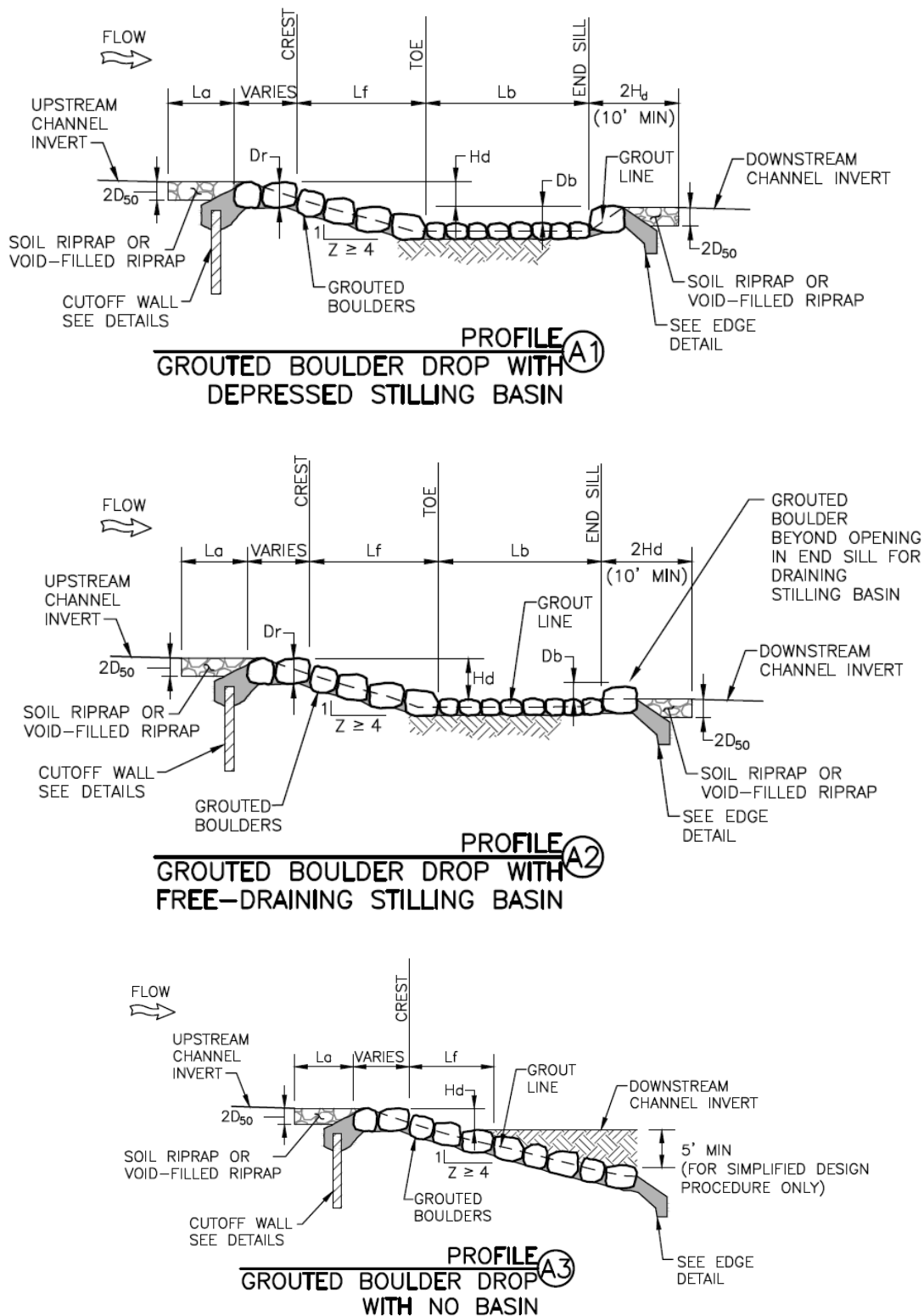


Figure 9-12. Cross sections of basic grouted stepped boulder drop structure

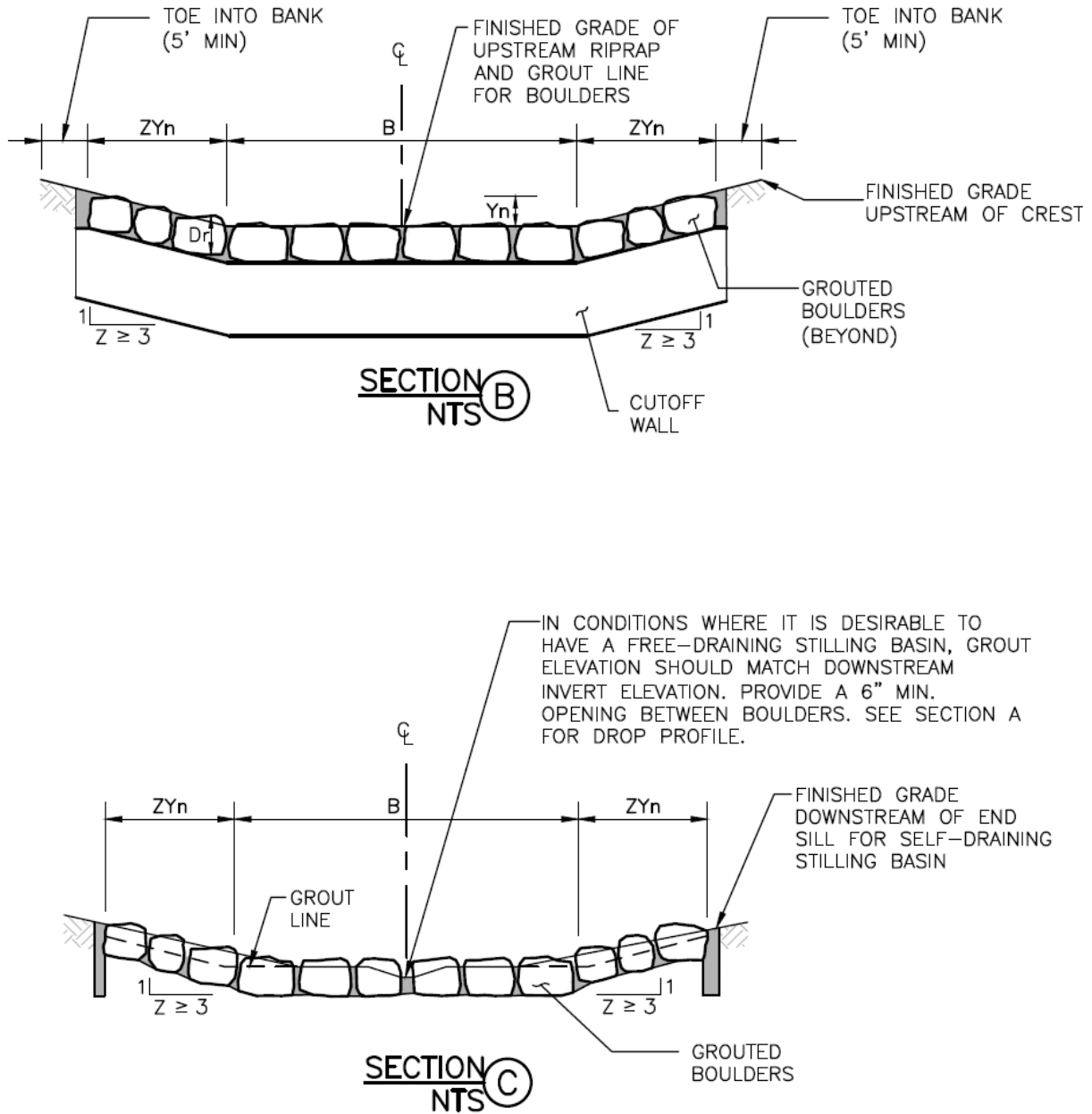


Figure 9-13. Cross sections of basic grouted stepped boulder drop structure

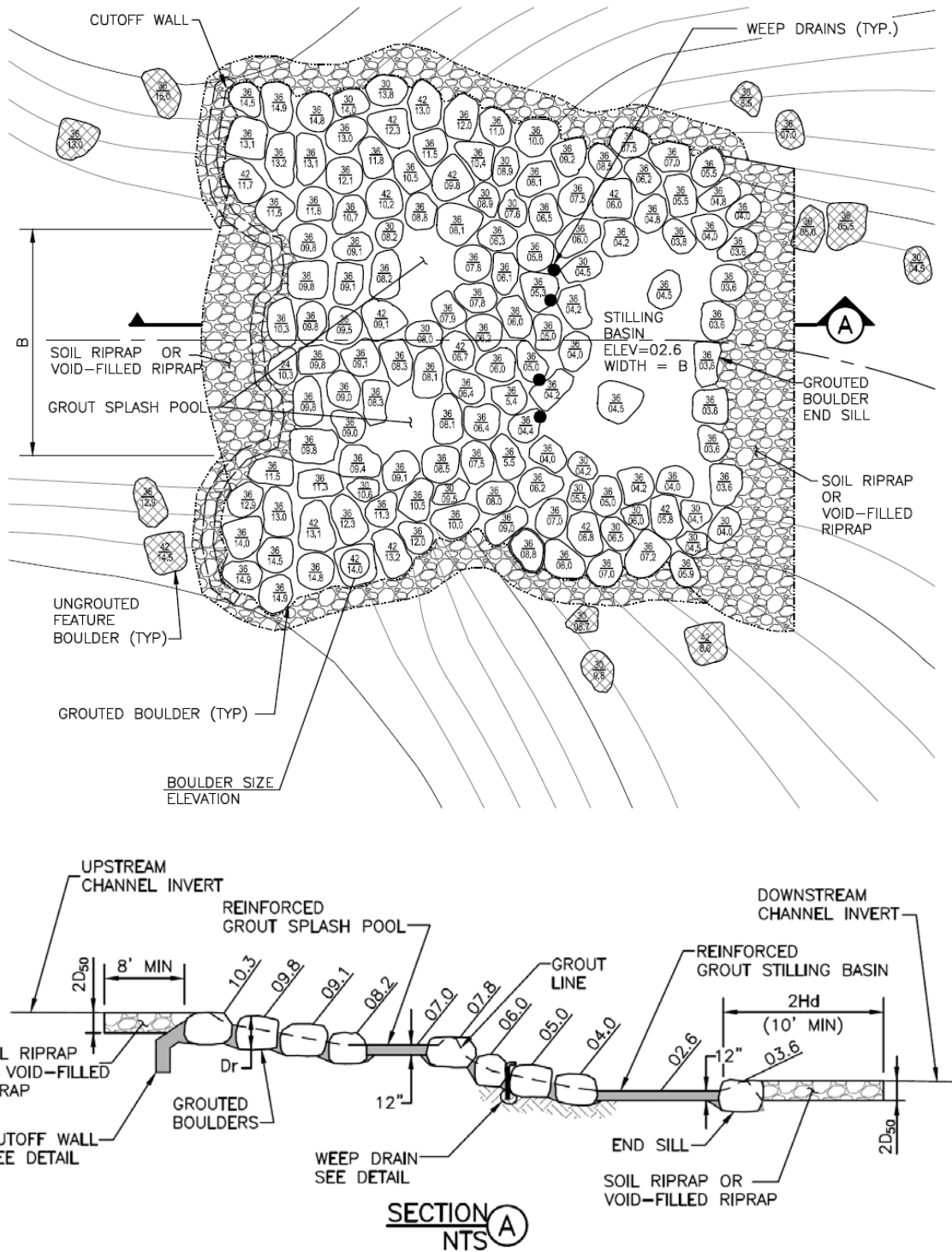
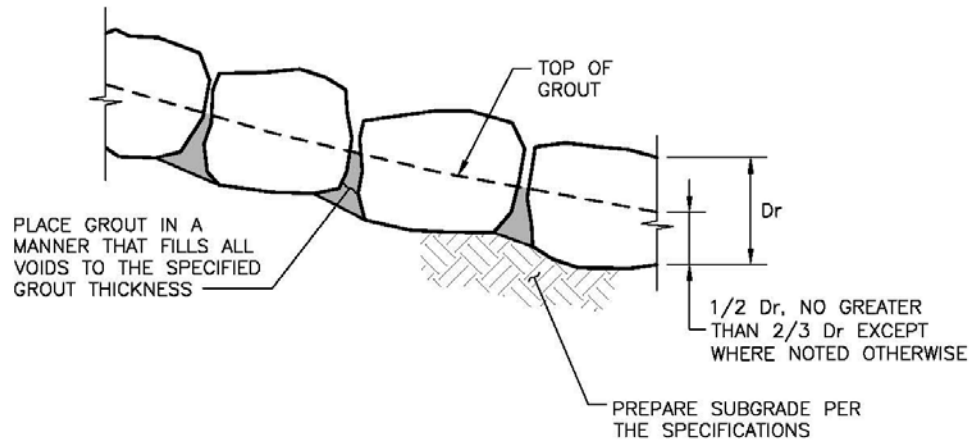


Figure 9-14. Example of complex grouted stepped boulder drop structure

**BOULDER PLACEMENT NOTES:**

1. PLACE BOULDERS WITH THE REQUIRED BOULDER HEIGHT VERTICAL. PLACE BOULDERS AS TIGHTLY TOGETHER AS POSSIBLE (WITHOUT TOUCHING) WHILE PROVIDING ENOUGH ROOM BETWEEN THEM TO THOROUGHLY VIBRATE THE GROUT AND TO ENSURE NO GAPS IN THE GROUT. THE SMALL DIMENSION OF A 2X4 CAN BE USED AS A GUIDE TO CHECK MINIMUM SPACING.
2. BEFORE GROUTING, CLEAN ALL DIRT AND MATERIAL FROM ROCK THAT COULD PREVENT THE GROUT FROM BINDING TO THE ROCK. KEEP BOULDERS FROM TOUCHING. AVOID SLIDING BOULDERS AGAINST SUBGRADE TO PROPERLY POSITION.

**MATERIAL SPECIFICATIONS:**

1. ALL GROUT SHALL HAVE A MINIMUM 28-DAY COMPRESSIVE STRENGTH EQUAL TO 3200 PSI.
2. ONE CUBIC YARD OF GROUT SHALL HAVE A MINIMUM OF SIX (6) SACKS OF TYPE II PORTLAND CEMENT.
3. A MAXIMUM OF 25% TYPE F FLY ASH MAY BE SUBSTITUTED FOR THE PORTLAND CEMENT.
4. THE AGGREGATE SHALL BE COMPRISED OF 70% NATURAL SAND (FINES) AND 30%  $\frac{3}{8}$ -INCH ROCK (COARSE).
5. THE GROUT SLUMP SHALL BE BETWEEN 4-INCHES TO 6-INCHES.
6. AIR ENTRAINMENT SHALL BE BETWEEN 5.5% AND 7.5%.
7. TO CONTROL SHRINKAGE AND CRACKING, 1.5 POUNDS OF FIBERMESH, OR EQUIVALENT, SHALL BE USED PER CUBIC YARD OF GROUT.
8. COLOR ADDITIVE IN REQUIRED AMOUNTS SHALL BE USED WHEN SO SPECIFIED BY CONTRACT.

**GROUT PLACEMENT SPECIFICATIONS:**

1. SPECIAL PROCEDURES SHALL BE REQUIRED FOR GROUT PLACEMENT WHEN THE AIR TEMPERATURES ARE LESS THAN 40°F OR GREATER THAN 90°F. CONTRACTOR SHALL OBTAIN PRIOR APPROVAL FROM THE DESIGN ENGINEER OF THE PROCEDURES TO BE USED FOR PROTECTING THE GROUT.
2. GROUT SHALL BE DELIVERED BY MEANS OF A LOW PRESSURE (LESS THAN 10 PSI) GROUT PUMP USING A 2-INCH DIAMETER (MAXIMUM) NOZZLE.
3. FULL DEPTH PENETRATION OF THE GROUT INTO THE BOULDER VOIDS SHALL BE ACHIEVED BY INJECTING GROUT STARTING WITH THE NOZZLE NEAR THE BOTTOM AND RAISING IT AS THE GROUT FILLS, WHILE VIBRATING GROUT INTO PLACE USING A PENCIL VIBRATOR.
4. ALL GROUT BETWEEN BOULDERS SHALL BE TREATED WITH A BROOM FINISH.
5. AFTER GROUT PLACEMENT, EXPOSED BOULDER FACES SHALL BE CLEANED AND FREE OF GROUT.
6. ALL FINISHED GROUT SURFACES SHALL BE SPRAYED WITH A CLEAR LIQUID MEMBRANE CURING COMPOUND AS SPECIFIED IN ASTM C309.

**Figure 9-15. Grouted boulder placement detail**

## 2.7 Sculpted Concrete Drop Structure

Due to increased construction complexity associated with large vertical drops the scope of this section is limited to sculpted concrete drops six feet or less.

### 2.7.1 Description

Concrete faux rock is simply concrete that is sculpted, carved, textured, and colored to emulate real rock. In the past, sculpted concrete has been successfully used for retaining wall type structures and stream grade control structures. It can be an aesthetic alternative to grouted boulders in locations where natural sedimentary rock might be expected.

Geology in the UDFCD region east of the foothills primarily consists of sedimentary rock, of which there are five common types including sandstone, shale, conglomerate, limestone, and claystone. Claystone can be found in eroded streams where less dense soils have been washed away. Claystone is similar to sandstone; however, it is composed of finer particles. These layers of sedimentary rock become exposed due to uplift and erosion.

When considering the design for a new sculpted concrete structure, existing exposed sedimentary rock in the vicinity of the project should be used for guidance. Section 2.7.4 provides additional guidance for determining the appropriate finish for sculpted concrete.

### 2.7.2 Structure Complexity

Early in the design, determine what the expectations are regarding the appearance of the structure. An enlarged plan view of the structure will be necessary for all projects. The amount of detail shown on that plan view will vary depending on the complexity of the design.

Note that an overly complex design does not always result in a more aesthetically pleasing structure. Many quality structures have been constructed using very basic design plans and details. Simplifying the design can reduce confusion and misinterpretation during construction, and also matches the skill level of a greater number of potential bidding contractors.

For the purpose of presenting criteria for sculpted concrete drop structures, this manual refers to sculpted concrete structures as either “basic” or “complex”. Structure complexity is generally tied to the following three items.



**Photograph 9-6.** Exposed sedimentary rock.



**Photograph 9-7.** An eroded channel with exposed claystone layers.

1. **Overall structure footprint:** Non-linear shaped structures with varied edge delineations can be more attractive but require more detailing.
2. **Structure step widths and height:** Varied step widths and heights can improve the appearance of a structure but also adds construction complexity. Step widths can easily be delineated using boundary lines. Varying step heights requires finish grade point elevations to be added to the plan. The quantity of point elevations largely depends on the amount of desired elevation change.
3. **Sloped steps/flat steps:** Flat steps can be constructed based on a single contour or point elevation. If the surface is sloped, slope arrows and a series of point elevations to identify portions of the sloped top surface are beneficial.

If the design includes any of the three items discussed above (non-linear shape, varied step widths, or sloped steps), consider the proposed structure to be complex and prepare a more detailed plan view of the structure. Figures 9-19 and 9-20 present an example of such a plan. Note the additional additional finished grade point elevations and slope arrows compared to Figures 9-16 through 9-18, which provide details for a basic structure. Also included with the complex structure plan is a legend and notes with additional information regarding vegetation beds within the structure and surface treatment. This manual provides further discussion regarding these items later in the chapter, but it is important to note that these elements can also be incorporated into a simple structure without adding complexity. None of the figures in this section are intended as typical details but are provided as an example of the level of detail recommended for this type of design.

### 2.7.3 Design Criteria

Hydraulic analysis and design of SC drop structures should be according to Section 2.2 (simplified design guidance) or Section 2.3 (detailed hydraulic analysis), as appropriate. The following also apply to structures constructed of sculpted concrete.



**Photograph 9-8.** The first sculpted concrete structure in the UDFCD region was along Grange Hall Creek in Northglenn, Colorado. The shape and color was chosen to blend into the existing landscape which consisted of native grasslands.



**Photograph 9-9.** A sculpted concrete drop structure along Marcy Gulch in Highlands Ranch, CO represents a basic structure design.

### Reinforcing Steel

Steel reinforcement is recommended in order to control temperature and shrinkage cracks. It is the responsibility of the designer to verify all structural components of SC drop structures during the design phase. Figure 9-21 provides guidance for rebar placement for SC structures with a flat subgrade and on an undulated subgrade. Larger walled sections within a given structure may require additional evaluation and design.

### Edge Wall

Provide an edge wall that extends roughly 3 feet below the top surface of the structure around the entire perimeter of the SC drop structure. See Figure 9-22 for an edge wall detail. An edge wall is especially important for structures designed to convey less than the 100-year flow but is also beneficial for structures that do span the 100-year flow. The transition between soil and the sculpted concrete can become a problem if not properly addressed during design and construction. During construction ensure compaction of the soil around the perimeter of the structure and grade the area to sheet flow onto the structure. If the soil settles, surface erosion along the edge of the concrete and ultimately structure piping may occur. In addition to the edge wall, install buried soil riprap around the perimeter of the structure when the drop structure does not span the 100-year floodplain. This reduces potential erosion.



**Photograph 9-10.** This drop structure located along Oak Hills Tributary represents a complex design example.

### Concrete Thickness

The concrete should be a minimum of 10 inches thick. As with the steel reinforcement, it is the design engineer's responsibility to complete a structural analysis to determine adequate concrete thickness for structure stability. It is preferred that the subgrade be excavated to closely mirror the finished structure surface, which will allow for the placement of concrete with a consistent thickness. In isolated locations, it may be necessary to thicken the concrete to meet design grades. Ideally, the thickened areas should not exceed 2 feet. Avoid multiple pours of separate layers of concrete over the majority of the structure.

### Concrete versus Shotcrete

Either concrete mix or shotcrete mix are suitable for construction of sculpted concrete drop structures, however designers should be aware that there are advantages and disadvantages for each (See Table 9-5).

**Table 9-5. Comparison of concrete and shotcrete**

	<b>Concrete</b>	<b>Shotcrete</b>
	<ul style="list-style-type: none"> <li>▪ Handling and placement can be performed by a large number of general contractors.</li> <li>▪ Can be rapidly placed with the use of a concrete pump truck, roughly twice as fast as shotcrete. Construction of very large structures as a single pour in 1 day is possible.</li> </ul>	<ul style="list-style-type: none"> <li>▪ Generally has greater compressive strength and is more impervious than concrete.</li> <li>▪ Can be placed in a uniform and consistent manner. Vibrating the shotcrete is not required.</li> <li>▪ Can be placed to create vertical faces and overhangs.</li> </ul>
		<ul style="list-style-type: none"> <li>▪ Shotcrete placement is considered specialty type work and is performed by a limited number of contractors.</li> <li>▪ Shotcrete placement is slow in comparison to concrete placement.</li> <li>▪ Shotcrete structures may be more expensive than concrete.</li> </ul>

### 2.7.4 Decorative Elements (Finishing)

Sculpted concrete finishing refers to modifications intended for visual enhancement. The contractor plays an important role in the finishing process and making the structure look attractive. When contractor selection is limited (e.g., the project is open bid), designers must provide adequate finishing guidance and recommendations on the construction plans.

Finishing is an all-encompassing word that can include:

- Troweling, sculpting, and carving
- Stamping
- Top dressing with sand, gravel, cobbles, or other materials
- Vegetation seams, pockets, or beds
- Coloring/Staining

Depending on the design objectives, a project may include a couple or all of these techniques. This section provides an overview and photograph illustrations of the techniques listed above.

#### Examples in Nature

An abundance of natural formations exist throughout the UDFCD region. Rock formations can vary significantly even if separated by only a short distance. Differences in color, surface roughness, bed angles or strata line angles, and vegetation are apparent. A photographic log of different formations can be a valuable resource when designing, constructing, and finishing sculpted concrete structures. Photographs 9-11, 9-12, and 9-13 show three different rock formations found in the UDFCD region.

#### Troweling, Sculpting, and Carving

Troweling, sculpting, and carving are all terms for the same general action. The contractor typically uses a concrete trowel, float, or other tool to shape the concrete and then carve lines, crevices, or cracks that emulate natural rock features. This requires a contractor with sculpted concrete experience and skill.



**Photo 9-11.** Rock formation with horizontal weathering and surface erosion. Random pockets of vegetation create significant interest. Overall color is gray-white with lichen and other organic surface growth.



**Photo 9-12.** Generally horizontal layered rock formation. Surface texture varies with small pockets of vegetation. Overall color is brown with dark staining in the cracks. Close up view reveals significant granular material bedded into the surface.

Some of the difficulties that may arise during this process include the following:

- Typically, several concrete finishers will work on the same structure producing several different styles of finish treatment within the same structure. Finishers should work together using the same general techniques and producing similar and uniform results.
- Proper sense of scale. Finishers perform the work from an arm's reach. At this close range, the finisher may over-carve the material giving an appearance of a busy and unnatural looking structure when viewed from a distance.
- Style selection. There are many different styles of sculpting and carving. The owner, engineer, and finishers may all have a different vision.

Photographs can be helpful in developing consensus between owner, engineer and contractor. Be as specific as possible with the contractor regarding all of the structure attributes when reviewing photographs. It may be preferred to replicate some characteristics in the photographs and leave out some of the others. Construction of a test panel of sculpted concrete before performing the final structures can also be beneficial. A test panel that is approximately 10 feet by 10 feet is typically adequate in order to practice overall form as well as some of the detailing. If the first panel does not achieve the objectives, construct a second. This is a better alternative to practicing and developing techniques on the structures.

For proper sense of scale, periodically take time to step away from the structure and look at it from a more typical viewing distance. This will allow the finishers to see the structure as a whole.



**Photo 9-13.** Severely uplifted rock formation with layers standing nearly vertical. Surface texture varies within the layers but is mostly smooth. Vegetation appears to grow out of the seams, not necessarily from pockets. Overall color is a light chalky tan.



**Photograph 9-14.** Subtle carving and shaping can often produce the desired results. Notice the single horizontal carving that runs through just one of the steps and is extended into the crest of the structure. Horizontal carvings on all of the steps would be excessive and distract from the overall aesthetics.

### Stamping

Stamping adds surface texture and requires less skill compared to sculpting and carving. Stamping is most often performed using texture mats or skins, which are rubber molds made from real rock surfaces. When pressing the texture mats into wet concrete, the concrete takes the textured surface of the mat. Texture mats are available with a variety of texture styles and relief. Use a liquid or powder release agent to keep the concrete from sticking to the mats. While texture mats are specifically for texturing concrete, a finisher could use an unlimited amount of other materials to create unique or desired finishes.

### Top Dressing with Sand, Gravel, Cobbles or Other Materials

Top dressing a structure with sand, gravel, or cobbles adds texture to the surface of sculpted concrete. While some natural rock formations have a very smooth surface finish, many contain grains of sand and pebbles cemented together. This is typical of the sandstone and conglomerate types of sedimentary rock common in the UDFCD region. It is important to press the material into the sculpted concrete shortly after carving and before the concrete sets. Additionally, the material should be washed clean and free of debris to promote bonding to the concrete. The majority of the material will remain in place over time, but with freeze-thaw, some of it will dislodge. Wetting the material immediately before placement can help reduce the percentage of material that dislodges over time.



**Photograph 9-15.** Texturing a sculpted concrete drop with a rubber skin.



**Photograph 9-16.** Completed sculpted concrete drop structure with loose sand, gravel and cobble embedded into the surface.



**Photograph 9-17.** Small vegetation pockets can be formed using PVC, lumber, or other items. Removed these items shortly before or after the concrete cures. If done after the concrete cures, coat the items with a lubricant to facilitate removal.

### Vegetation Seams, Pockets or Beds

A characteristic of natural rock formations is that grasses, shrubs, and trees can be found living in cracks within the rock. Pairing rock and vegetation helps make the structure appear natural. However, it can be difficult to establish vegetation within a concrete structure. Depending on the stream, dryland vegetation beds and seams should stay above certain minimum flood elevations as they won't tolerate frequent flooding. If placed too low and vegetation does not become established, this leaves a vulnerable area in the structure for piping. A slightly thickened edge of sculpted concrete around the seam or bed is typically adequate. In some cases where flow overtopping is a more significant concern, toewalls around the perimeter of the bed or seam may be necessary along with filter material in the bottom of the bed to guard against piping. Filter material should not be installed along the entire structure, but rather at the specific vegetation bed or seam to reduce the likelihood of piping under the structure, especially at the crest. Geotextile can be used for this purpose or a graded filter system could be constructed.

Plants do not necessarily need a large bed to be sustainable. Consult with an ecologist or other qualified specialist for both proper plant selection and bed construction. For example, a plant species that thrives on the north facing side of a sculpted concrete structure may not be able to live on the south facing side of the same structure where sunlight and heat are more intense. Consider the daily amount of sunlight anticipated, reflective and absorptive heat of the sculpted concrete, and water requirements.

The incorporation of wetland vegetation planting pockets should also be considered and have a higher success rate as conditions for wetland vegetation are favorable within a depressed concrete lined portion of the structure as long as the stream base flow is routed through the basin. These planting pockets should be located outside of the primary energy dissipation area of the structure. This will allow the plants to develop a healthy root structure and hold the plants in place during large flows.



**Photograph 9-18.** The surface of the sculpted concrete can be depressed to capture and direct rainwater to the vegetation.



**Photograph 9-19.** Grass growth in a vegetation pocket shortly after seeding.



**Photograph 9-20.** During the structure subgrade preparation, vegetation beds and pockets were delineated and soil was removed. After the sculpted concrete placement was complete, topsoil was placed in the beds and seeding and planting was performed.

Another method to add color to sculpted concrete is to apply a stain to the finished and cured concrete surface. There are several products available specifically made for concrete. Another acceptable method is to add water to exterior acrylic latex paint until it has the consistency of a stain. This allows for a wide range of available colors. Stains are typically applied by hand-held bottle sprayers, mechanical sprayers, and sponges.

If a test panel has already been constructed, use this panel to practice to develop the desired color scheme. The process of staining includes layering multiple shades of color. Typically light colored stains are applied first followed by darker accent shades. Applying a light coat of watered down black stain as the final coat will create a weathered or aged surface appearance. As with any finishing technique, the experience level of the finisher plays a key role in the outcome.

### 2.7.5 Construction Guidance

For sculpted concrete drop structures, concrete is often placed in a few hours. It is therefore very important to plan the overall appearance of the structure well in advance of concrete placement. Coordinating details with the contractor should occur during subgrade preparation and tying of steel reinforcement. Construction guidance is provided below.

- Subgrade Preparation.** The structure subgrade should be adequately dewatered prior to the commencement of excavation or fill. All fill material should be placed on a minimum 12-inch depth of stripped, scarified, moisture conditioned, and compacted subgrade. During excavation, it is recommended that the contractor cover the exposed subgrade with blanket to avoid excessive drying or erosion. If excessive drying does occur, surface wetting of the soil should be performed.



**Photograph 9-24.** Stained concrete in foreground with natural rock in the background.



**Photograph 9-25.** An example of a “skim coat” applied to the prepared subgrade.

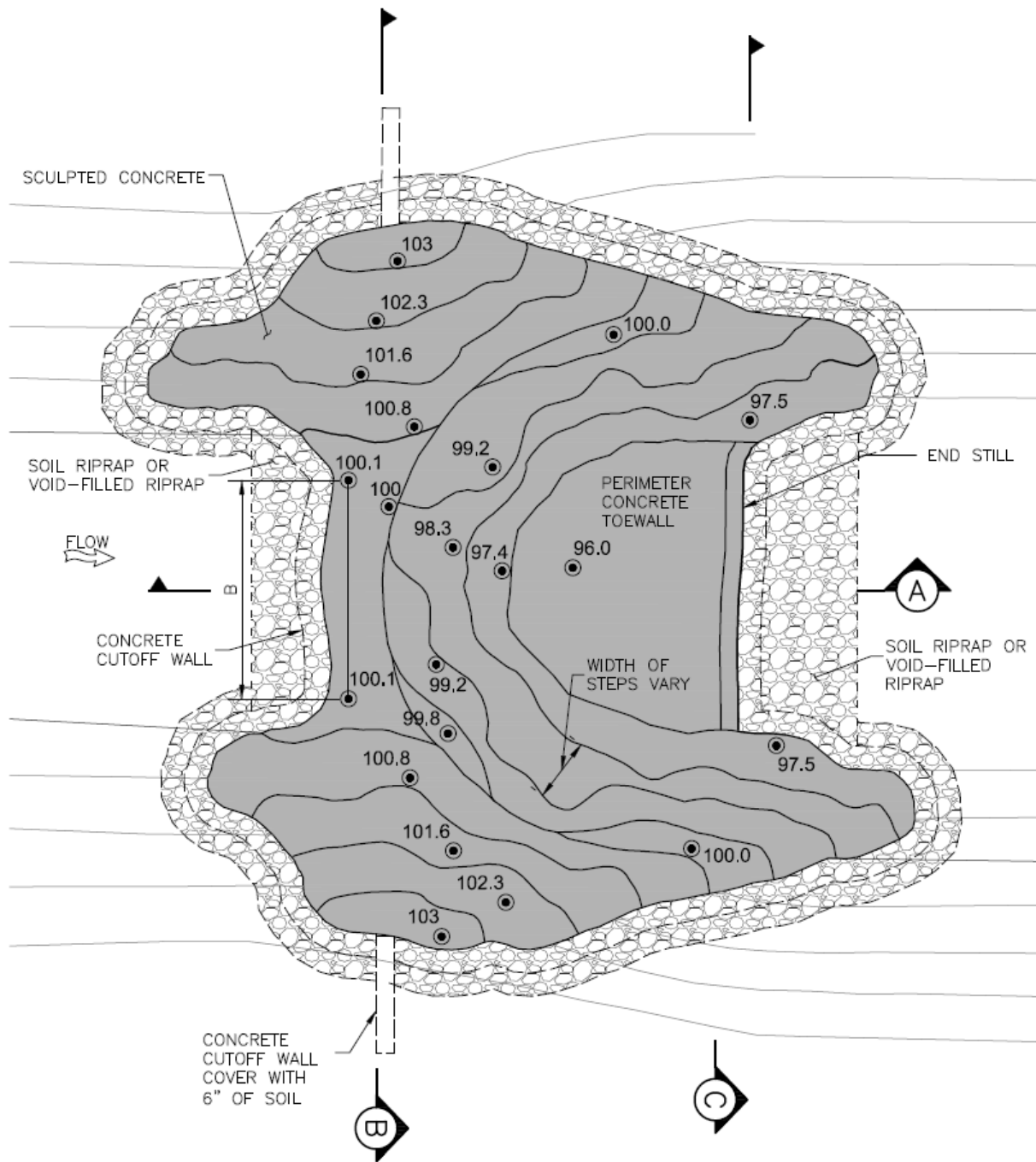


**Photograph 9-26.** Spray paint is used on the “skim coat” of a sculpted concrete structure prior to concrete placement to identify the locations for fracture lines and other features.

- **Skim Coat.** Keeping steel reinforcement clean can be a challenge. The use of blanketing can help. Another option is to apply a “skim coat” (also sometimes referred to as a “flash coat”). Skim coating consists of placing approximately 1 to 2 inches of shotcrete on the prepared subgrade. This alternative can be used with either concrete or shotcrete structures. Avoid the use of aggregate to stabilize or protect the subgrade. Skim coating will also protect the subgrade from weather and provide a clean and stable surface for placing and tying steel.
- **Concrete Placement.** Concrete placement is a quick process. In order to be properly prepared for a concrete pour, it is important to coordinate the desired finished structure appearance with the contractor. Example photographs of similar sedimentary rock can be used to help communicate the desired finish. A test panel or section is recommended when varied textures and finishing will be incorporated. Another successful approach is to spray paint fracture lines or mark locations on the subgrade where texturing or features are desired. It is imperative that the contractor have an adequate number of workers present to place the concrete, survey design grades, trowel and carve the concrete, as well as perform all other finishing details.

#### **Cautions Associated with Sculpted Concrete Construction**

1. Skill and experience on the part of the contractor helps produce an attractive structure.
2. Subgrade excavation/compaction and placement of reinforcing steel must conform to complex, irregular shapes and slopes within design tolerances.
3. Placing, shaping, and carving of concrete/shotcrete must take place within a narrow range of water content and a short window of time. This requires planning, favorable weather conditions, an adequately-sized crew, appropriate pace, and a high degree of organization on the contractor’s part.
4. Care needs to be taken to avoid overworking concrete/shotcrete as vertical faces are shaped and trowelled; otherwise, cracking and sloughing can occur.
5. Inspection and adjustment of grades to meet the design intent must take place during placement of concrete/shotcrete.
6. Skill is required to shape, carve and stain the exposed surfaces of the sculpted concrete in an attractive manner that emulates natural rock formations.
7. Consider hot and cold weather conditions to ensure satisfactory finishing and curing of the concrete/shotcrete.



**Figure 9-16. Example plan view of basic sculpted concrete drop structure**

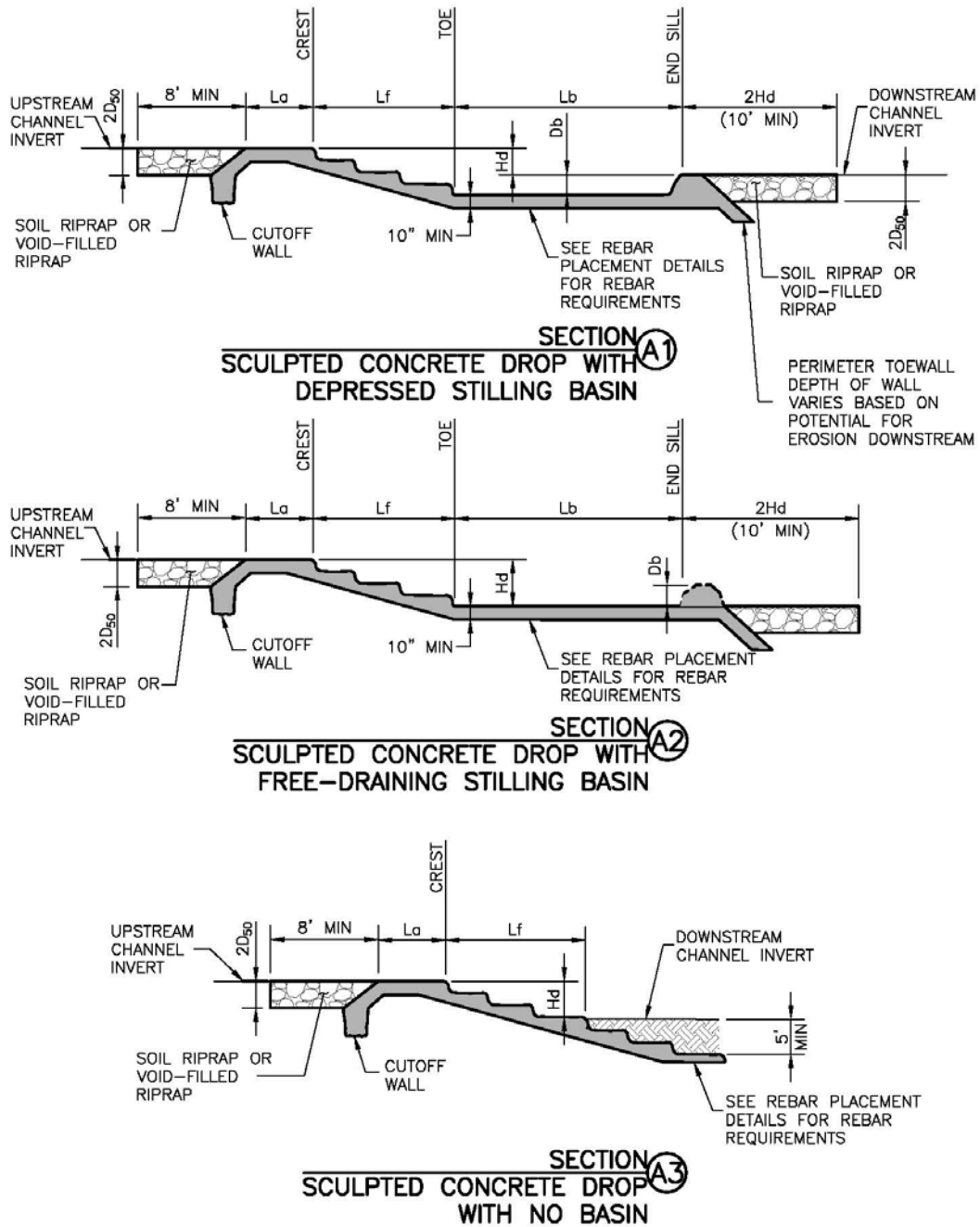
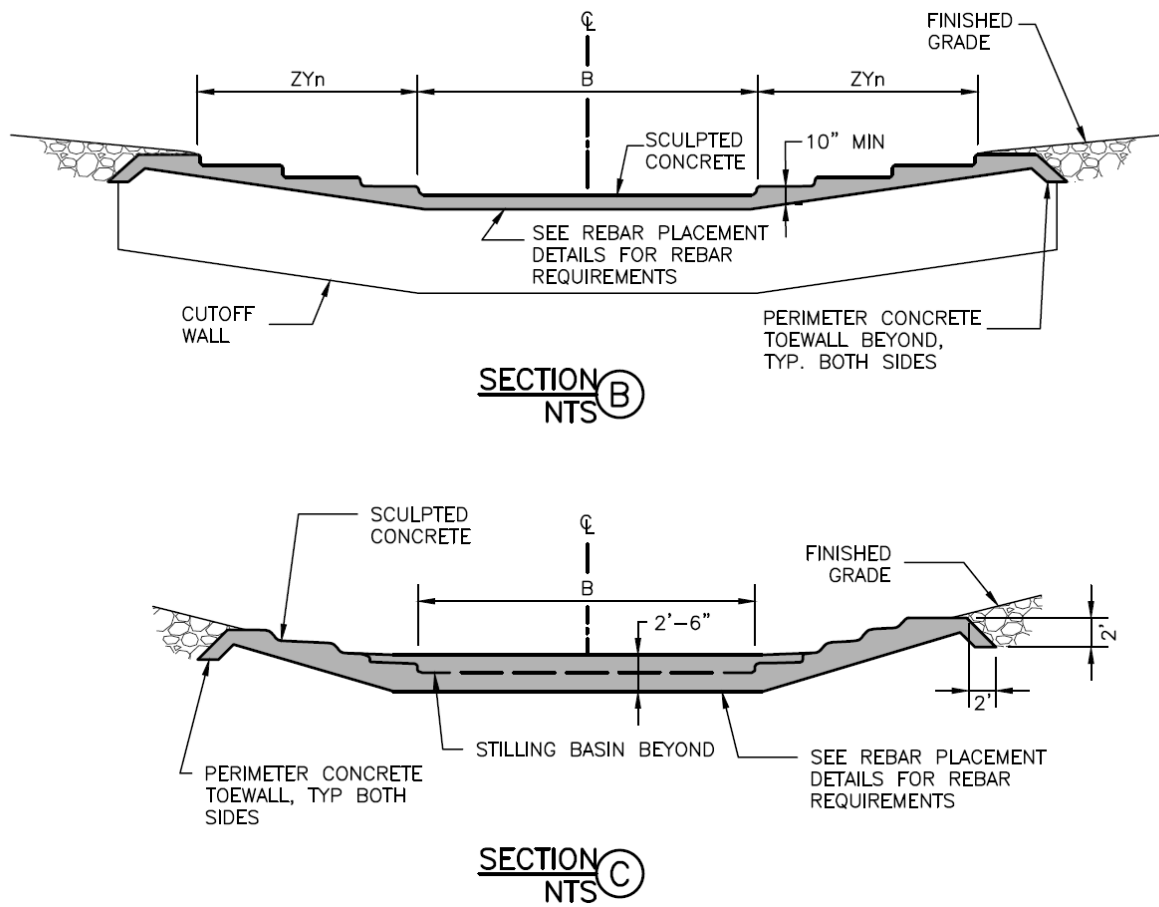
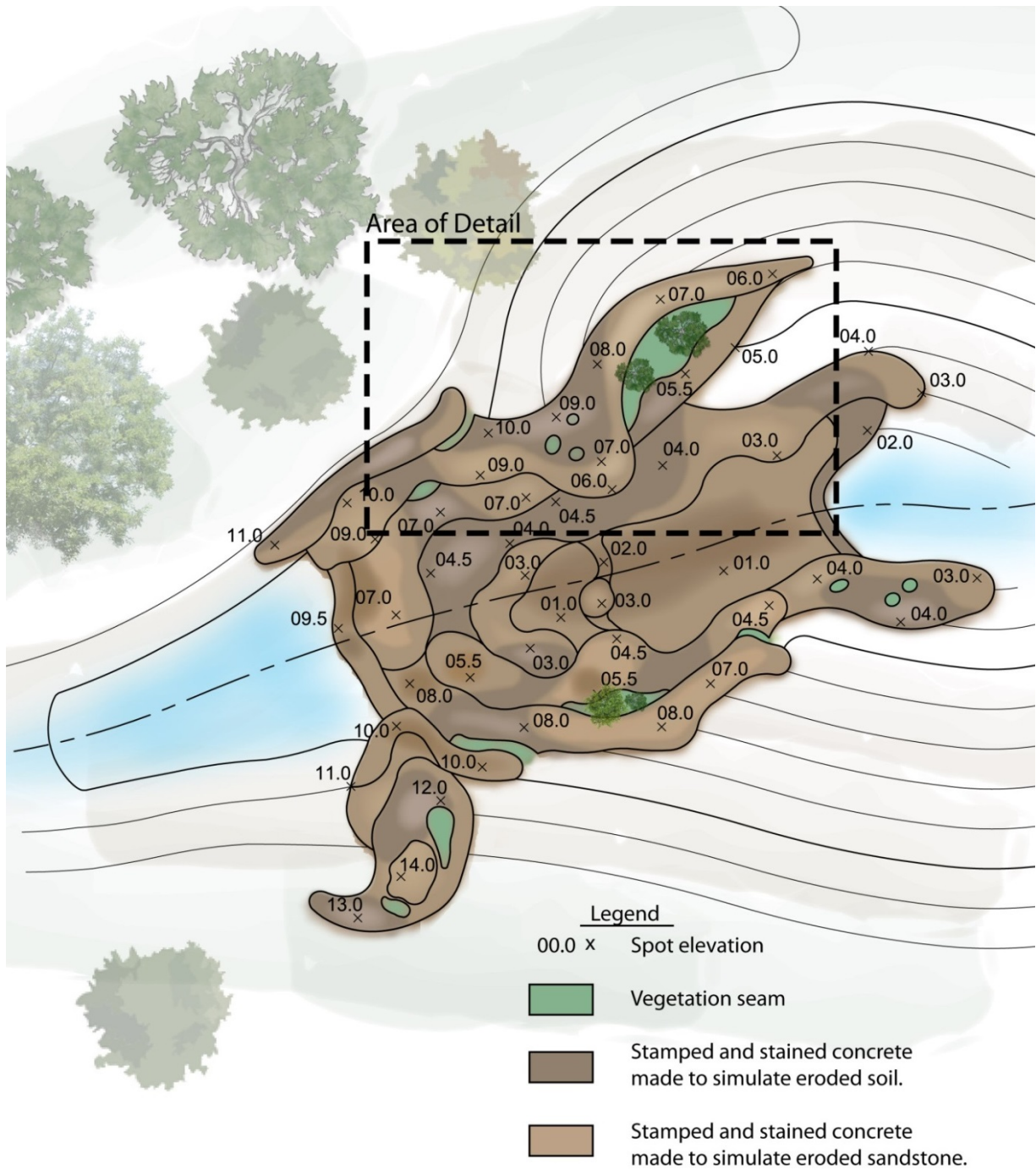


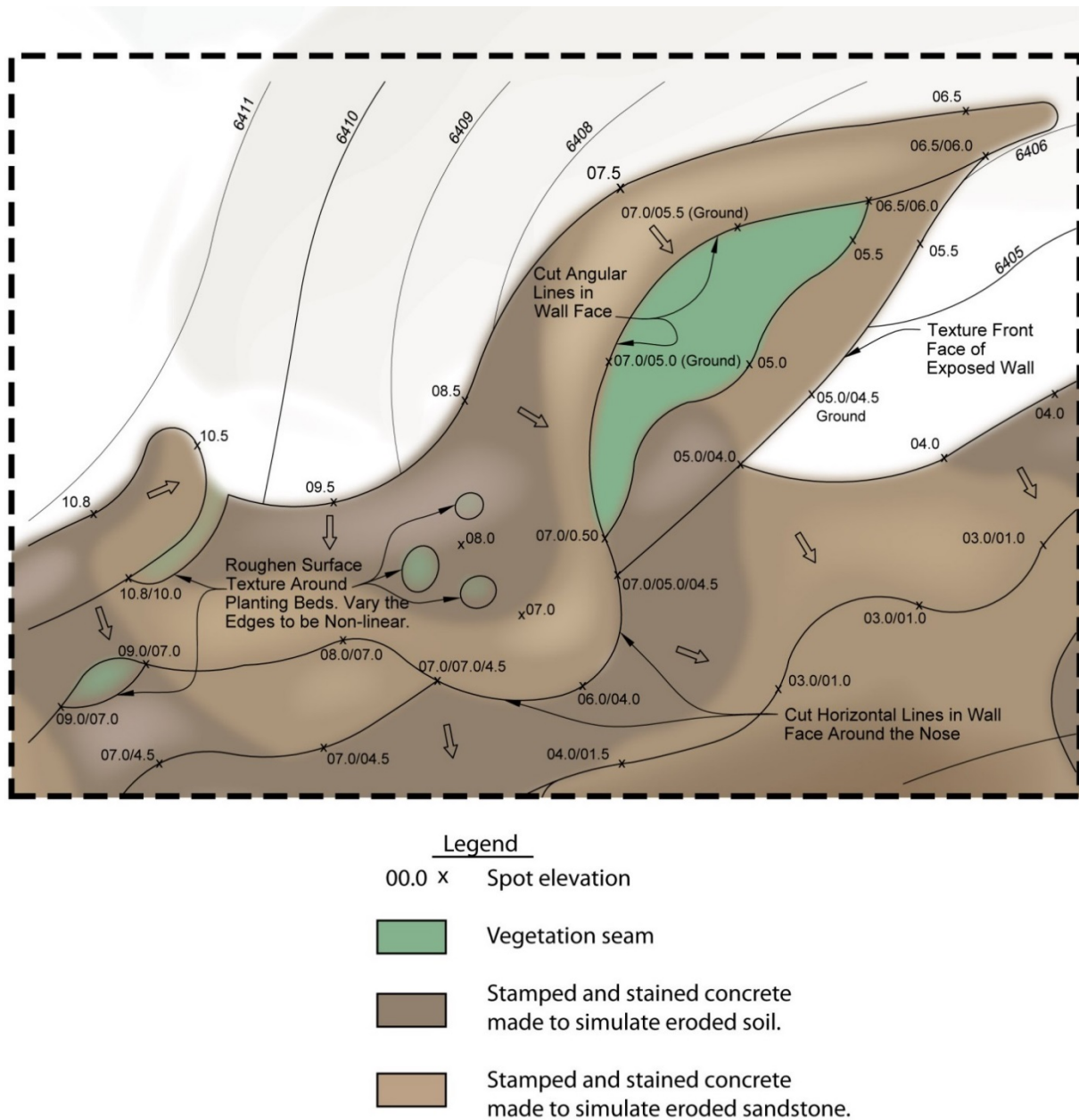
Figure 9-17. Example profiles of basic sculpted concrete drop structure



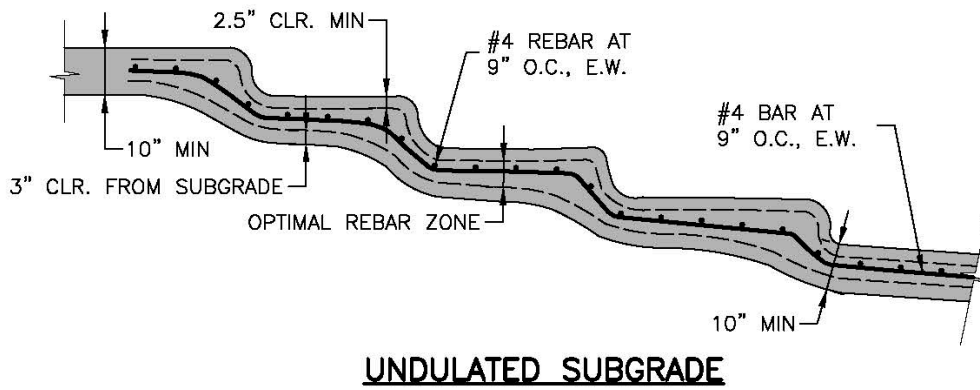
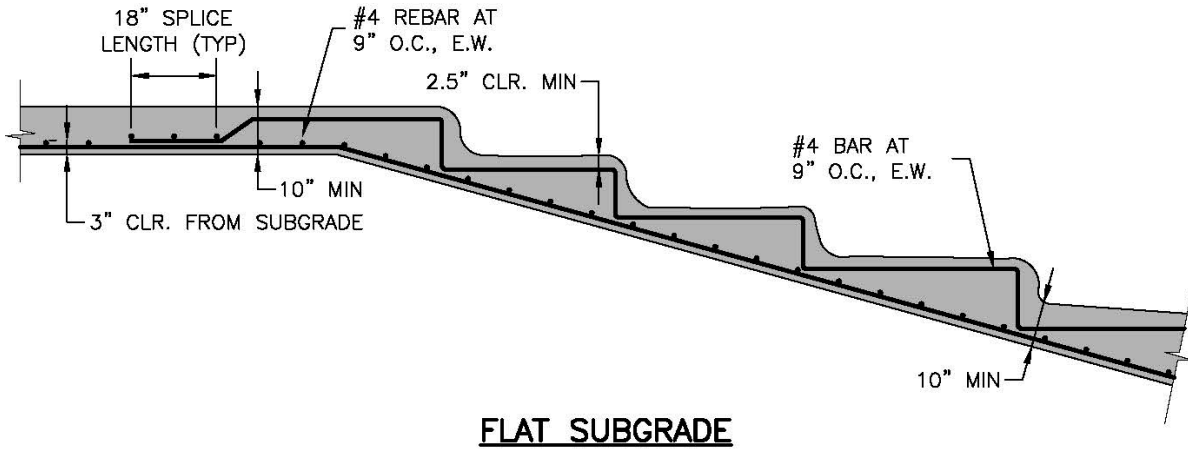
**Figure 9-18. Example cross sections of basic sculpted concrete drop structure**



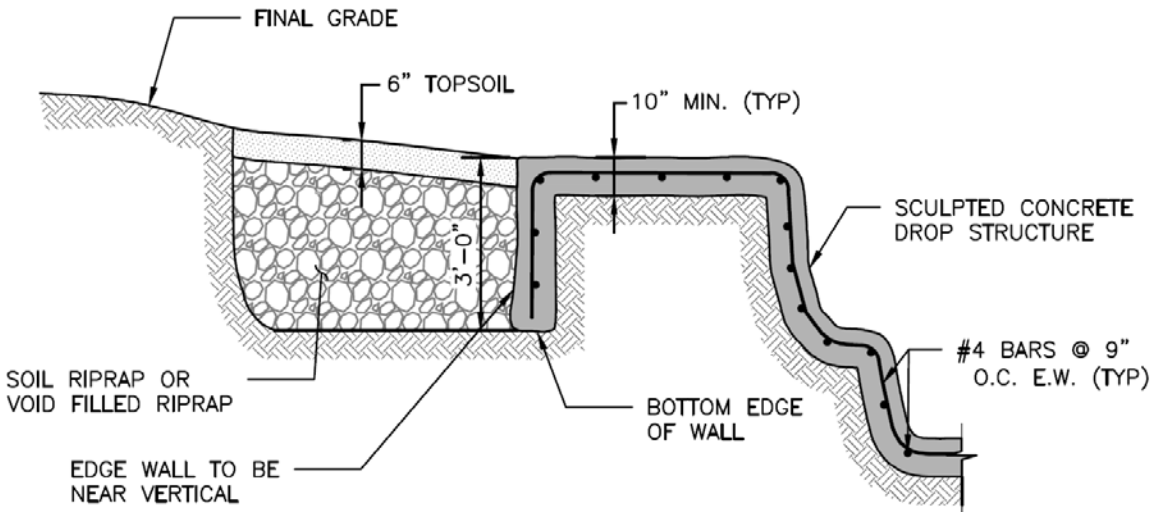
**Figure 9-19. Example plan view of complex sculpted concrete drop structure**



**Figure 9-20. Example detailed view of complex sculpted concrete drop structure**

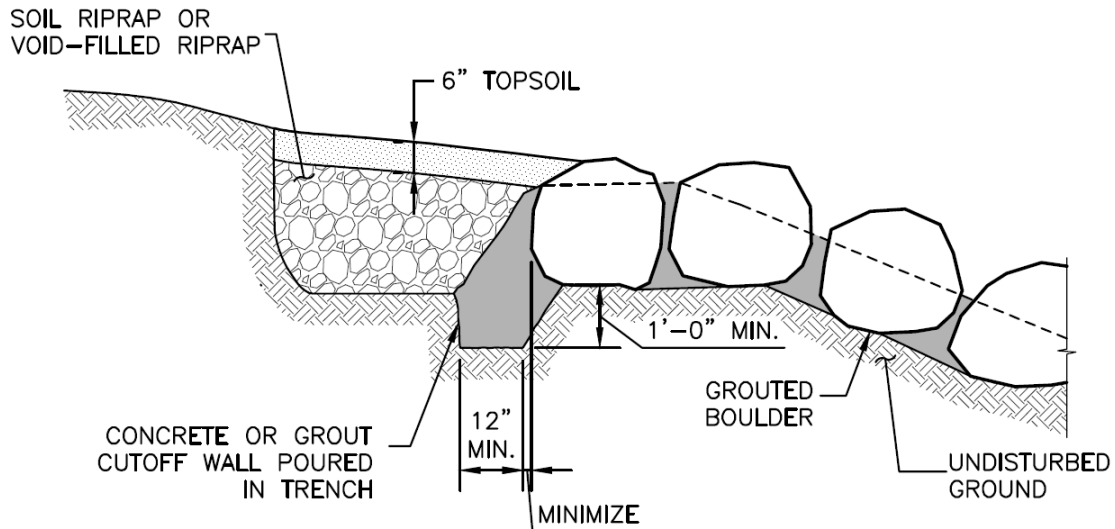


**Figure 9-21. Rebar placement for sculpted concrete drop structures**



- NOTES:**
1. DETAIL APPLIES TO THE PERIMETER OF THE ENTIRE STRUCTURE
  2. SEE THE REBAR PLACEMENT DETAIL FOR CLEARANCE FROM TOP AND BOTTOM OF THE STRUCTURE

**STRUCTURE EDGE WALL DETAIL (SC)**



**STRUCTURE EDGE WALL DETAIL (GSB)**

NTS

**Figure 9-22. Structure edge wall details**

## 2.8 Vertical Drop Structure Selection

### 2.8.1 Description

Vertical drop structures are discouraged for a number of safety reasons but can be an effective tool for controlling grade especially in locations where it is important to minimize the footprint of the drop structure and where there is little-to-no chance of recreation or access by minors. It is important to note that vertical structures can cause dangerous hydraulic conditions, including keeper waves, during wet weather and should be used only where appropriate. In addition, vertical drop structures are to be avoided due to impingement energy, related maintenance and turbulent hydraulic potential (ASCE and WEF 1992). Vertical drop structures should not be used on a channel where fish passage is a concern. Whenever used, it is recommended that the net drop structure height (upstream invert to downstream invert) be limited to 2 feet. This will allow for the addition of a 1-foot deep stilling basin immediately downstream of the crest. Drop structures frequently attract children during dry and wet conditions. Heights in excess of 3 feet are a falling hazard. In addition, a vertical drop structure should never be constructed where the design flow exceeds 500 cfs or a unit discharge of 35 cfs/ft.



**Photograph 9-27.** Keeping vertical drops small improves safety during both wet and dry conditions.

### 2.8.2 Design Criteria

The hydraulic phenomenon provided by a vertical drop structure is a jet of water that overflows the crest wall into a hard basin below. The jet hits the basin and is redirected horizontally. With sufficient tailwater, a hydraulic jump is initiated. Otherwise, the flow continues horizontally in a supercritical mode until the specific force of the tailwater is sufficient to force the jump. Energy is dissipated through turbulence in the hydraulic jump. Size the basin immediately downstream of the vertical wall to contain the supercritical flow and the erosive turbulent zone (see Figure 9-23).

1. The design approach uses the unit discharge in the main and low-flow channel to determine separately the water surface profile and jump location in these zones.

(Chow 1959) presents the hydraulic analysis for the “Straight Drop Spillway.”

#### **Vertical drops are not appropriate where:**

- Fish passage is needed,
- Design flow (over the length of the drop) exceeds 500 cfs or a unit discharge of 35 cfs/ft,
- Net drop height is greater than 2 feet, or
- The stream is boatable or there are other concerns related to in-channel safety.

The drop number,  $D_n$ , is defined as:

$$D_n = \frac{q^2}{(gY_f^3)} \quad \text{Equation 9-8}$$

Where:

$q$  = unit discharge (cfs/ft)

$Y_f$  = height from the crest to the basin floor (ft)

$g$  = acceleration of gravity = 32.2 ft/sec<sup>2</sup>

For hydraulic conditions at a point immediately downstream of where the nappe hits the basin floor, the following variables are defined as illustrated in Figure 9-23:

$$\frac{L_d}{Y_f} = 4.3D_n^{0.27}$$

$$\frac{Y_p}{Y_f} = 1.0D_n^{0.22}$$

$$\frac{Y_1}{Y_f} = 0.54D_n^{0.425}$$

$$\frac{Y_2}{Y_f} = 1.66D_n^{0.27}$$

Where:

$Y_f$  = height from the crest to the basin floor (ft)

$L_d$  = length from the crest wall to the point of impingement of the jet on the floor or the nappe length (ft)

$Y_p$  = pool depth under the nappe just downstream of the crest (ft)

$Y_1$  = flow depth on the basin floor just below where the nappe contacts the basin (ft)

$Y_2$  = tailwater depth (sequent depth) required to cause the jump to form at the point evaluated (ft)

In the case where the tailwater does not provide a depth equivalent to or greater than  $Y_2$ , the jet will wash downstream as supercritical flow until its specific force is sufficiently reduced to allow the jump to occur. This requires the designer to also check normal depth just downstream of the drop to ensure that it is equal or greater than  $Y_2$ .

### Drop Number for a Vertical Drop:

The drop number,  $D_n$  is a function of the unit discharge and vertical distance between the crest of the drop and the basin floor. From this value, the following can be determined:

- Location of the impingement,
- Depth of the pool under the nappe,
- Flow depth just downstream of the point of impingement,
- Sequent depth required to force the hydraulic jump

These values are necessary to properly place boulders (or baffles) for dissipation as well as determine the length of the basin.

Determination of the distance to the hydraulic jump,  $D_j$ , requires a separate water surface profile analysis for the main and low-flow zones (See Section 2.3.6 for additional guidance). Any change in tailwater affects the stability of the jump in both locations.

The hydraulic jump length,  $L_j$ , is approximated as 6 times the sequent depth,  $Y_2$ . Where tailwater provides a depth equivalent to or greater than  $Y_2$ , the design basin length,  $L_b$ , includes nappe length,  $L_d$ , and 60% of the jump length,  $L_j$ . (The subscripts "m" and "l" in Equations 9-8 and 9-9 refer to the main and low-flow zones, respectively). Where the tailwater is not sufficient to force the jump at the point of impingement, the distance from this point to the jump must be added to the basin length in the below equations.

At the main channel zone:

$$L_{bm} = L_{dm} + 60\% (6Y_{2m}) \quad \text{Equation 9-9}$$

At the low-flow zone, without boulders to break up the jet:

$$L_{bl} = L_{dl} + 60\% (6Y_{2l}) \quad \text{Equation 9-10}$$

1. Caution is advised regarding the higher unit flow condition in the low-flow zone. Large boulders and meanders in the low-flow zone of the basin may help dissipate the jet and may reduce the extent of armoring downstream along the low-flow channel. When large boulders are used as baffles in the impingement area of the low-flow zone, the low-flow basin length  $L_{bl}$ , may be reduced, but not less than  $L_{bm}$ . Boulders should project into the flow 0.6 to 0.8 times the critical depth. They should be located between the point where the nappe hits the basin and no closer than 10 feet from the basin end.
2. The basin floor elevation should be designed as depressed or free-draining similar to the stilling basin for stepped grouted boulder drop structures. A depressed basin adds to the effective tailwater depth for jump control. The basin is typically constructed of grouted boulders (24-inch minimum). The stilling basin must be evaluated for seepage uplift (Section 2.4) and other hydraulic forces.
3. Use a sill at the end of the stilling basin to assist in causing the hydraulic jump to form in the basin. Soil riprap or void filled riprap should be used downstream of the sill to minimize any local scour caused by the lift over the sill.
4. Use caution to avoid boulder placement such that flow impinges the channel side slopes of the basin.
5. Determine crest wall and footer dimensions by conventional structural methods. Underdrain requirements should be determined from seepage analysis.
6. Seepage uplift conditions require evaluations for each use. Complete a seepage analysis to provide for control and weight/size of components (see Section 2.4).

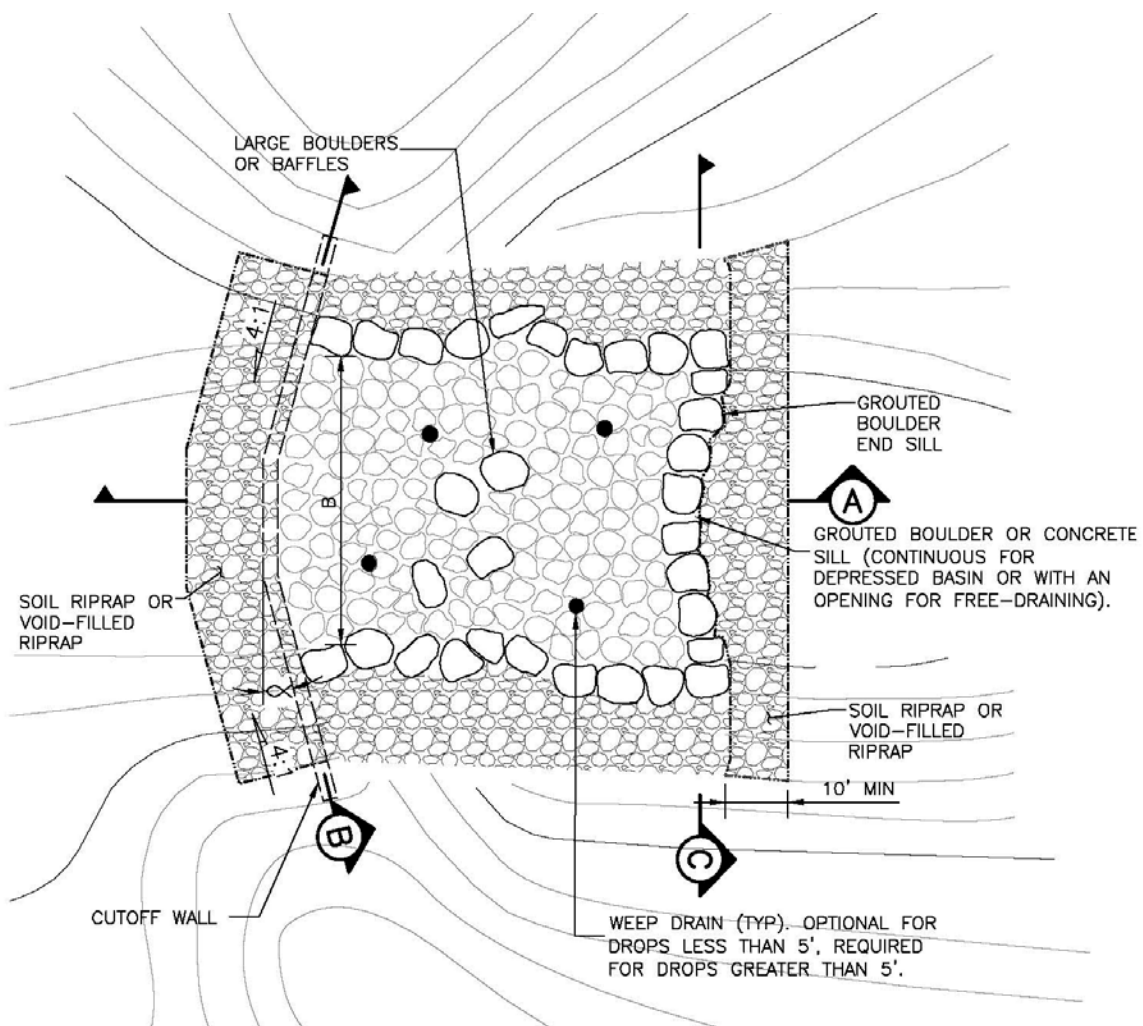
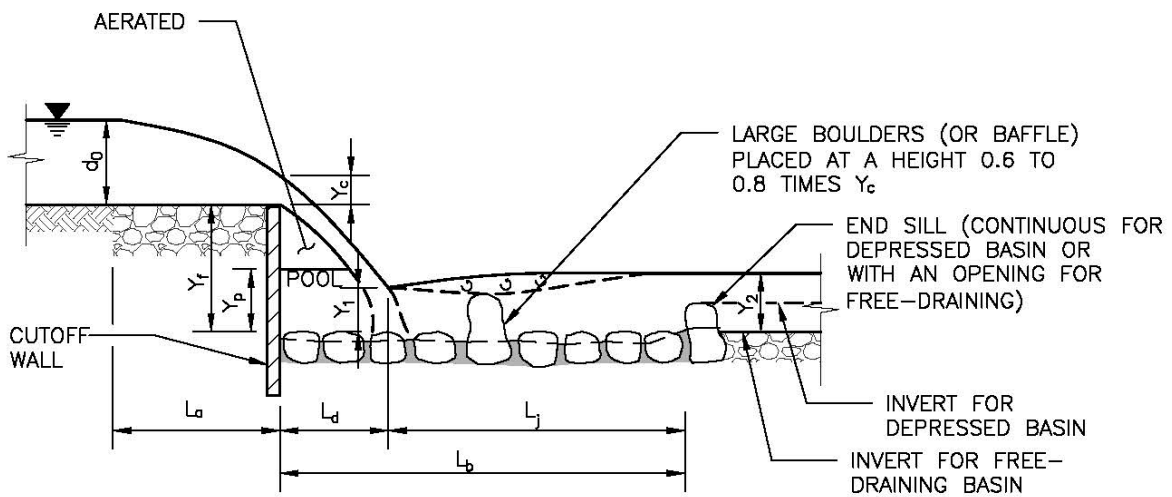


Figure 9-24. Example vertical drop structure plan

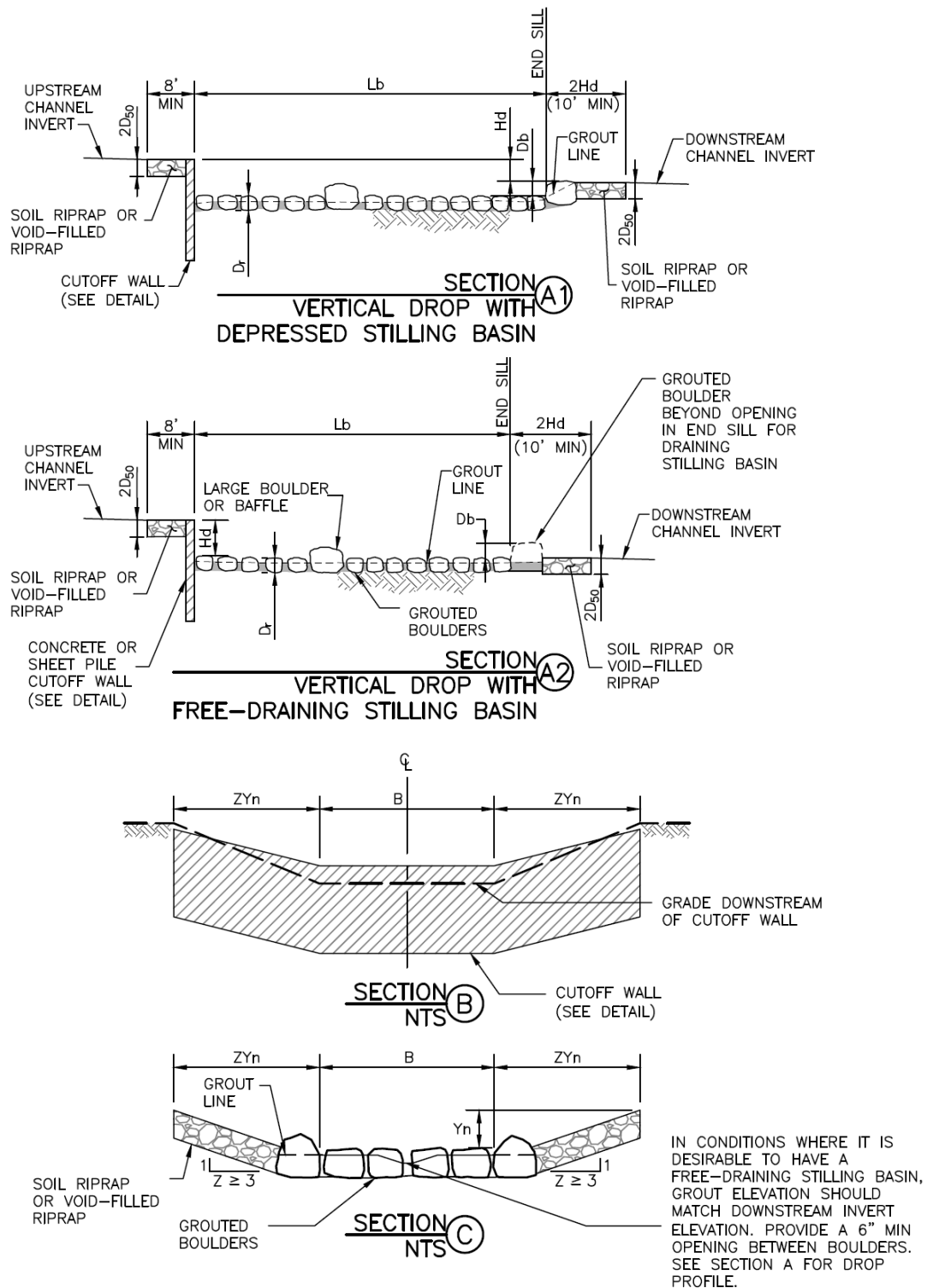


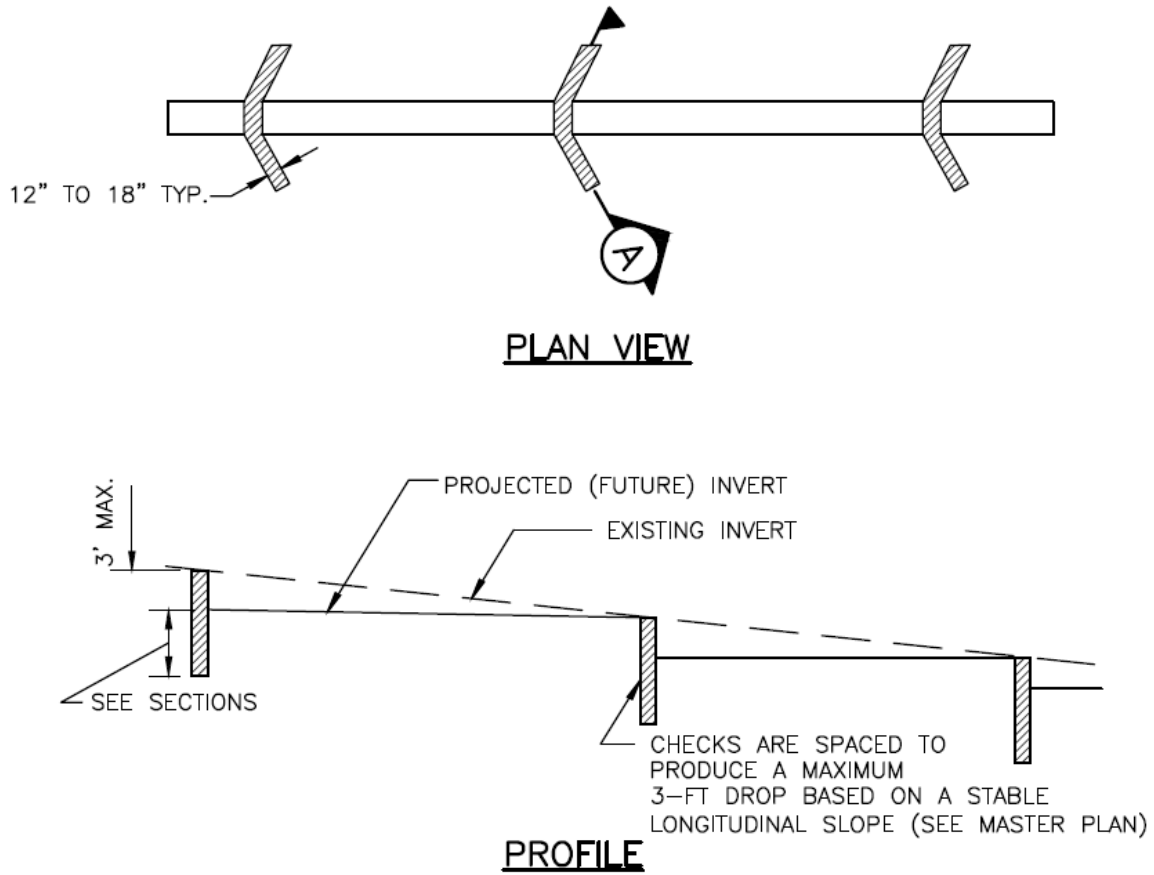
Figure 9-25. Example vertical drop structure sections

## 2.9 Low-flow Drop Structures and Check Structures

If a channel has not yet experienced significant erosion and degradation, but may degrade in the future, a number of options provide a level of reinforcement against future degradation. One approach is to install a standard drop structure and then backfill it to be mostly buried in the near term, but ready to handle additional grade difference as the channel invert lowers over time. Other approaches include:

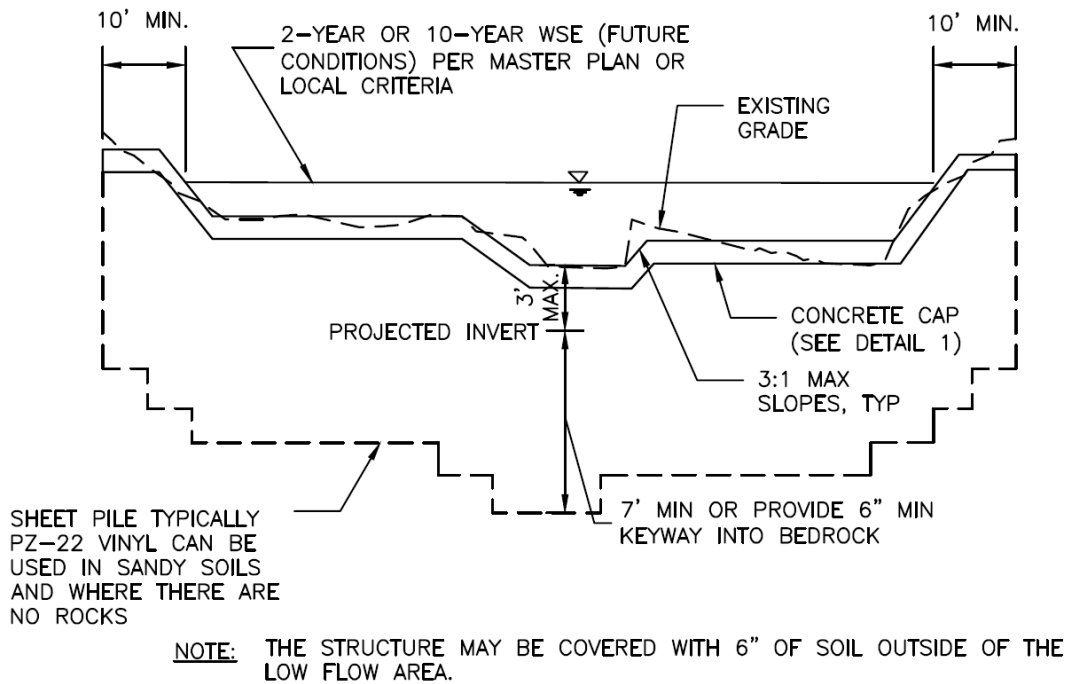
- **Low-flow Drop Structures.** Low-flow drop structures are small structures designed to provide control points and establish stable bed slopes within the low-flow channel. Erosion of the low-flow channel, if left uncontrolled, can cause degradation and destabilization of the entire channel. Low-flow drop structures must be tied securely into the banks of the low-flow channel and take advantage of backwater from downstream drop structures to reduce the likelihood of circumventing, also known as flanking, or “end-around” erosion as flow converges back to the low-flow channel from the main channel overbanks below the drop structure. Low-flow drop structures in themselves do not address erosion potential in the overbank areas outside of the low-flow channel. See the criteria in the Open Channel chapter when evaluating the stability of the existing channel. Note that the low-flow channel is referred to as the bankfull channel in other parts of this manual.
- **Check Structures with follow-up field observation program.** Check structure construction typically consists of driving sheet pile to a 10-foot depth and capping it with concrete or filling an excavated narrow trench (12” minimum width) with concrete (if soil and groundwater conditions permit trenching to a depth of six feet). Only specify concrete check structures where soils permit excavation of a narrow trench. Never over-excavate to form concrete checks. Extend the walls laterally as necessary to contain the 5- to 10-year flow (depending on local criteria), but no less than 2 feet above the top of the low-flow channel banks. This will reduce the risk of side cutting. Space check structures so that there is no more than a 3-foot net drop from the crest of the check to the projected downstream invert based on the estimated long-term equilibrium slope. Figure 9-26 illustrates sheet piling and concrete check structures and a typical concrete cap for sheet piling check structures. Additional protection (e.g., soil riprap or void-filled riprap) downstream of the check structure may be appropriate based on scour potential. Consider soil type, longitudinal slope, and other site-specific considerations when evaluating scour potential.

If a local government allows check structures, a follow-up field observation program is required to identify checks where erosion has exposed the face of the check structure, creating a significant drop in elevation from crest of the check to the elevation immediately downstream of the check. This vertical distance should not exceed 3 feet. Rehabilitative maintenance improvements may be necessary to install stable downstream erosion protection and convert the check to a drop structure (e.g., a grouted stepped boulder drop structure). Soil riprap placed downstream of the check structure can help as an interim condition to ensure the vertical distance does not exceed 3 feet. Vertical differences in excess of 3 feet present a fall hazard during dry weather and can increase potential for an overly retentive hydraulic during wet weather.

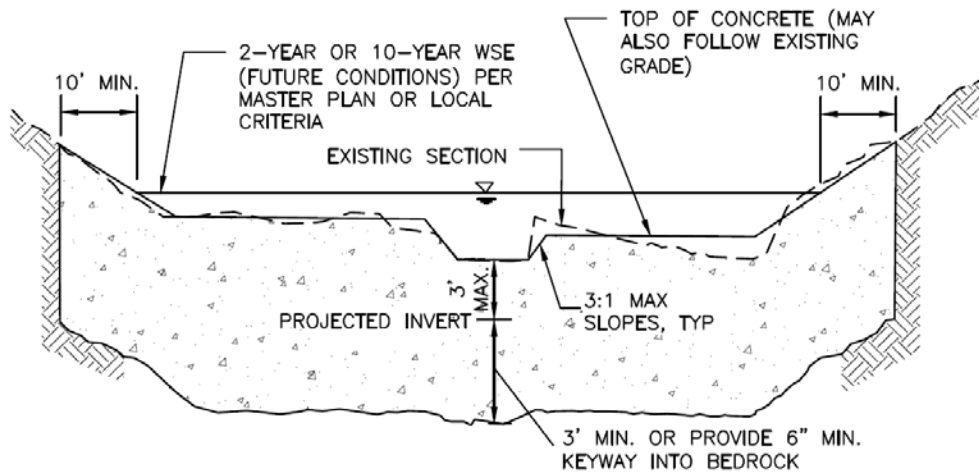


- NOTES:**
1. SHEET PILE IS PREFERRED AND MUST BE USED WHERE SOIL CANNOT HOLD A VERTICAL WALL.

**Figure 9-26. Check structure details (Part 1 of 3)**



**SECTION A1**  
**SHEET PILE CHECK**



- NOTES:**
1. TRENCH IN UNDISTURBED SOIL. FORM TOP 6" OF CHECK. DO NOT OVER EXCAVATE TO FORM WALLS OR CONSTRUCT A FOOTING.
  2. THE STRUCTURE MAY BE COVERED WITH 6" OF SOIL OUTSIDE OF THE LOW FLOW AREA.
  3. VIBRATE CONCRETE INTO TRENCH.

**SECTION A2**  
**CONCRETE CHECK**

**Figure 9-27. Check structure details (Part 2 of 3)**

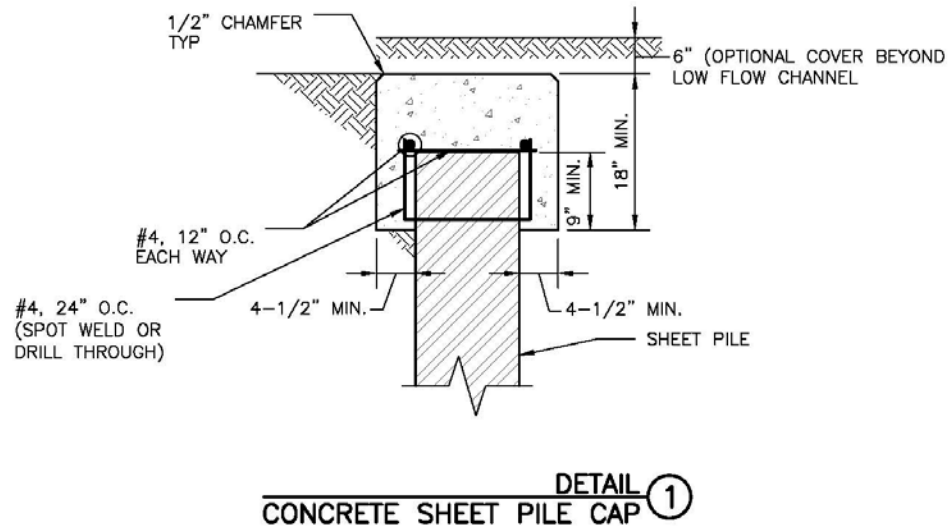


Figure 9-28. Check structure details (Part 3 of 3)

## 3.0 Pipe Outfalls and Rundowns

Pipe outlets represent a persistent problem due to concentrated discharges and turbulence of flow reaching this point of transition in an open channel. Too often, the designer focuses efforts on a culvert inlet and its sizing with outlet hydraulics receiving only passing attention. Appropriate pipe end treatment and downstream erosion protection at pipe outfalls is critical to protect the structural integrity of the pipe and to maintain the stability of the adjacent slope. Further discussion regarding appropriate treatment at pipe outfalls is included in the following sections.

The use of rundowns to convey storm runoff down a channel bank is discouraged due to their high rate of failure and the resulting maintenance and repair burden. Instead, use a pipe to convey runoff to a point just above the channel invert (normally 1 foot for small receiving streams or ponds and up to 2 feet for large receiving channels).

### 3.1 Pipe End Treatment

Pipe end treatment consists of a flared end section, toe wall, headwall, wingwall or combination of treatments to protect the outfall from failure and provide a stable transition from hard to soft conveyance elements. Further discussion regarding these treatments follows.

#### 3.1.1 Flared-End Sections and Toe Walls

Flared end sections may be installed on both the inlet and outlet ends of culverts or storm drain systems. Erosion is likely at the outlet and possible at the inlet. Construction of a concrete toe wall (cutoff) will protect the culvert from damage if inlet or outlet protection fails. At the outlet, provide scour protection including cutoff wall and use joint fasteners immediately upstream of the outlet. Protection at the upstream end can also help control seepage in the storm drain trench. See the Culverts chapter for discussion on inlet improvements.



**Photograph 9-28.** Pipe outfalls are recommended over rundowns due to the high failure rate of rundowns.



**Photograph 9-29.** Pipe end failure resulting in loss of the flared end section

Concrete toe walls include a footing and stem wall as shown in Figure 9-29 although the footing is optional for pipes 48 inches or less. Freezing depth should dictate the depth of the wall. The depth shown in the details represents freezing depth in the UDFCD region. Included is a design table for pipes 18 to 72 inches. The wall length shown allows an approximate 3(H):1(V) final ground slope from the flared-end section invert to the top outside edge of wall. Note that for large diameter flared-end sections, the wall lengths are quite large. It may be advantageous to use a combination headwall/wingwall approach or consider incorporating boulders for pipes larger than 36 inches in diameter. Always evaluate public safety including the need for pedestrian railing where a potential fall of 36 inches or more as possible. Along with the toe wall, install two joint fasteners between the flared end section and the last pipe section. Install these roughly at the ten o'clock and two o'clock positions and trim joint fastener threads flush with the interior bolts. Left untrimmed, these can catch debris and reduce pipe capacity. Joint fasteners are not necessary for flared end sections on the entrance of culverts or storm drains.

Figures 9-29 and 9-30 are applicable to both ends of a culvert or storm drain system. It is the design engineer's responsibility to assess the need for a cutoff wall. Factors to consider include:

- The slope of the culvert or storm drain system is steep;
- The surrounding subsoils are granular or otherwise susceptible to erosion and/or piping;
- Potential for the roadway to wash out and the associated impact to public safety.

### 3.1.2 Concrete Headwall and Wingwalls

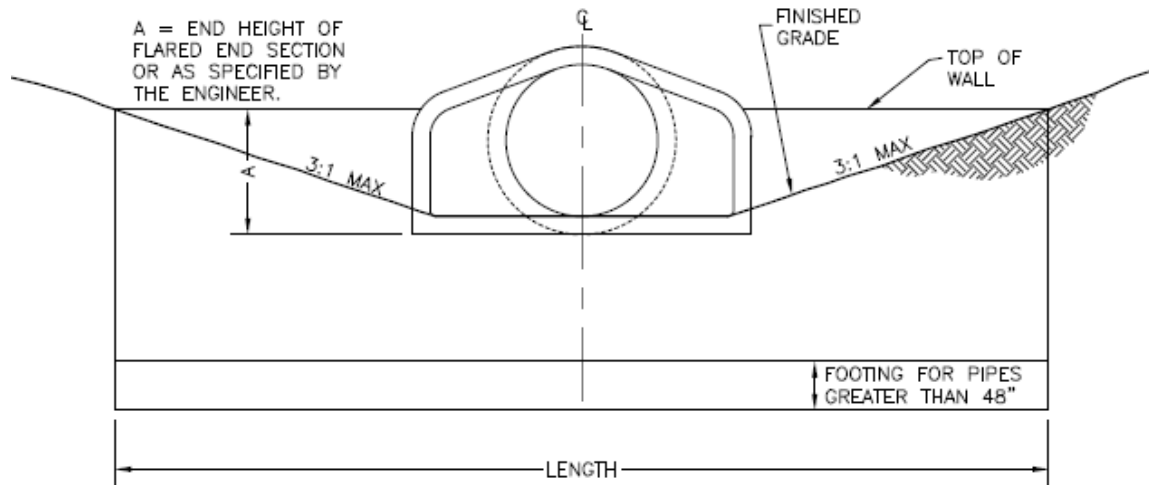
Concrete headwalls are an acceptable alternative to flared-end sections at pipe inlets and outlets.

Figure 9-31 provides design guidance and a headwall design table for the design of a concrete headwall at a pipe inlet or outlet. When a 3(H):1(V) final ground slope from the pipe invert to the top outside edge of wall is used, the wall length can become quite long. Headwalls can be paired with wingwalls or boulders in order to reduce the overall headwall length. For 18" to 36" diameter pipes, headwalls can be paired with loosely placed boulders as shown in Figure 9-32. The addition of boulders can enhance the appearance of the end treatment and significantly reduce the wall length.

Storm drain outfalls into large river systems (e.g., the South Platte River) often require special consideration with respect to the channel bank geometry and base flow water surface elevation.

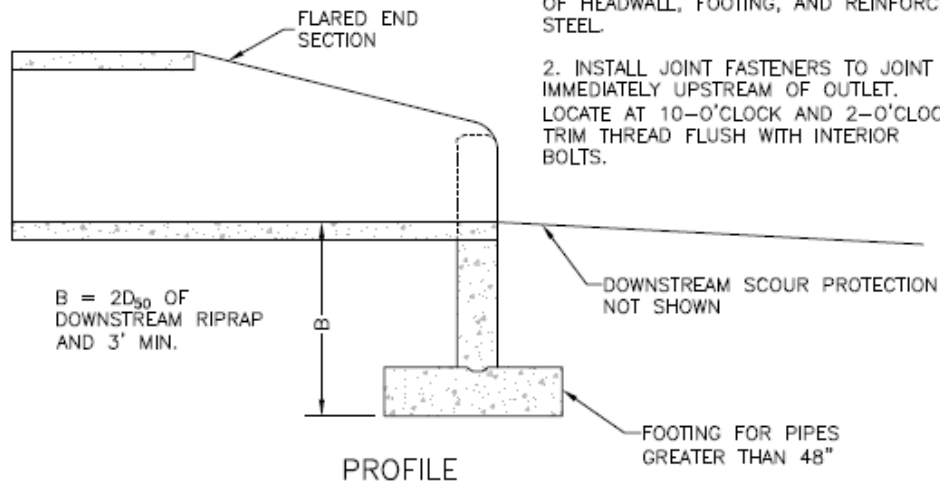
Figure 9-33 provides general layout information for the construction of a headwall with wingwalls. It is the design engineer's responsibility to evaluate the site conditions and provide final design of headwall, wingwalls, footings, and reinforcing steel.

On large receiving streams, UDFCD encourages the use of wingwalls that are constructed perpendicular to the receiving channel centerline (or headwall), thereby reducing the impact to the channel overbanks. Further discussion regarding structure requirements for outfalls into large river systems is in Section 3.2.4.



**ELEVATION VIEW**

- NOTES:
1. IT IS THE DESIGN ENGINEER'S RESPONSIBILITY TO EVALUATE THE SITE CONDITIONS AND PROVIDE FINAL DESIGN OF HEADWALL, FOOTING, AND REINFORCING STEEL.
  2. INSTALL JOINT FASTENERS TO JOINT IMMEDIATELY UPSTREAM OF OUTLET. LOCATE AT 10-O'CLOCK AND 2-O'CLOCK. TRIM THREAD FLUSH WITH INTERIOR BOLTS.

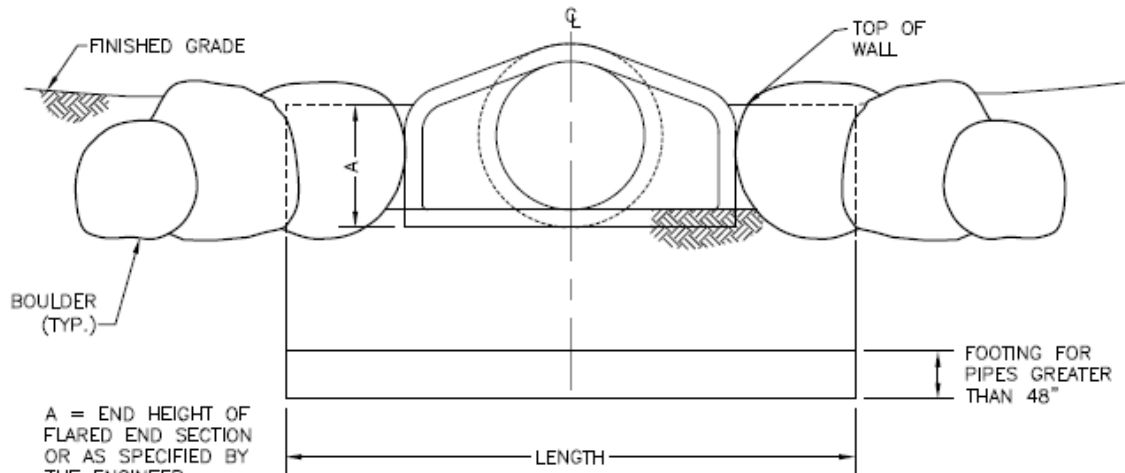


**PROFILE**

**HEADWALL DESIGN TABLE**

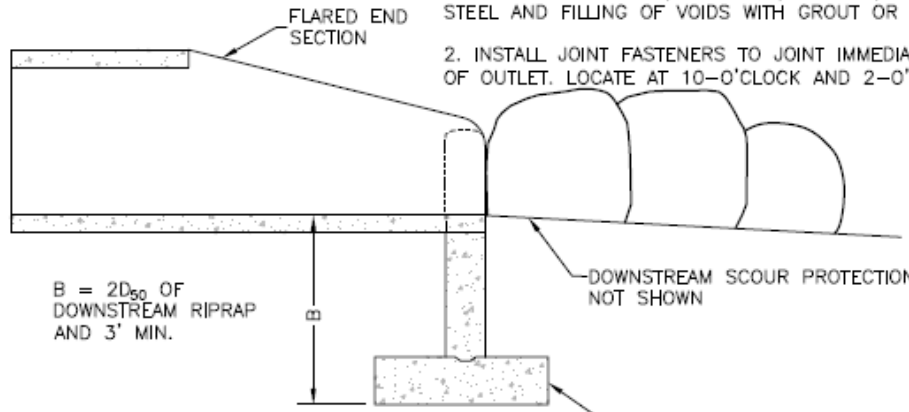
PIPE SIZE	LENGTH, MIN
18"	7'-0"
24"	8'-0"
30"	10'-0"
36"	12'-6"
42"	15'-9"
48"	17'-6"
54"	19'-6"
60"	21'-6"
66"	22'-6"
72"	24'-0"

**Figure 9-29. Flared end section (FES) headwall concept**



**ELEVATION VIEW**

NOTES:  
 1. IT IS THE DESIGN ENGINEER'S RESPONSIBILITY TO EVALUATE THE SITE CONDITIONS AND PROVIDE FINAL DESIGN OF BOULDER SIZES AND PLACEMENT, HEADWALL, FOOTING, REINFORCING STEEL AND FILLING OF VOIDS WITH GROUT OR ROCK.

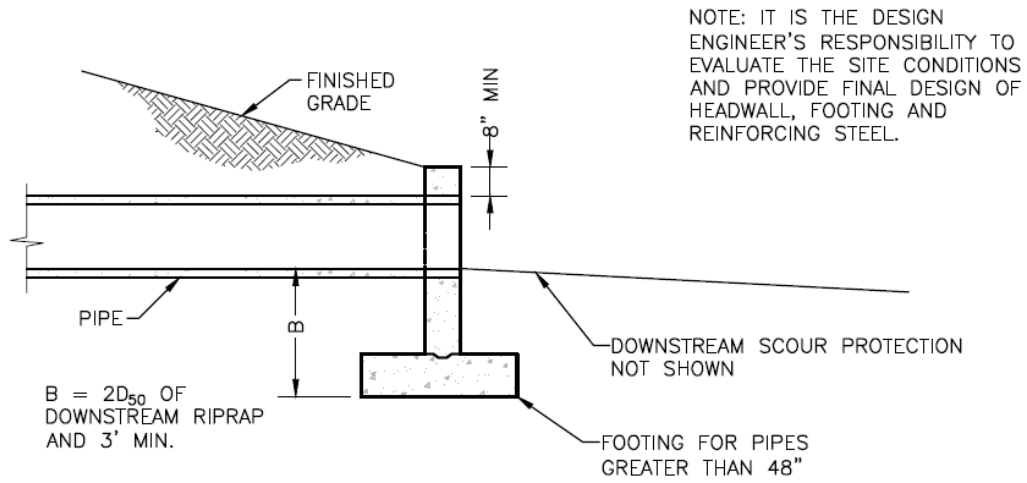
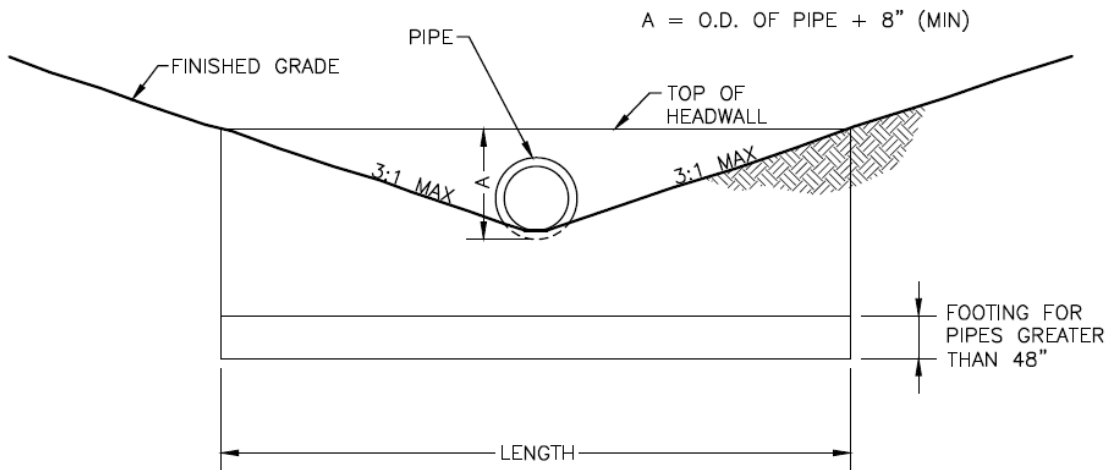


**PROFILE**

**TOEWALL DESIGN TABLE**

PIPE SIZE	LENGTH, MIN.
18"	7'-0"
24"	8'-0"
30"	10'-0"
36"	12'-0"
42"	12'-6"
48"	13'-0"
54"	13'-6"
60"	14'-0"
66"	14'-6"
72"	15'-0"

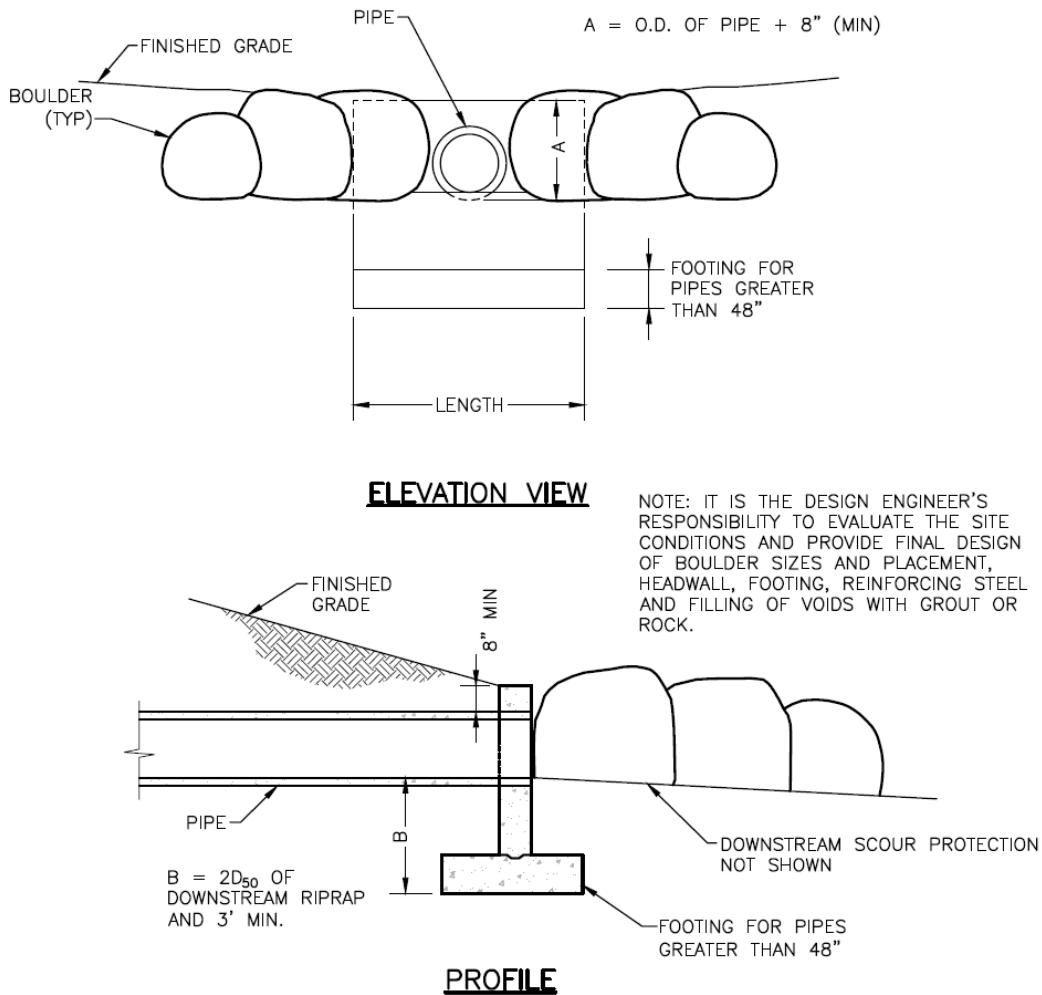
**Figure 9-30. Flared end section (FES) headwall concept**



**HEADWALL DESIGN TABLE**

PIPE SIZE	LENGTH, MIN
18"	15'-9"
24"	19'-6"
30"	23'-4"
36"	27'-0"
42"	30'-9"
48"	34'-6"

**Figure 9-31. Pipe headwall concept**

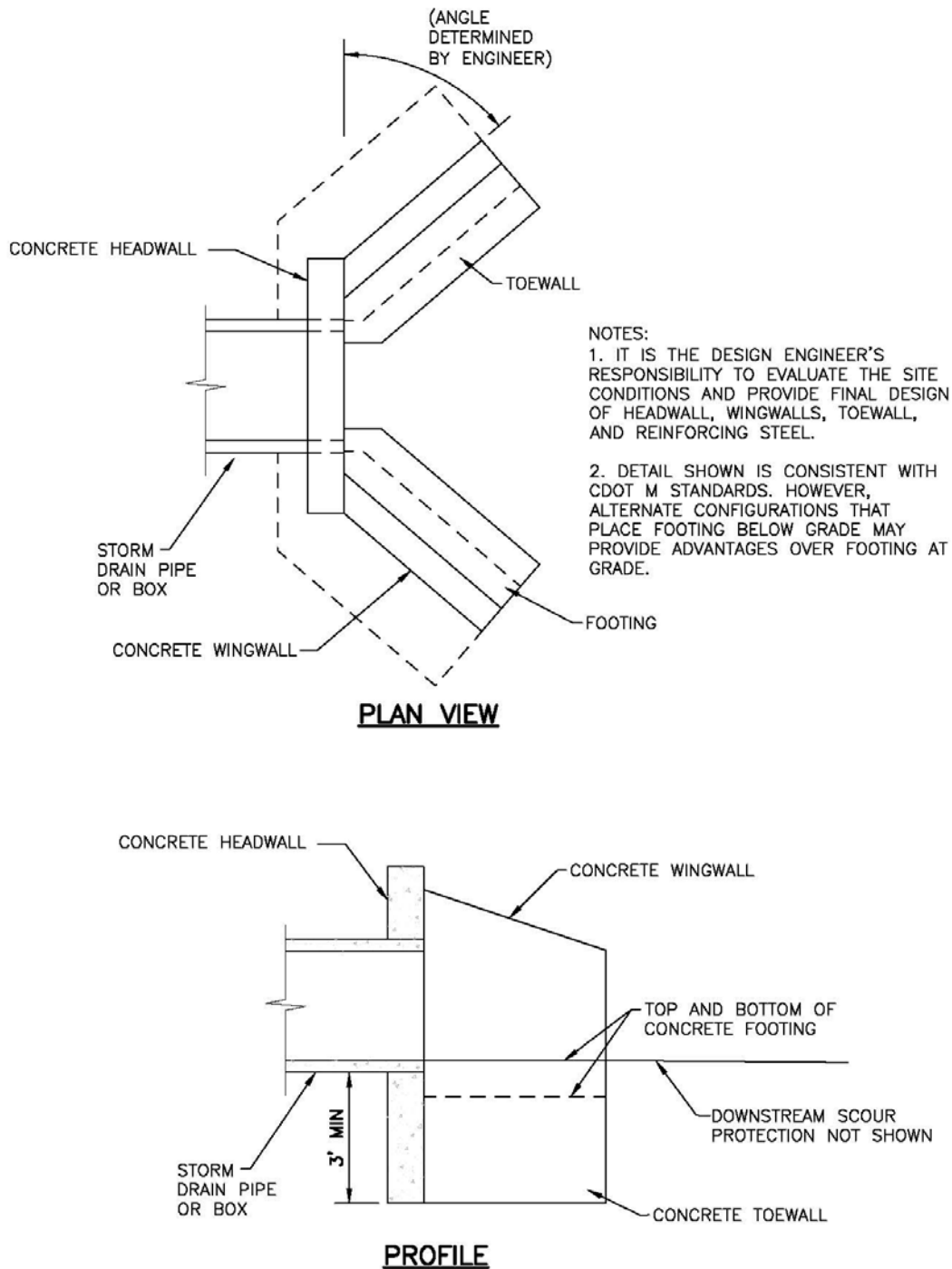


**HEADWALL DESIGN TABLE**

PIPE SIZE	LENGTH, MIN
18"	7'-0"
24"	8'-0"
30"	8'-6"
36"	9'-0"
42"	9'-6"
48"	10'-0"

**PIPE HEADWALL DETAIL**  
**(WITH BOULDERS)**

**Figure 9-32. Pipe headwall with boulders concept**



**Figure 9-33. Pipe headwall/wingwall concept**

### 3.2 Energy Dissipation and Erosion Protection

Local scour is typified by a scour hole produced at a pipe or culvert outlet. This is the result of high exit velocities, and the effects extend only a limited distance downstream. Coarse material scoured from the circular or elongated hole is deposited immediately downstream, often forming a low bar. Finer material moves farther downstream. The dimensions of the scour hole change due to sedimentation during low flows and the varying erosive effects of storm events. The scour hole is generally deepest during passage of the peak flow. Methods for predicting scour hole dimensions are found in the *Hydraulic Design of Energy Dissipators for Culverts and Channels* (FHWA 1983 and 2000).

Protection against scour at outlets ranges from limited riprap placement to complex and expensive energy dissipation devices. Pre-formed scour holes (approximating the configuration of naturally formed holes) dissipate energy while providing a protective lining to the streambed.

This section addresses energy dissipation and erosion control measures that can be used to minimize or eliminate local scour at a pipe outlet. The following measures are discussed:

- Riprap Apron
- Low Tailwater Basin
- Grouted Boulders
- Impact Basin

In general, all of these measures pose risks to the public. Discourage public access and minimize the risk of falls at these structures.

#### Scour and Stream Degradation

Scour is typically found at culvert outlets and other isolated transitional areas within a stream. Frequently, scour holes fill in with sediment over time only to appear again during infrequent high flows.

Degradation is a phenomenon that is independent of culvert performance. Natural causes can produce a lowering of the streambed over time. Contributing factors include the slope of the stream and the size and availability of the sediment load. Degradation can also be a result of other constructed features such as upstream detention or increased watershed imperviousness. The identification of a degrading stream is an essential part of the original site investigation. Discussion of this subject is in the *Open Channels* chapter.

### 3.2.1 Riprap Apron

This section addresses the use of riprap for erosion protection downstream of conduit and culvert outlets. Refer to the *Open Channels* chapter for additional information on applications for and placement of riprap. Those criteria will be useful in design of erosion protection for conduit outlets. When incorporating a drop into the outfall use Figure 9-40 or 9-41.

#### Rock Size

The procedure for determining the required riprap size downstream of a conduit outlet is in Section 3.2.3.

#### Configuration of Riprap Apron

Figure 9-34 illustrates typical riprap protection of culverts at conduit outlets.

#### Extent of Protection

The length of the riprap protection downstream from the outlet depends on the degree of protection desired. If it is necessary to prevent all erosion, the riprap must extend until the velocity decreases to an acceptable value. The acceptable major event velocity is set at 5 ft/sec for non-cohesive soils and at 7 ft/sec for erosion resistant soils. The rate at which the velocity of a jet from a conduit outlet decreases is not well known. The procedure recommended here assumes the rate of decrease in velocity is related to the angle of lateral expansion,  $\theta$ , of the jet. The velocity is related to the expansion factor,  $(1/(2\tan\theta))$ , which can be determined directly using Figure 9-35 or Figure 9-36, by assuming that the expanding jet has a rectangular shape:

$$L_p = \left( \frac{1}{2 \tan \theta} \right) \left( \frac{A_t}{Y_t} - W \right) \quad \text{Equation 9-11}$$

Where:

$L_p$  = length of protection (ft)

$W$  = width of the conduit (ft, use diameter for circular conduits)

$Y_t$  = tailwater depth (ft)

$\theta$  = the expansion angle of the culvert flow

and:

$$A_t = \frac{Q}{V} \quad \text{Equation 9-12}$$

Where:

$Q$  = design discharge (cfs)

$V$  = the allowable non-eroding velocity in the downstream channel (ft/sec)

$A_t$  = required area of flow at allowable velocity (ft<sup>2</sup>)

In certain circumstances, Equation 9-11 may yield unreasonable results. Therefore, in no case should  $L_p$  be less than  $3H$  or  $3D$ , nor does  $L_p$  need to be greater than  $10H$  or  $10D$  whenever the Froude parameter,  $Q/WH^{1.5}$  or  $Q/D^{2.5}$ , is less than 8.0 or 6.0, respectively. Whenever the Froude parameter is greater than these maximums, increase the maximum  $L_p$  required by  $\frac{1}{4} D_c$  or  $\frac{1}{4} H$  for circular or rectangular (box) culverts, respectively, for each whole number by which the Froude parameter is greater than 8.0 or 6.0, respectively.

Once  $L_p$  has been determined, the width of the riprap protection at the furthest downstream point should be verified. This dimension is labeled “T” on Figure 9-34. The first step is to solve for  $\theta$  using the results from Figure 9-35 or 9-36:

$$\theta = \tan^{-1}\left(\frac{1}{2(\text{ExpansionFactor})}\right) \quad \text{Equation 9-13}$$

Where:

Expansion Factor = determined using Figure 9-35 or 9-36

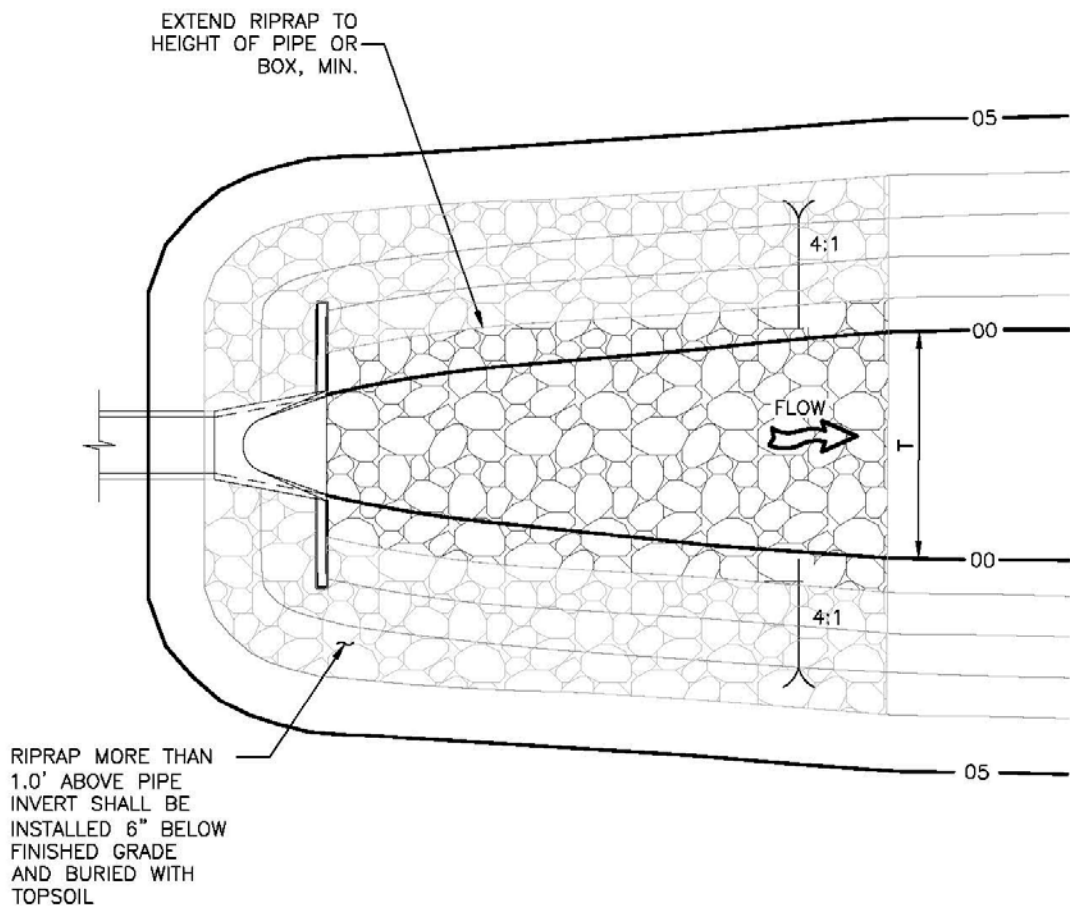
T is then calculated using the following equation:

$$T = 2(L_p \tan \theta) + W \quad \text{Equation 9-14}$$

### Multiple Conduit Installations

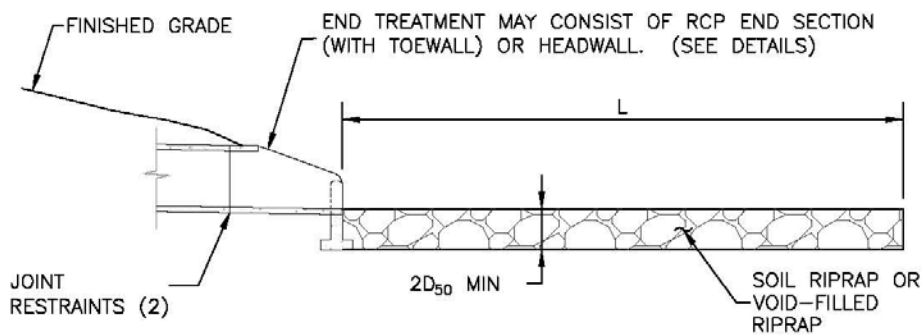
The procedures outlined in this section can be used to design outlet erosion protection for multi-barrel culvert installations by replacing the multiple barrels with a single hydraulically equivalent hypothetical rectangular conduit. The dimensions of the equivalent conduit may be established as follows:

1. Distribute the total discharge,  $Q$ , among the individual conduits. Where all the conduits are hydraulically similar and identically situated, the flow can be assumed to be equally distributed; otherwise, the flow through each barrel must be computed.
2. Compute the Froude parameter  $Q_i/D_{ci}^{2.5}$  (circular conduit) or  $Q_i/W_iH_i^{1.5}$  (rectangular conduit), where the subscript  $i$  indicates the discharge and dimensions associated with an individual conduit.
3. If the installation includes dissimilar conduits, select the conduit with the largest value of the Froude parameter to determine the dimensions of the equivalent conduit.
4. Make the height of the equivalent conduit,  $H_{eq}$ , equal to the height, or diameter, of the selected individual conduit.
5. The width of the equivalent conduit,  $W_{eq}$ , is determined by equating the Froude parameter from the selected individual conduit with the Froude parameter associated with the equivalent conduit,  $Q/W_iH_{eq}^{1.5}$ .



**PLAN VIEW**

NTS



**PROFILE**

NTS

**Figure 9-34. Riprap apron detail for culverts in-line with the channel**

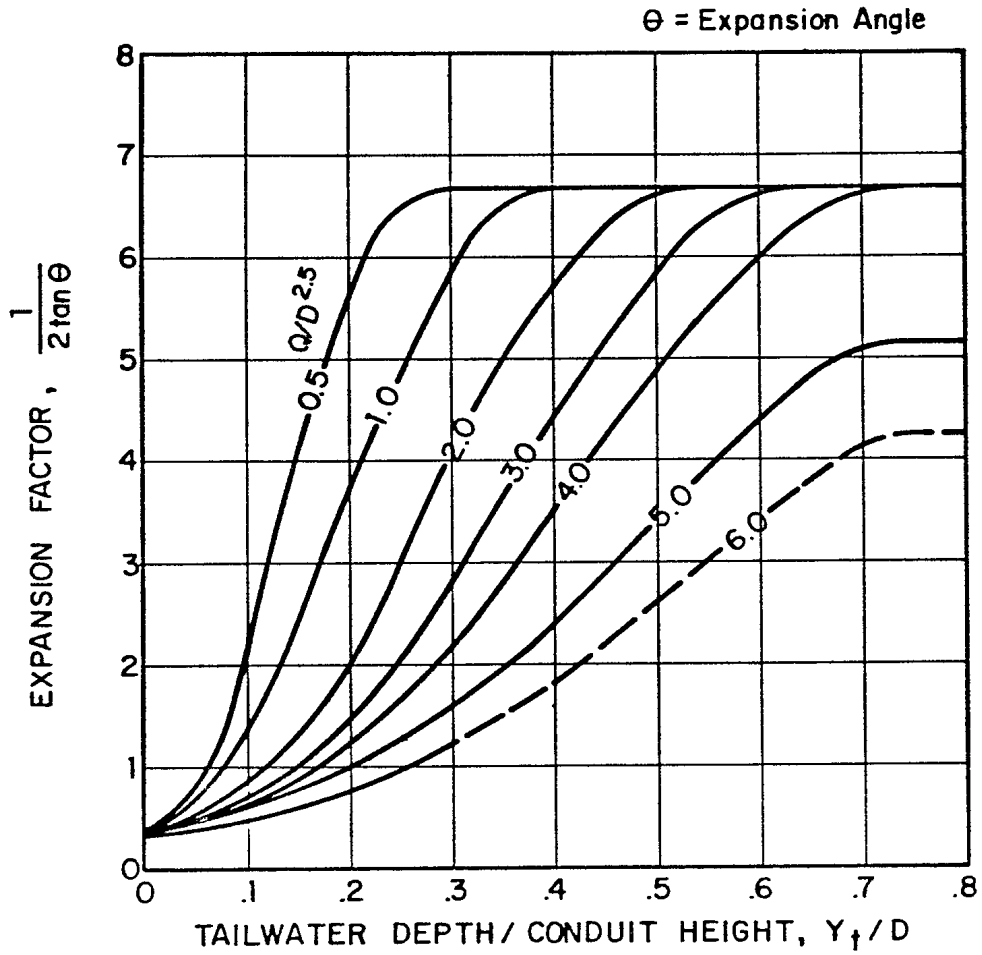


Figure 9-35. Expansion factor for circular conduits

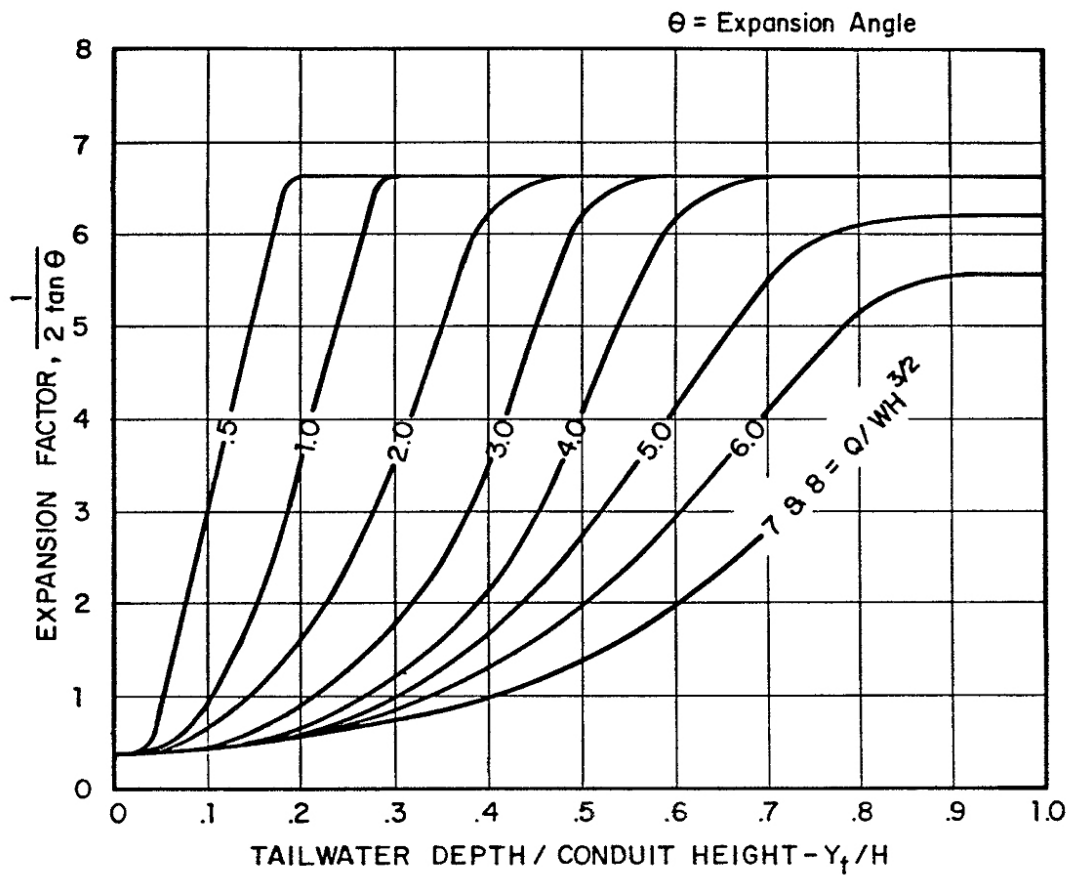


Figure 9-36. Expansion factor for rectangular conduits

### 3.2.2 Low Tailwater Basin

The design of low tailwater riprap basins is necessary when the receiving channel may have little or no flow or tailwater at time when the pipe or culvert is in operation. Figure 9-37 provides a plan and profile view of a typical low tailwater riprap basin.

By providing a low tailwater basin at the end of a storm drain conduit or culvert, the kinetic energy of the discharge dissipates under controlled conditions without causing scour at the channel bottom.

Low tailwater is defined as being equal to or less than  $\frac{1}{3}$  of the height of the storm drain, that is:

$$y_t \leq \frac{D}{3} \quad \text{or} \quad y_t \leq \frac{H}{3}$$

Where:

$y_t$  = tailwater depth at design flow (feet)

$D$  = diameter of circular pipe (feet)

$H$  = height of rectangular pipe (feet)

#### Rock Size

The procedure for determining the required riprap size downstream of a conduit outlet is in Section 3.2.3.

After selecting the riprap size, the minimum thickness of the riprap layer,  $T$ , in feet, in the basin is defined as:

$$T = 2D_{50} \qquad \text{Equation 9-15}$$

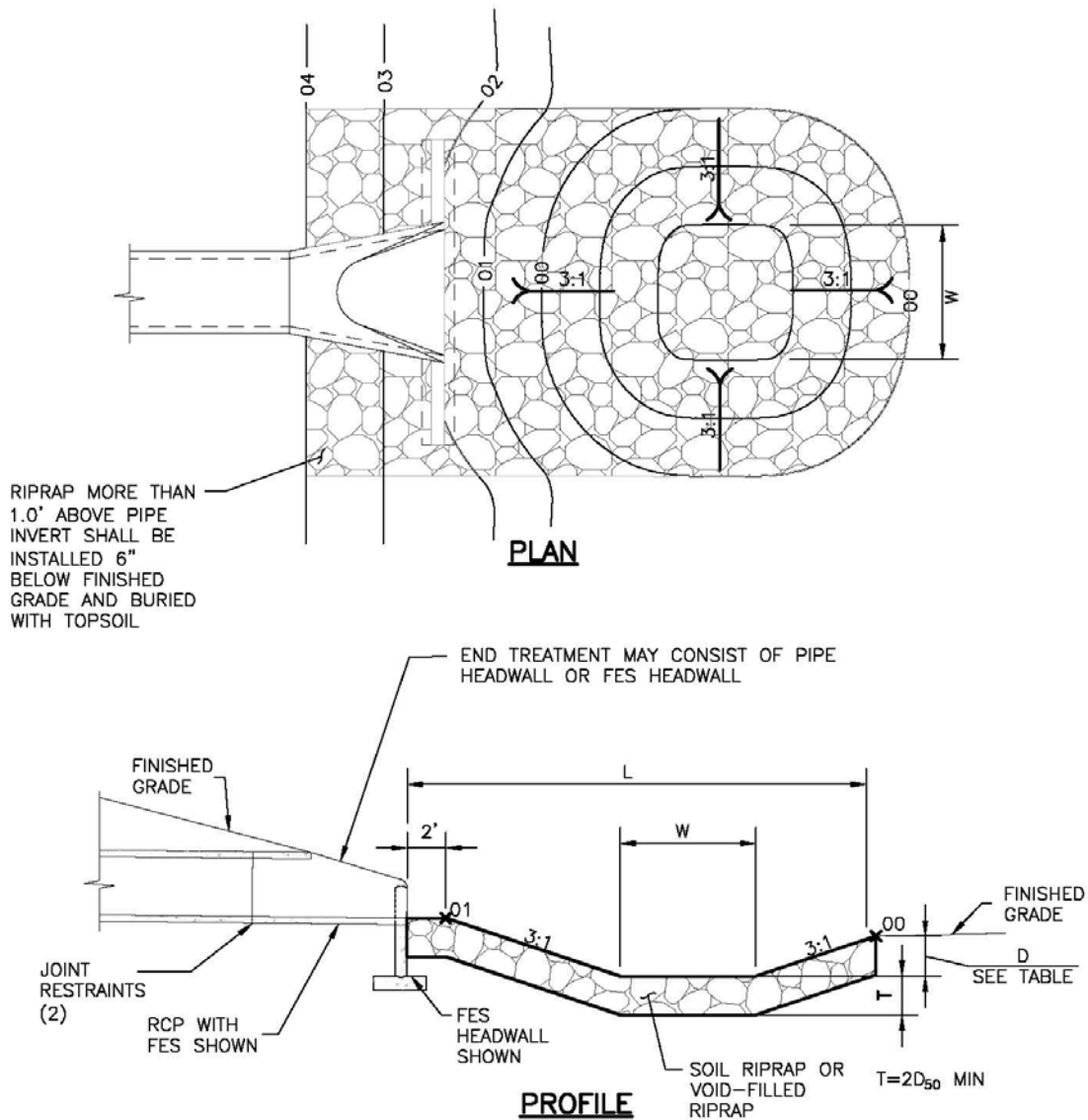
#### Basin Geometry

Figure 9-37 includes a layout of a standard low tailwater riprap basin with the geometry parameters provided. The minimum length of the basin ( $L$ ) and the width of the bottom of the basin ( $W1$ ) are provided in a table at the bottom of Figure 9-37. All slopes in the low tailwater basin shall be 3(H):1(V), minimum.

#### Other Design Requirements

Extend riprap up the outlet embankment slope to the mid-pipe level, minimum. It is recommended that riprap that extends more than 1 foot above the outlet pipe invert be installed 6 inches below finished grade and buried with topsoil.

Provide pipe end treatment in the form of a pipe headwall or a flared-end section headwall. See Section 3.1 for options.



PIPE SIZE OR BOX HEIGHT	D	W*	L
18" - 24"	1'-0"	4'	15'
30" - 36"	1'-6"	6'	20'
42" - 48"	2'-0"	7'	24'
54" - 60"	2'-6"	8'	28'
66" - 72"	3'-0"	9'	32'

\* IF OUTLET PIPE IS A BOX CULVERT WITH A WIDTH GREATER THAN W, THEN W = CULVERT WIDTH

**Figure 9-37. Low tailwater riprap basin**

### 3.2.3 Rock Sizing for Riprap Apron and Low Tailwater Basin

Scour resulting from highly turbulent, rapidly decelerating flow is a common problem at conduit outlets. The following section summarizes the method for sizing riprap protection for both riprap aprons (Section 3.2.1) and low tailwater basins (Section 3.2.2).

Use Figure 9-38 to determine the required rock size for circular conduits and Figure 9-39 for rectangular conduits. Figure 9-38 is valid for  $Q/D_c^{2.5}$  of 6.0 or less and Figure 9-39 is valid for  $Q/WH^{1.5}$  of 8.0 or less. The parameters in these two figures are:

1.  $Q/D^{1.5}$  or  $Q/WH^{0.5}$  in which  $Q$  is the design discharge in cfs,  $D_c$  is the diameter of a circular conduit in feet, and  $W$  and  $H$  are the width and height of a rectangular conduit in feet.
2.  $Y_t/D_c$  or  $Y_t/H$  in which  $Y_t$  is the tailwater depth in feet,  $D_c$  is the diameter of a circular conduit in feet, and  $H$  is the height of a rectangular conduit in feet. In cases where  $Y_t$  is unknown or a hydraulic jump is suspected downstream of the outlet, use  $Y_t/D_t = Y_t/H = 0.40$  when using Figures 9-38 and 9-39.
3. The riprap size requirements in Figures 9-38 and 9-39 are based on the non-dimensional parametric Equations 9-16 and 9-17 (Steven, Simons, and Watts 1971 and Smith 1975).

Circular culvert:

$$d_{50} = \frac{0.023Q}{Y_t^{1.2} D_c^{0.3}} \quad \text{Equation 9-16}$$

Rectangular culvert:

$$d_{50} = \frac{0.014H^{0.5}Q}{Y_t W} \quad \text{Equation 9-17}$$

These rock size requirements assume that the flow in the culvert is subcritical. It is possible to use Equations 9-16 and 9-17 when the flow in the culvert is supercritical (and less than full) if the value of  $D_c$  or  $H$  is modified for use in Figures 9-38 and 9-39. Note that rock sizes referenced in these figures are defined in the *Open Channels* chapter. Whenever the flow is supercritical in the culvert, substitute  $D_a$  for  $D_c$  and  $H_a$  for  $H$ , in which  $D_a$  is defined as:

$$D_a = \frac{(D_c + Y_n)}{2} \quad \text{Equation 9-18}$$

Where the maximum value of  $D_a$  shall not exceed  $D_c$ , and

$$H_a = \frac{(H + Y_n)}{2}$$

Equation 9-19

Where the maximum value of  $H_a$  shall not exceed  $H$ , and:

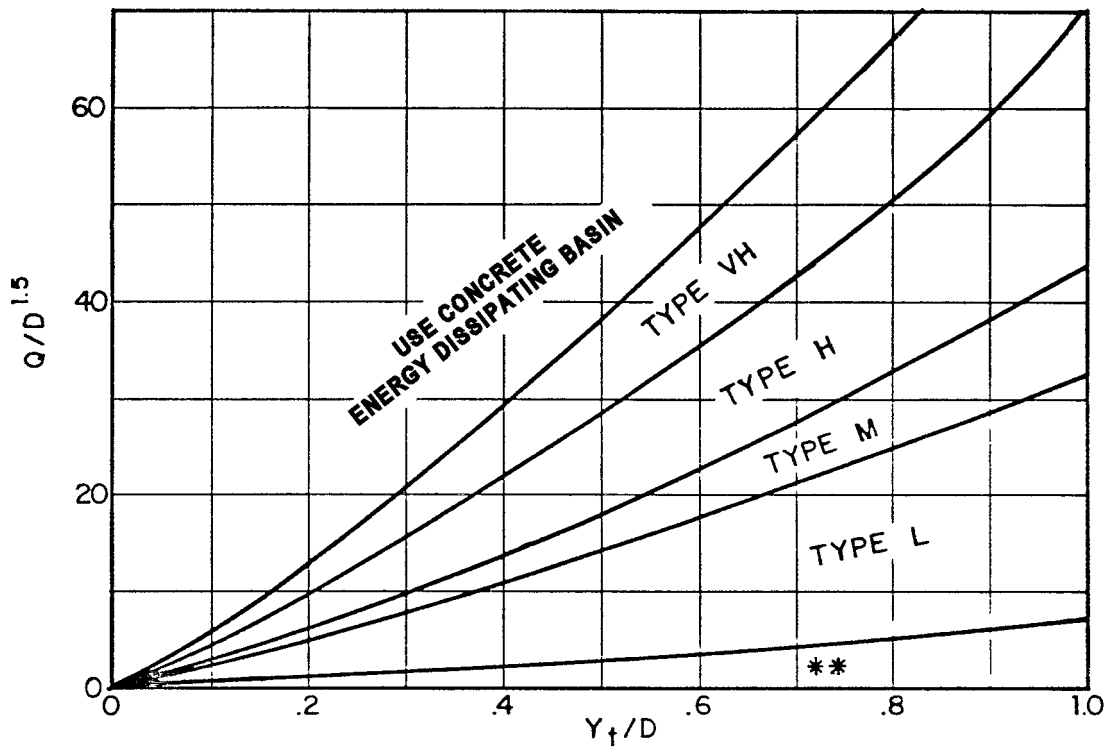
$D_a$  = parameter to use in place of  $D$  in Figure 9-38 when flow is supercritical (ft)

$D_c$  = diameter of circular culvert (ft)

$H_a$  = parameter to use in place of  $H$  in Figure 9-39 when flow is supercritical (ft)

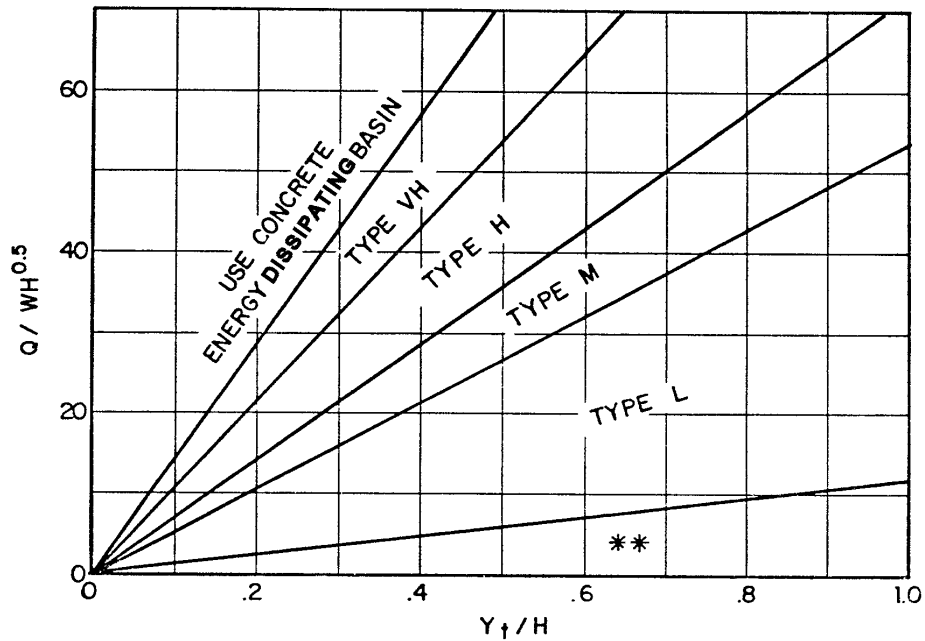
$H$  = height of rectangular culvert (ft)

$Y_n$  = normal depth of supercritical flow in the culvert (ft)



Use  $D_a$  instead of  $D$  whenever flow is supercritical in the barrel.  
 \*\* Use Type L for a distance of  $3D$  downstream.

Figure 9-38. Riprap erosion protection at circular conduit outlet (valid for  $Q/D^{2.5} \leq 6.0$ )



Use  $H_d$  instead of  $H$  whenever culvert has supercritical flow in the barrel.  
 \*\*Use Type L for a distance of  $3H$  downstream.

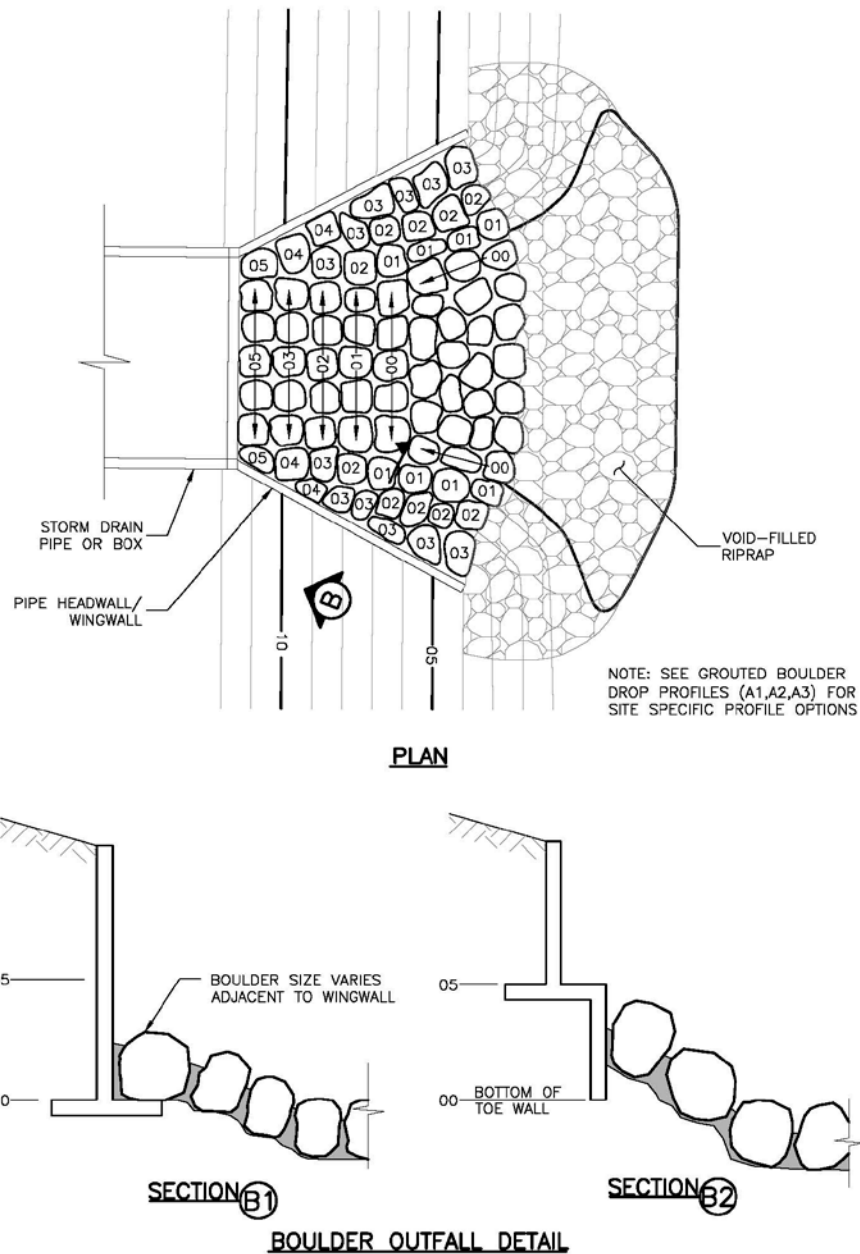
**Figure 9-39. Riprap erosion protection at rectangular conduit outlet (valid for  $Q/WH^{1.5} \leq 8.0$ )**

### 3.2.4 Outfalls and Rundowns

A grouted boulder outfall or “rundown” dissipates energy and provides erosion control protection. Grouted boulder outfalls are most commonly used in large rivers like the South Platte. Figure 9-40 provides a plan view and cross section for a standard grouted boulder rundown. See the grouted boulder drop profiles (A1, A2, and A3) in Figure 9-12 for site specific profile options, (i.e., depressed or free-draining basin for use with a stable downstream channel or with no basin for use in channels subject to degradation). Figure 9-41 provides a plan view of the same structure for use when the structure is in-line with the channel. Evaluate the following when designing a grouted boulder outfall or rundown:

- Minimize disturbance to channel bank
- Determine water surface elevation in receiving channel for base flow and design storm(s)
- Determine flow rate, velocity, depth, etc. of flow exiting the outfall pipe for the design storm(s)
- Evaluate permitting procedures and requirements for construction adjacent to large river system.

Use the criteria presented in Section 2.6 for grouted boulder drop structures as a reference for guidance in the design of a grouted boulder outfall. Those criteria for grout depth, side slopes, and boulder placement also apply to grouted boulder outfalls and rundowns.



**Figure 9-40. Boulder outfall detail**

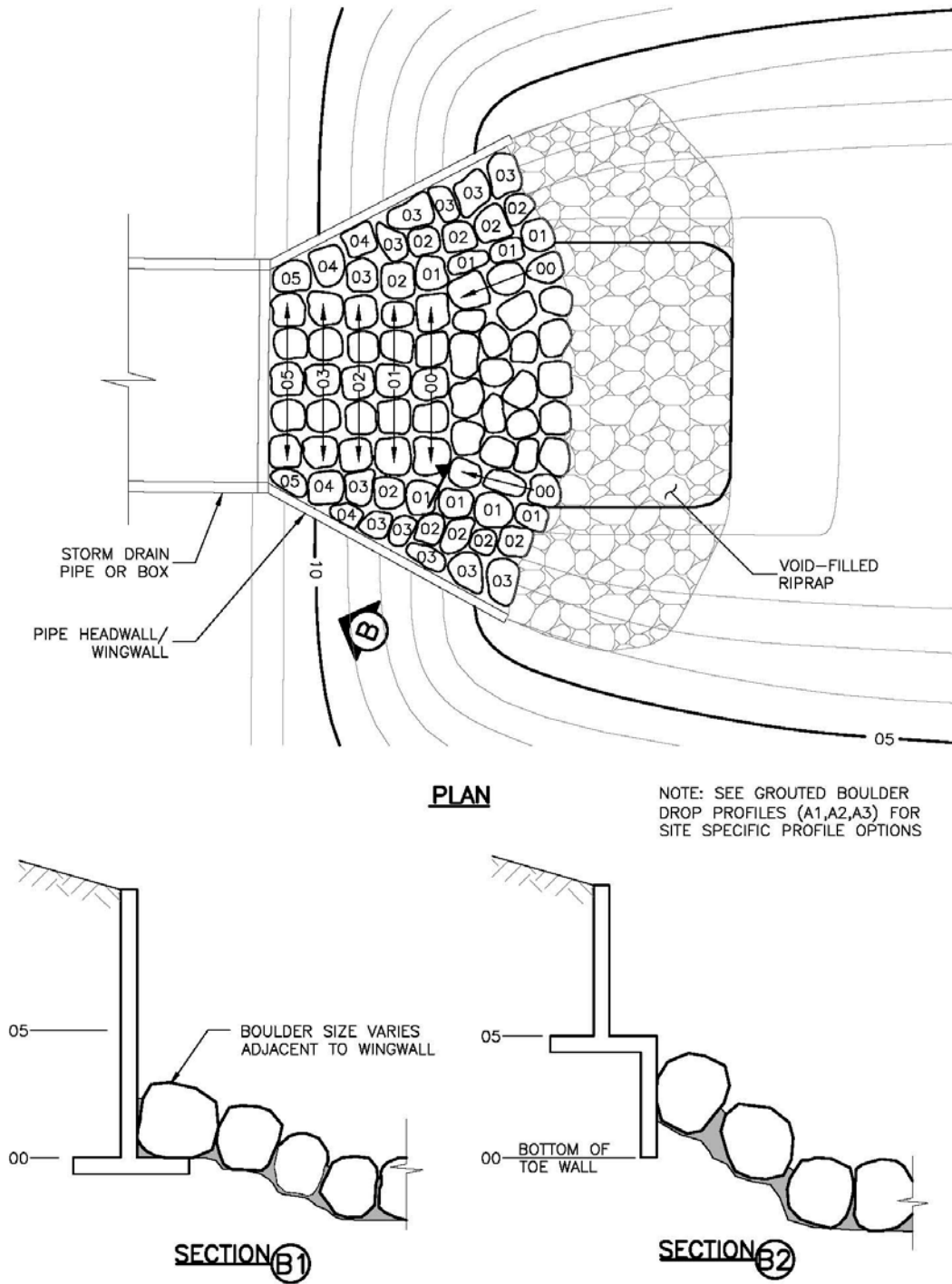


Figure 9-41. Boulder outfall detail (in-line with channel)

Energy dissipation or stilling basin structures are required to minimize scour damages caused by high exit velocities and turbulence at conduit outlets. Outlet structures can provide a high degree of energy dissipation and are generally effective even with relatively low tailwater control. Rock protection at conduit outlets, as discussed in Section 3.2.1, is appropriate where moderate outlet conditions exist; however, there are many situations where rock basins are impractical. Reinforced concrete outlet structures are suitable for a wide variety of site conditions. In some cases, they are more economical than larger rock basins, particularly when long-term costs are considered. The impact basin is an “all-encompassing” structure that does not require a separate design for the pipe end treatment.

Any outlet structure must be designed to match the receiving stream conditions. The following steps include an analysis of the probable range of tailwater and bed conditions that can be anticipated including degradation, aggradation, and local scour.

Use of concrete is often more economical due to structure size or local availability of materials. Initial design selection should include consideration of a conduit outlet structure if any of the following situations exist:

- High-energy dissipation efficiency is required, where hydraulic conditions approach or exceed the limits for alternate designs (see the *Open Channels* chapter);
- Low tailwater control is anticipated; or
- Site conditions, such as public use areas, where plunge pools and standing water are unacceptable because of safety and appearance, or at locations where space limitations direct the use of a concrete structure.

#### **Impact Basins for Small Outlets**

Figures 9-43 and 9-44 provide design layout for circular outlets up to 48 inches in diameter. Unlike the Type VI impact basin used for large outlets, the modified basin does not require sizing for flow under velocities recommended in the *Streets, Inlets, and Storm Drains* chapter. However, use of this detail is limited to exit velocities of 18 feet per second or less. For larger conduits and higher exit velocities, use the Type VI impact basin.

#### **Impact Basins for Large Outlets**

Conduits with large cross-sectional areas are for significant discharges and often with high velocities requiring special hydraulic design at their outlets. Here, dam outlet and spillway terminal structure technology is appropriate (USBR 1987). Type II, III or VI (USBR nomenclature) stilling basins, submerged bucket with plunge basin energy dissipators and slotted-grating dissipators can be considered when appropriate to the site conditions. For instance, a plunge basin may have applicability where discharge is to a retention pond or a lake. Alternate designs of pipe exit energy dissipators provided in this chapter can be matched to a variety of pipe sizes, pipe outlet physical configurations, and hydraulic conditions.

Most design standards for an impact stilling basin are based on the USBR Type VI basin, often called “impact dissipater” or conduit “outlet stilling basin.” This basin is a relatively small structure that is very efficient in dissipating energy without the need of tailwater. The original hydraulic design reference (Biechley 1971) is based on model studies. Additional structural design details are provided by Aisenbrey, et al. 1974; and Peterka 1984.

The Type VI basin was originally designed to operate continuously at the design flow rate. However, it is applicable for use under the varied flow conditions of stormwater runoff. The USBR Type VI Impact Basin design configuration is shown in Figure 9-43, which consists of an open concrete box attached directly to the conduit outlet. The width,  $W$ , is a function of the Froude number and can be determined using Figure 9-46. The sidewalls are high enough to contain most of the splashing during high flows and slope down to form a transition to the receiving channel. The inlet pipe is vertically aligned with an overhanging L-shaped baffle such that the pipe invert is not lower than the bottom of the baffle. The end check height is equal to the height under the baffle to produce tailwater in the basin. UDFCD modified this USBR structure to provide a means of draining the structure to improve maintenance conditions and avoid development of mosquito habitat. Low-flow modifications have not been fully tested to date. Avoid compromising the overall hydraulic performance of the structure.

### Multiple Conduit Entry to an Impact Basin

Where two or more conduits of different sizes outlet in close proximity to each other, a composite structure can be constructed to eliminate common walls. This can be somewhat awkward since each basin “cell” must be designed as an individual basin with different height, width, etc. Where feasible, a more economical approach is to combine storm drains at a manhole or vault and bring a single, combined pipe to the outlet structure.

When using the modified Type VI impact basin for two side-by-side pipes of the same size, the two pipes may discharge into a single basin. In this scenario, increase the width of the basin by a factor of 1.5.

When the flow is different for the two conduits, the width of the basin is based on the pipe carrying the higher flow. For the modified impact basin shown in 9-43, add  $1/2 D$  space between the pipes and to each outside pipe edge when two pipes discharge into the basin to determine the width of the headwall and extent the width of the impact wall to match the outside edges of the two pipes. The effect of mixing and turbulence of the combined flows in the basin was not modeled.

The remaining structure dimensions are based on the design width of a separate basin  $W$ . If the two pipes have different flow, the combined structure is based on the higher Froude number. Install handrails, access control grating, or a hinged rack around the open basin areas where safety is a concern.

### General Design Procedure for Type VI Impact Basin

1. Calculate the Froude number. Determine the design hydraulic cross-sectional area inside the pipe at the outlet. Determine the effective flow velocity,  $V$ , at the same location in the pipe. Assume the depth of flow ( $D$ ), is equal to the square root of the flow area inside the pipe at the outlet.

$$\text{Froude number} = \frac{V}{(gD)^{1/2}}$$

2. Place the entrance pipe horizontally at least one pipe diameter equivalent length upstream from the outlet. For pipe slopes greater than 15 degrees, the horizontal length should be a minimum of two pipe diameters.
3. Determine the basin width,  $W$ , by entering the Froude number and effective flow depth into Figure 9-40. The remaining dimensions are proportional to the basin width according to Figure 9-39. Do not oversize the basin width. Larger basins become less effective as the inflow can pass under the baffle.

4. Design structure wall thickness, steel reinforcement, and anchor walls (underneath the floor) using accepted structural engineering methods. Note the baffle thickness,  $t_b$ , is a suggested minimum. It is not a hydraulic parameter and is not a substitute for structural analysis. Hydraulic forces on the overhanging baffle may be approximated by determining the hydraulic jet force at the outlet:

$$F_j = 1.94 V_{out} Q \text{ (force in pounds)} \quad \text{Equation 9-20}$$

$Q$  = maximum design discharge (cfs)  
 $V_{out}$  = velocity of the outlet jet (ft/sec)

Provide type “M” soil riprap or void-filled riprap in the receiving channel from the end check to a minimum distance equal to the basin width.

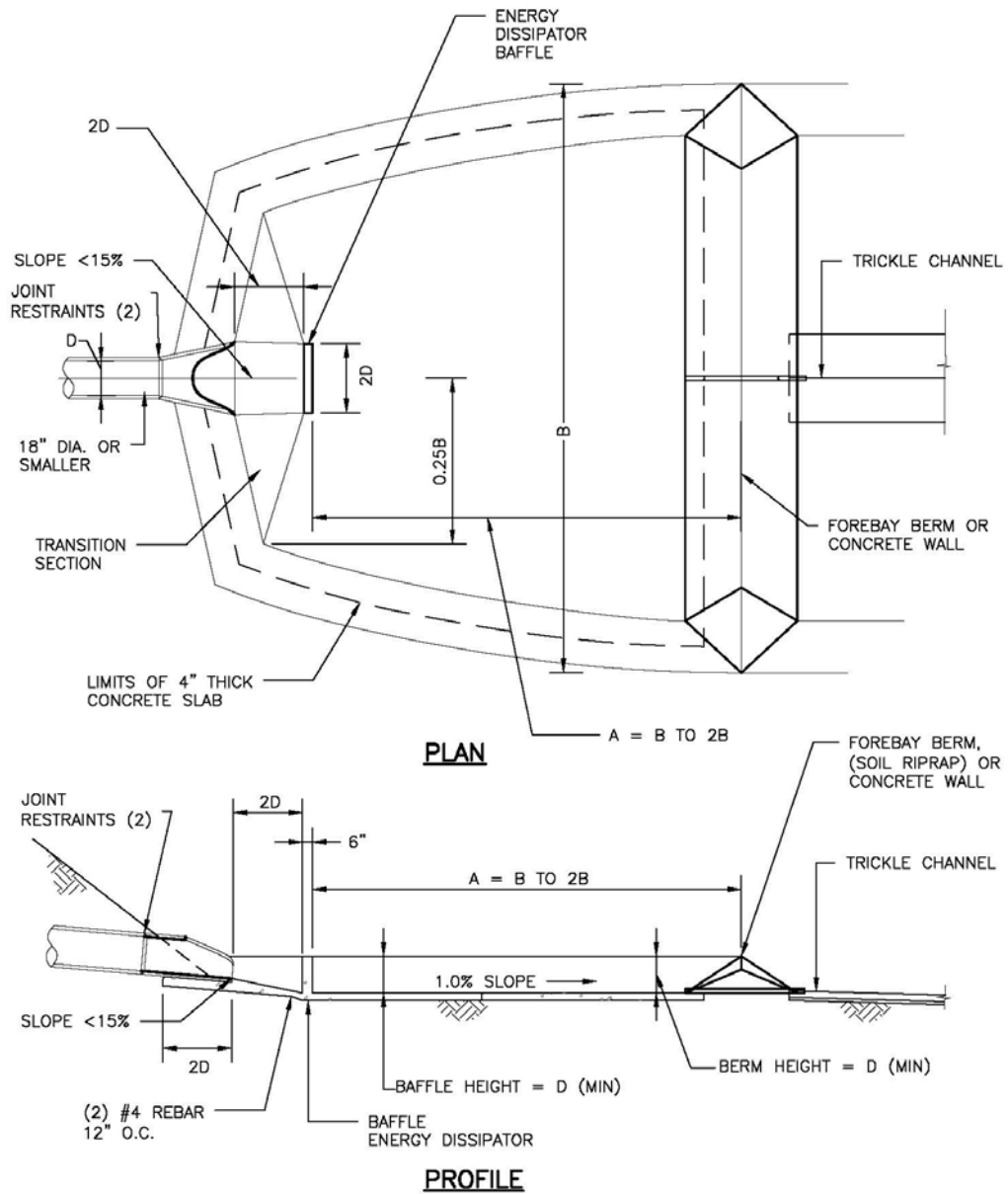


Figure 9-42. Impact stilling basin for pipes smaller than 18" in diameter

(Source: City and County of Denver 2006)

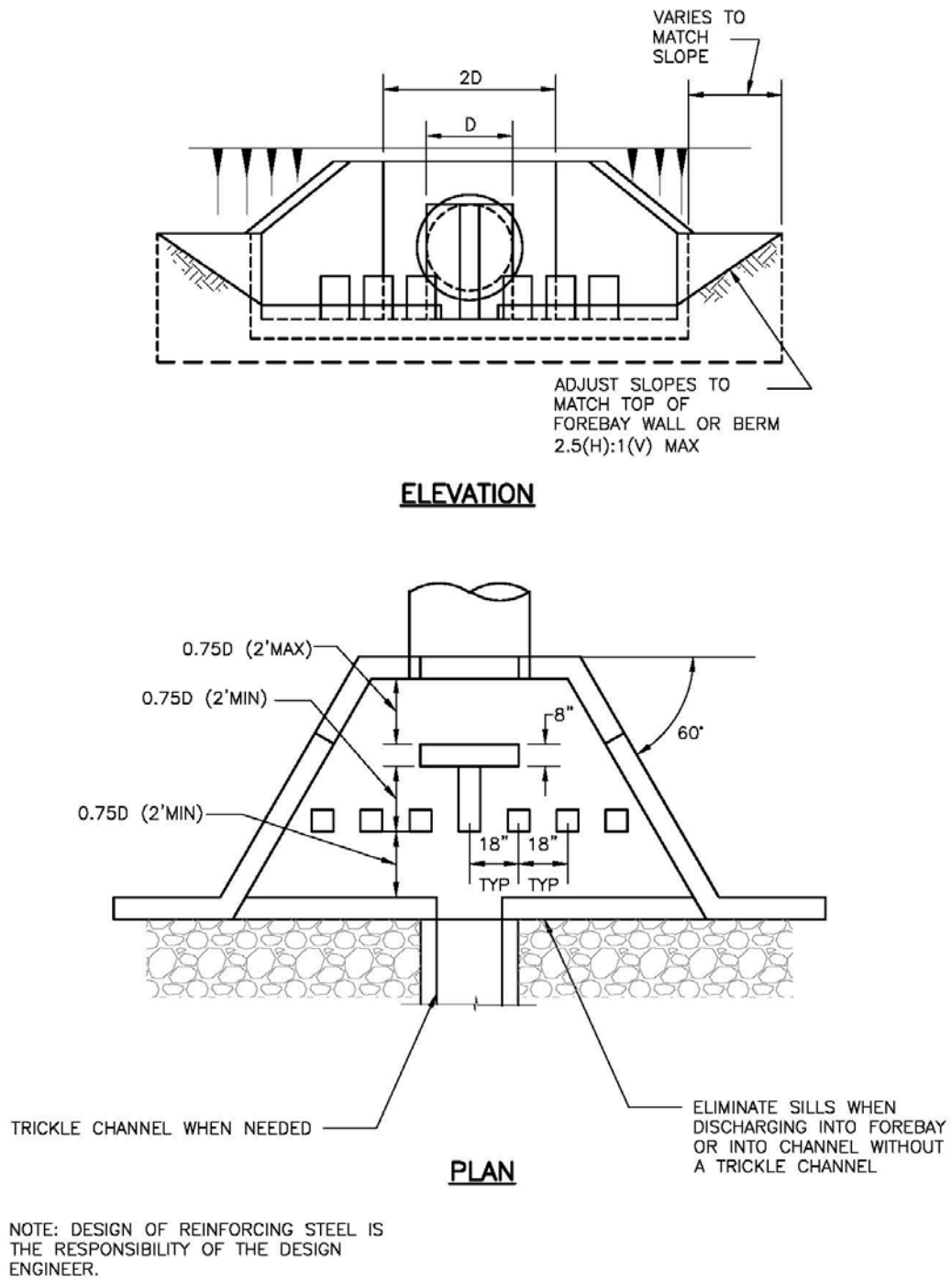


Figure 9-43. Modified impact stilling basin for conduits 18'' to 48'' in diameter (Part 1 of 2)

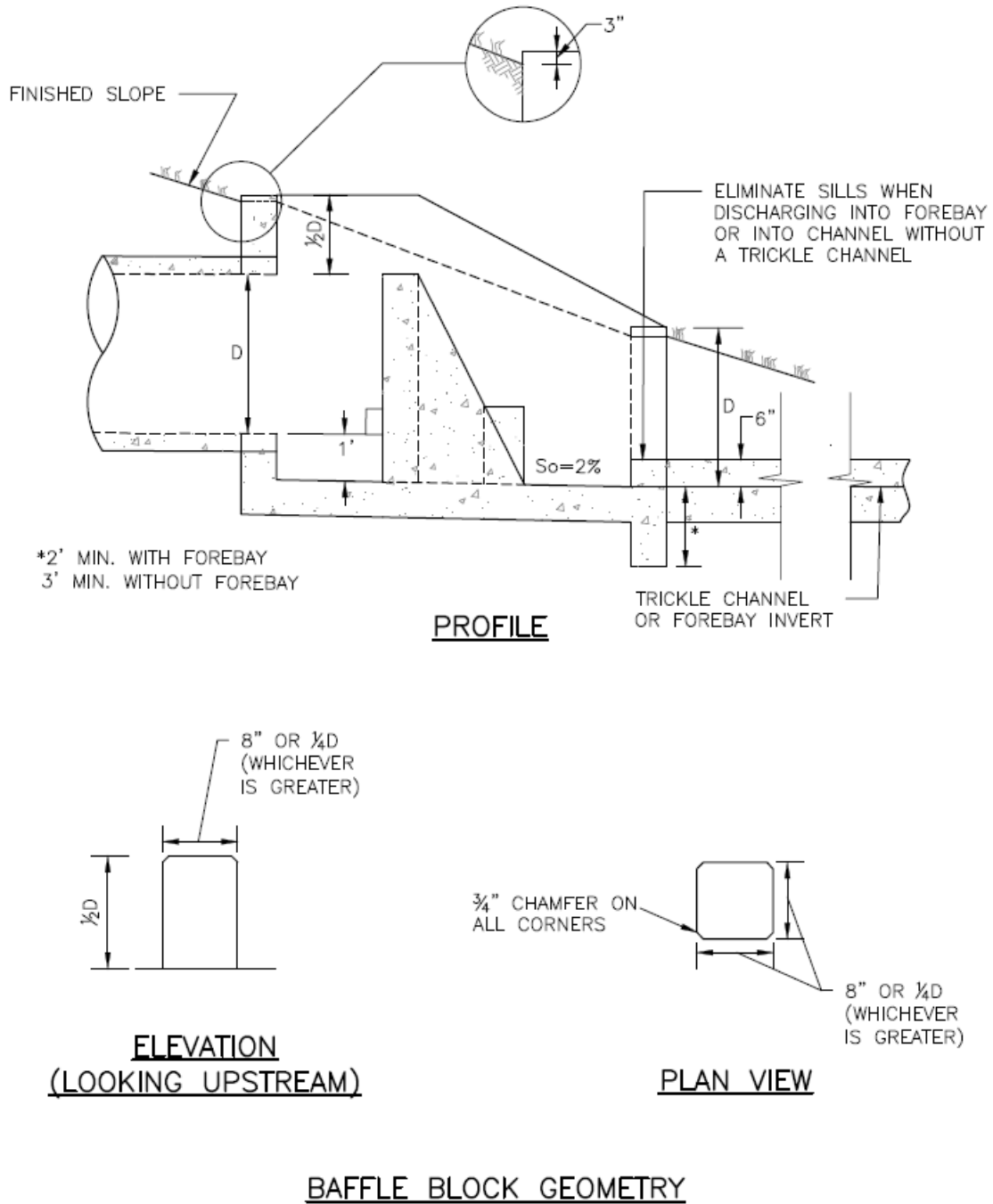


Figure 9-44. Modified impact stilling basin for conduits 18" to 48" in diameter (Part 2 of 2)

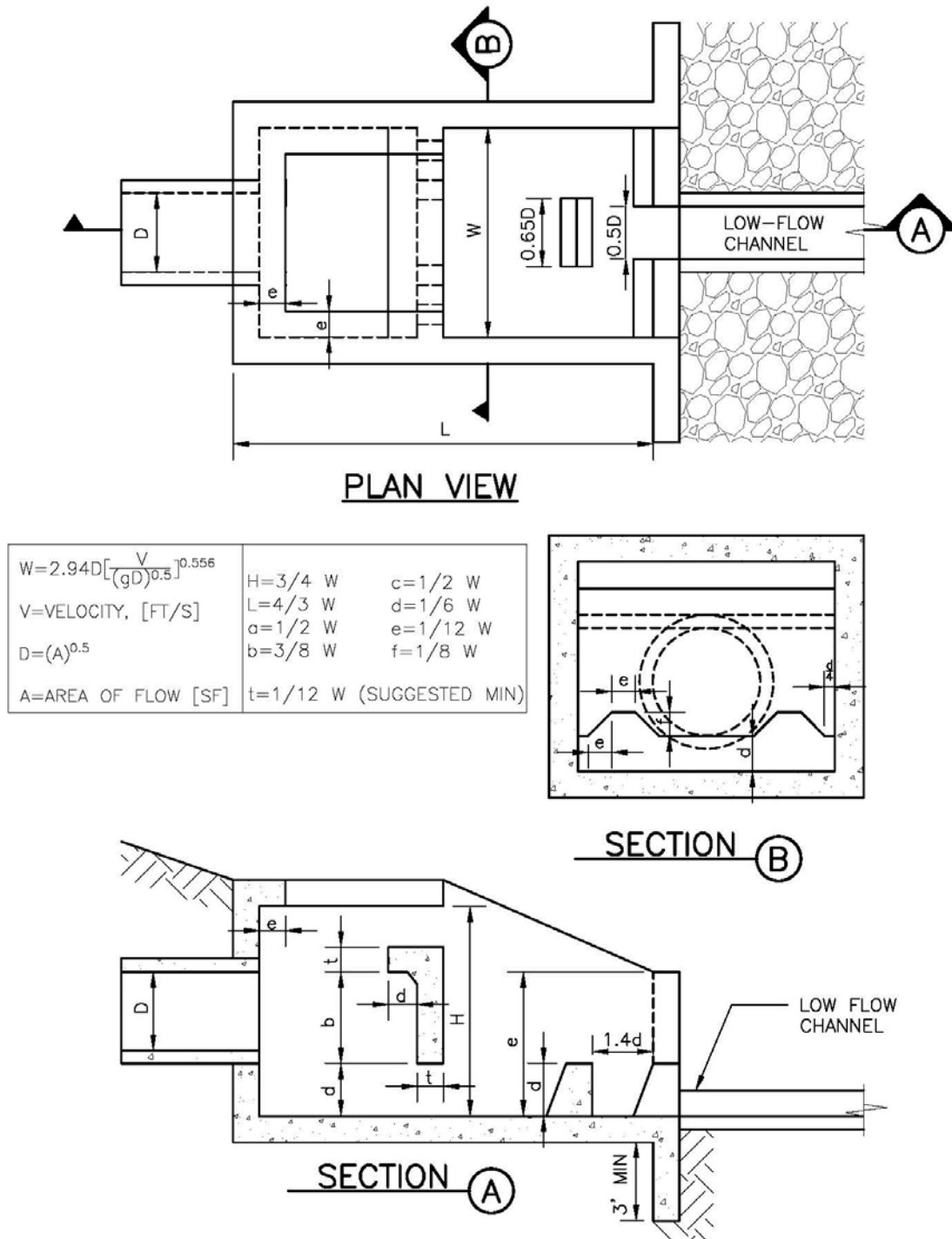
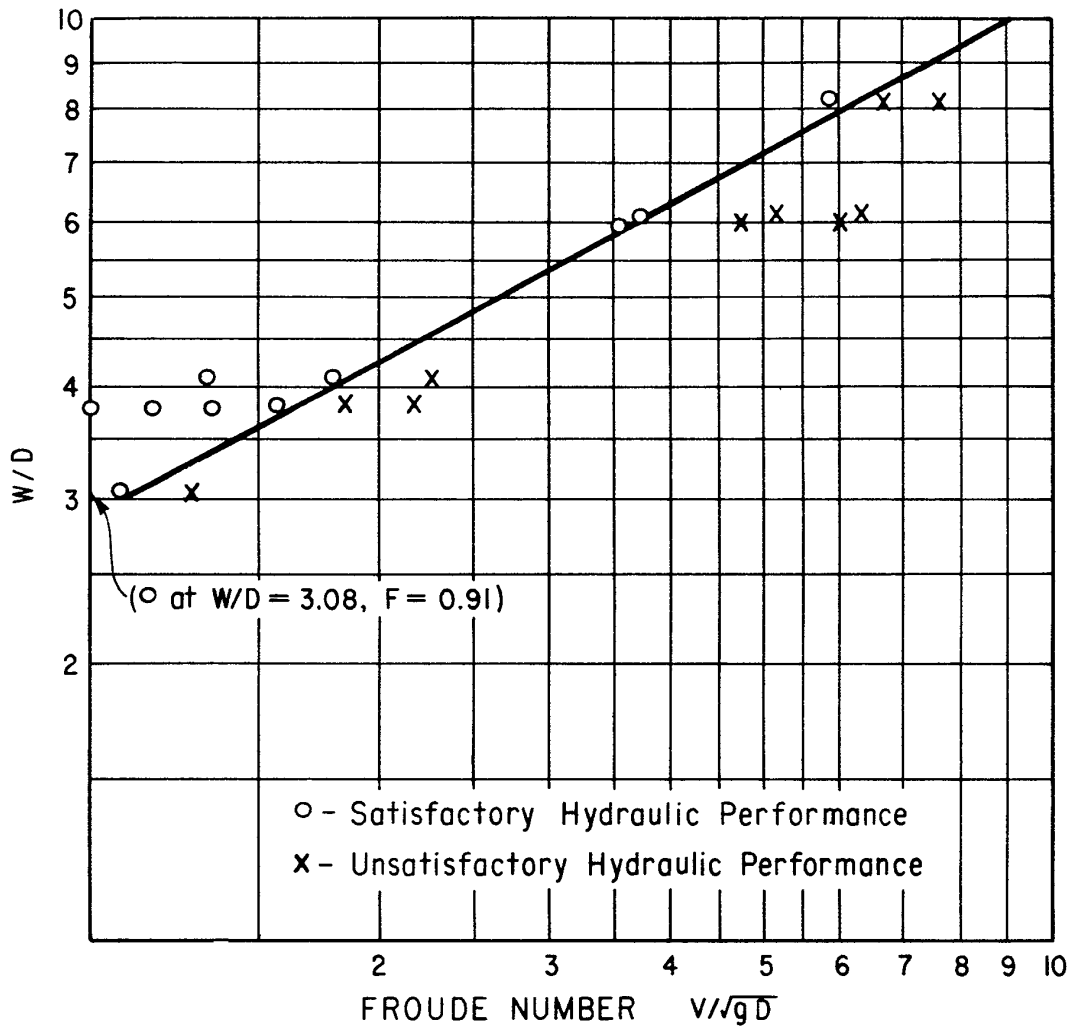


Figure 9-45. UDFCD modified USBR type VI impacts stilling basin (general design dimensions)



"W" is the inside width of the basin.  
 "D" represents the depth of flow entering the basin and is the square root of the flow area at the conduit outlet.  
 "V" is the velocity of the incoming flow.  
 The tailwater depth is uncontrolled.

Figure 9-46. Basin width diagram for the USBR type VI impact stilling basin

### 3.2.5 Rundowns

Rundowns are used to convey storm runoff from the bank of a channel to the invert of an open channel. Rundowns can also convey runoff from streets and parking lots into channels or storage facilities. The use of rundowns is discouraged due to their high rate of failure and resulting unsightly structures that become a maintenance burden. The preferred alternative is to spread flows over the embankment using a level spreader. See the Grass Buffer Fact Sheet located in Chapter 4 of Volume 3 for guidance on level spreaders. If the flow is too great to be distributed and conveyed down the slope of an open channel, use a pipe to convey flows closer to the invert of the stream or use a drop structure. For both of these options, provide adequate erosion protection at the downstream end.

In the case when a rundown is the only viable option, use the following design criteria.

#### **Design Flow**

The rundown should be designed to carry the full design flow of the tributary area upstream (see *Runoff* chapter), or 1 cfs (assuming critical depth) with freeboard, whichever is greater.

#### **Cross Section**

Construct the rundown with grouted boulder invert and edge treatment. The top of edge treatment should be flush with proposed grade. Ensure a minimum of 1 foot of freeboard from the calculated design flow depth from the invert to the top of the grouted boulders. Do not use riprap or soil riprap rundowns as they frequently fail.

## 4.0 References

- Abt, S.R., J.R. Ruff, R.J. Wittler and D.L. LaGrone. 1987. *Gradation and Layer Thickness Effects on Riprap*. ASCE National Conference on Hydraulic Engineering. New York: ASCE.
- Abt, S.R., J.R. Ruff, R.J. Wittler and D.L. LaGrone. 1986. *Environmental Assessment of Uranium Recovery Activities—Riprap Testing*. Phase I. Oak Ridge, TN: Oak Ridge National Laboratory.
- Aisenbrey, A.J., R.B. Hayes, J.H. Warren, D.L. Winsett and R.G. Young. 1978. *Design of Small Canal Structures*. Washington, DC: U.S. Department of the Interior, Bureau of Reclamation.
- American Association of State Highway and Transportation Officials (AASHTO) Task Force on Hydrology and Hydraulics, Highway Subcommittee on Design. 1987. *Hydraulic Analysis. Location and Design of Bridges*. Washington, DC: AASHTO.
- American Society of Civil Engineers and Water Environment Federation (ASCE and WEF). 1992. *Design and Construction of Urban Stormwater Management Systems*. American Society of Civil Engineers Manuals and Reports of Engineering Practice No. 77 and Water Environment Federation Manual of Practice FD-20. New York: ASCE.
- Anderson, A.G., A.S. Paintal, and J.T. Davenport. 1968. *Tentative Design Procedure for Riprap Lined Channels*. Project Design Report No. 96. Minneapolis, MN: St. Anthony Falls Hydraulic Laboratory, University of Minnesota.
- Anderson, A.G. 1973. *Tentative Design Procedure for Riprap Lined Channels—Field Evaluation*. University of Minnesota, St. Anthony Falls Hydraulic Laboratory, Project Report No. 146 Prepared for Highway Research Board. Washington, DC: National Academy Press.
- Barnes, H.H. 1967. *Roughness Characteristics of Natural Channels*. Water Supply Paper No. 1849. Washington, DC: U.S. Department of the Interior, Geological Survey.
- Bathurst, J.C., R.M. Li, and D.B. Simons. 1979. *Hydraulics of Mountain Rivers*. Ft. Collins, CO: Civil Engineering Department, Colorado State University.
- Bechdel, L. and S. Ray. 1997. *River Rescue, A Manual for Whitewater Safety*. Boston, MA: Appalachian Mountain Club Books.
- Behlke, C.E., and H.D. Pritchett. 1966. *The Design of Supercritical Flow Channel Junctions*. Highway Research Record. Washington, DC: National Academy of Sciences.
- Beichley, G.L. 1971. *Hydraulic Design of Stilling Basin for Pipe or Channel Outlets*. Research Report No. 24. Washington, DC: U.S. Department of the Interior, Bureau of Reclamation.
- Bethlehem Steel Corporation. 1959. *Solving Drainage Problems*. Bethlehem, PA: Bethlehem Steel Corporation.
- Blaisdell, F.W. 1949. *The SAF Stilling Design*. Washington, DC: U.S. Department of Agriculture, Soil Conservation Service.
- Blaisdell, F.W., and C.L. Anderson. 1984. *Pipe Spillway Plunge Pool Design Equations*. Water for Resource Development, D.L. Schreiber ed. New York: ASCE.

- Borland-Coogan Associates, Inc. 1980. *The Drowning Machine*. s.l.: Borland-Coogan Associates.
- Bowers, C.E. 1950. Hydraulic Model Studies for Whiting Field Naval Air Station, Part V. In *Studies of Open-Channel Junctions*. Project Report No. 24. Minneapolis, MN: St Anthony Falls Hydraulic Laboratory, University of Minnesota.
- Bowers, C.E. and J.W. Toso. 1988. Karnafuli Project, Model Studies of Spillway Damage. *Journal of Hydraulic Engineering* 114(5)469-483.
- Canada Department of Agriculture. 1951. *Report on Steel Sheet Piling Studies*. Saskatoon SK: Soil Mechanics and Materials Division, Canada Department of Agriculture.
- Cedergren, H.R. 1967. *Seepage Drainage and Flow Nets*. New York: John Wiley and Sons.
- Chee, S.P. 1983. Riverbed Degradation Due to Plunging Streams. In *Symposium of Erosion and Sedimentation*, Ruh-Ming Li, and Peter F. Lagasse, eds. Ft. Collins, CO: Simons, Li and Assoc.
- Chen, Y.H. 1985. Embankment Overtopping Tests to Evaluate Damage. In *Hydraulics and Hydrology in the Small Computer Age, Volume 2*, W.R. Waldrop, ed. Ft. Collins, CO: Simons, Li and Associates Inc.
- Chow, V.T. 1959. *Open-Channel Hydraulics*. New York: McGraw-Hill Book Company.
- Corry, M.L., P.L. Thompson, F.J. Watts, J.S. Jones, and D.L. Richards. 1975. *The Hydraulic Design of Energy Dissipators for Culverts and Channels*. Hydraulic Engineering Circular No. 14. Washington, DC: Federal Highway Administration.
- Cotton, G.K. 1995. Hazard Rating for Low Drops. In *Water Resources Engineering*, W.H. Espey, Jr. and P.G. Combs eds., 1111-1115. New York: ASCE.
- D'Appalonia, D.J. 1980. Soil Bentonite Slurry Trench Cutoffs. *Journal of the Geotechnical Engineering Division* 106(4)395-417.
- Davis, D.W. and M.W. Burnham. 1987. Accuracy of Computed Water Surface Profiles. In *Hydraulic Engineering—1987*, R.M. Raguean, ed. 818-823. New York: ASCE.
- Donald H. Godi and Associates, Inc. 1984. *Guidelines for Development and Maintenance of Natural Vegetation*. Denver, CO: Urban Drainage and Flood Control District.
- Forster, J.W. and R.A. Skringde. 1950. *Control of the Hydraulic Jump by Sills*. American Society of Civil Engineers Transactions 115, 973-987.
- Henderson, R.M. 1966. *Open Channel Flow*. New York: Macmillan Company.
- Hsu, En-Yun. 1950. *Discussion on Control of the Hydraulic Jump by Sills, by Forester and Skindge*. American Society of Civil Engineers Transactions Vol. 115, 988-991.
- Hughes, W.C. 1976. *Rock and Riprap Design Manual for Channel Erosion Protection*. Boulder, CO: University of Colorado.
- Ippen, A.T. 1951. *Mechanics of Supercritical Flows in High Velocity Flow Open Channels*. American Society of Civil Engineers Transactions 116, 268-295.

- Isbash, S.V. 1936. Construction of Dams by Depositing Rock in Running Water. *Transactions, Second Congress on Large Dams*. Washington DC: *s.n.*
- Jansen, R.B. 1980. *Dams and Public Safety*. Washington, DC: U.S. Department of the Interior, Water and Power Resources Service.
- Kindsvatter, C.E., R.W. Carter, and H.J. Tracy. 1953. *Computation of Peak Discharge at Contractions*. US Geological Survey Circular 284. Washington, DC: U.S. Geological Survey.
- Knapp, R.T. 1951. "Design of Channel Curves for Supercritical Flow." In *High-Velocity Flow Open Channels*. American Society of Civil Engineers Transactions 116, 296-325.
- Lane, E.W. 1935. "Security from Under Seepage Masonry Dams on Earth Foundations." *American Society of Civil Engineers Transactions* 100, 1235-1272.
- Lane, K.S. and P.E. Wolt. 1961. *Performance of Sheet Piling and Blankets for Sealing Missouri River Reservoirs*. In Proceedings, Seventh Congress on Large Dams, 255-279. *s.l.: s.n.*
- Lederle Consulting Engineers. 1985. *West Harvard Gulch Rehabilitative Improvements, Engineering Report on Drop Structure Alternatives*. Denver, CO: Urban Drainage and Flood Control District.
- Leutheusser, H. and W. Birk. 1991. "Drownproofing of Low Overflow Structures". *J. Hydraulics Division*. 117(HY2)205-213.
- Li Simons and Associates. 1981. *Design Guidelines and Criteria for Channels and Hydraulic Structures on Sandy Soils*. Denver, CO: Urban Drainage and Flood Control District.
- Li Simons and Associates. 1982. *Engineering Analysis of Fluvial Systems*. Chelsea, MI: Book Crafters.
- Li Simons and Associates. 1982. *Surface Mining Water Diversion Design Manual*. Washington, DC: Office of Surface Mining.
- Li Simons and Associates. 1985. *Design Manual for Engineering Analysis of Fluvial Systems*. Phoenix, AZ: Arizona Department of Water Resources.
- Li Simons and Associates. 1986. *Project Report Hydraulic Model Study of Local Scour Downstream of Rigid Grade Control Structures*. Tucson, AZ: Pima County Department of Transportation and Flood Control District.
- Li Simons and Associates. 1989. *Sizing Riprap for the Protection of Approach Embankments and Spur Pikes—Limiting the Depth of Scour at Bridge Piers and Abutments*. Phoenix, AZ: Arizona Department of Transportation.
- Linder, W.M. 1963. "Stabilization of Streambeds with Sheet Piling and Rock Sills." *Proceedings of the Federal Inter-Agency Sedimentation Conference*. Washington, DC: U.S. Department of Agriculture.
- Little, W.C. and J.B. Murphey. 1982. "Model Study of Low Drop Grade Control Structures." *Journal of Hydraulics Division* 108(HY10).
- Little, W.C. and R.C. Daniel. 1981. *Design and Construction of Low Drop Structures*. Applying Research To Hydraulic Practice, P.E. Smith, ed., 21-31. New York: ASCE.

- Maynard, S.T. 1978. *Practical Riprap Design*. Miscellaneous Paper H-78-7. Washington, DC: U.S. Army, Corps of Engineers.
- Maynard, T. and J.F. Ruff. 1987. "Riprap Stability on Channel Side Slopes." *ASCE National Conference on Hydraulic Engineering*. New York: ASCE.
- McDonald, M.G. and A.W. Harbaugh. 1989. *A Modular Three-Dimensional Finite Difference Groundwater Flow Model*. Open File Report 83-875. Denver, CO: U.S. Geological Survey.
- McLaughlin Water Engineers, Ltd. (MWE). 1986. *Evaluation of and Recommendations for Drop Structures in the Denver Metropolitan Area*. Denver, CO: Urban Drainage and Flood Control District.
- Miller, S.P., Hon-Yim Ko, and J. Dunn. 1985. "Embankment Overtopping." *Hydraulics and Hydrology in the Small Computer Age, Volume 2*, W.R. Waldrop, ed. Ft. Collins, CO: Simons, Li and Associates Inc.
- Millet, R.A. and J. Yves-Perez. 1981. *Current USA Practice: Slurry Wall Specification*. Journal of the Geotechnical Engineering Division 107, 1041-1055.
- Morgenstern, N. and I. Amir-Tahmasseb. 1985. *The Stability of a Slurry Trench in Cohesionless Soils*. *Geotechnique* 15, 387-395, 1965.
- Moses, T. and Lower, M. 2003. "Natural Channel Design of Step-Pool Watercourses Using the "Keystone" Concept." *World Water and Environmental Resources Congress 2003: pp.1-11*.
- Muller Engineering Co. 1980. *Drop Structure Procedure*. Denver, CO: Urban Drainage and Flood Control District.
- Mussetter, R.A. 1983. "Equilibrium Slopes above Channel Control Structures." *Symposium on Erosion and Sedimentation, Ruh-Ming Li and P.F. Lagasse, eds*. Ft. Collins, CO: Li Simons and Associates, Inc.
- Myers, C.T. 1982. *Rock Riprap Gradient Control Structures*. Applying Research to Hydraulic Practice, P.E. Smith, ed., 10-20. New York: ASCE.
- Neuman, S.P. and P.A. Witherspoon. 1970. *Finite Element Method of Analyzing Steady Seepage with a Free Surface*. Water Resources Research 6(3)889-897.
- Olivier, H. 1967. "Through and Overflow Rockfill Dams—New Design Techniques." *Journal of the Institute of Civil Engineering*, Paper No. 7012.
- Pemberton, E.L. and J.M. Lara. 1984. *Computing Degradation and Local Scour*. Denver, CO: U.S. Bureau of Reclamation.
- Peterka, A.J. 1984. *Hydraulic Design of Stilling Basins and Energy Dissipators*. Engineering Monograph No. 25. Washington, DC: U.S. Bureau of Reclamation.
- Portland Cement Association. 1964. *Handbook of Concrete Culvert Pipe Hydraulics*. Chicago, IL: Portland Cement Association.
- Posey, C. J. 1955. "Flood-Erosion Protection for Highway Fills, with discussion by Messrs. Gerald H. Matthes, Emory W. Lane, Carl F. Izzard, Joseph N. Bradley, Carl E. Kindsvater, and Parley R. Nutey, and Chesley A. Posey." *American Society of Civil Engineers Transactions*.

- Powledge, G.R. and R.A. Dodge. 1985. "Overtopping of Small Dams—an Alternative for Dam Safety." In *Hydraulics and Hydrology in the Small Computer Age*, Volume 2, W.R. Waldrop, ed. Ft. Collins, CO: Simons, Li and Associates Inc.
- Reese, A.J. 1984. "Riprap Sizing—Four Methods." *J. Water for Res. Development*. New York: ASCE.
- Reese, A.J. 1986. *Nomographic Riprap Design*. Vicksburg, MS: Hydraulics Laboratory, U.S. Army Corps of Engineers.
- Reeves, G.N. 1985. *Planned Overtopping of Embankments Using Roller Compacted Concrete*. In *Hydraulics and Hydrology in the Small Computer Age*, Volume 2, W.R. Waldrop, ed. Ft. Collins, CO: Simons, Li and Associates Inc.
- Rhone, T.J. 1977. "Baffled Apron as Spillway Energy Dissipator." *Journal of the Hydraulics Division* 103(12)1391-1401.
- Richardson, E.V. 1974. *Highways in the River Environment*. Washington, DC: U. S. Department of Transportation, Federal Highway Administration.
- Richardson, E.V. 1988. *Highways in the River Environment*. Washington, DC: U. S. Department of Transportation, Federal Highway Administration.
- Rouse, H. 1949. *Engineering Hydraulics*. Proceedings of the Fourth Hydraulics Conference, Iowa Institute of Hydraulic Research. New York: John Wiley and Sons, Inc.
- Rushton, K.R., and S.C. Redshaw. 1979. *Seepage and Groundwater Flow Numerical Analysis by Analog and Digital Methods*. New York: John Wiley and Sons, Inc.
- Sabol, G.V, and R.J. Martinek. 1982. *Energy Grade/Grade Control Structures for Steep Channels, Phase II*. Albuquerque, NM: Albuquerque Metropolitan Arroyo Flood Control Authority and City of Albuquerque.
- Samad, M.A. 1978. *Analysis of Riprap for Channel Stabilization*. Ph.D. Dissertation, Department of Civil Engineering, Colorado State University.
- Samad, M.A., J.P. Pflaum, W.C. Taggart, and R.E. McLaughlin. 1986. *Modeling of the Undular Jump for White River Bypass*. Water Forum '86: World Water Issues in Evolution, Volume 1, M. Karamoutz, G.R. Baumli and W.J. Brich, eds.
- Sandover, J.A. and P. Holmes. 1962. *Hydraulic Jump in Trapezoidal Channels*. Water Power. s.l.: s.n.
- Shen, H.W., ed. 1971. *River Mechanics, Vol. I and II*. Ft. Collins, CO: Colorado State University.
- Shields, F.D. Jr. 1982. *Environmental Features for Flood Control Channels*. Water Res. Bulletin 18(5).
- Simons, D.B. 1983. *Symposium on Erosion and Sedimentation*. Ft. Collins, CO: Simons, Li and Associates Inc.
- Simons, D.B. and F. Sentark. 1977. *Sediment Transport Technology*. Ft. Collins, CO: Water Res. Publications.
- Smith, C.D. and D.K. Strung. 1967. *Scour in Stone Bends*. Twelfth Congress of the International

Association for Hydraulic Research, CSU, Fort Collins, Colorado.

Smith, C.D. and D.G. Murray. 1965. "Cobble Lined Drop Structures." *Canadian Journal of Civil Engineering* 2(4).

Stevens, M.A. 1976. *Hydraulic Design Criteria for Riprapped Chutes and Vertical Drop Structures*. Denver, CO: Urban Drainage and Flood Control District, Denver, Colorado.

Stevens, M.A. 1981. *Hydraulic Design Criteria for Riprapped Chutes and Vertical Drop Structures*. Denver, CO: Urban Drainage and Flood Control District.

Stevens, M.A. 1983. *Monitor Report Bear Canyon Creek*. Denver, CO: Urban Drainage and Flood Control District.

Stevens, M.A. 1989. *Anderson's Method of Design Notes, August 1982*. Denver, CO: Urban Drainage and Flood Control District.

Stevens, M.A., D.B. Simons, and G.L. Lewis. 1976. "Safety Factors for Riprap Protection." *Journal of Hydraulics Division* 102(HY5)637-655.

Stevens, M.A., D.B. Simons, J.F. Watts. 1971. *Riprapped Basins for Culvert outfalls*. Highway Research Record No. 373, HRS, p.24-38.

Stevens, M.A. and B.R. Urbonas. 1996. *Design of Low Tailwater Riprap Basins for Storm Sewer Pipe Outlets*. Flood Hazard News 26(1)11-14. Denver, CO: Urban Drainage and Flood Control District.

Taggart, W.C. 1984. *Modifications of Dams for Recreational Boating*. Water for Resource Development, 781-785. New York: American Society of Civil Engineers.

Taggart, W.C., C.A. Yermoli, S. Montes, and A.T. Ippen. 1972. *Effects of Sediment Size and Gradation on Concentration Profiles for Turbulent Flow*. Cambridge, MA: Department of Civil Engineering, Massachusetts Institute of Technology.

Taylor, D.W. 1967. *Fundamentals of Soil Mechanics*. New York: John Wiley and Sons.

Taylor, E.H. 1944. "Flow Characteristics at Rectangular Open Channel Junctions." *American Society of Civil Engineers Transactions*, 109, Paper No. 2223.

Terzaghi, K. and R.B. Peck. 1948. *Soil Mechanics in Engineering Practice*. New York: John Wiley and Sons, Inc.

Toso, J.W. 1986. *The Magnitude and Extent of Extreme Pressure Fluctuations in the Hydraulic Jump*. Ph.D. Thesis, University of Minnesota.

Toso, J.W. and C.E. Bowers. 1988. "Extreme Pressures in Hydraulic-Jump Stilling Basins." *Journal of Hydraulic Engineering* 114(HY8).

U.S. Army Corp of Engineers (USACE). 1952. *Hydrologic and Hydraulic Analysis, Computation of Backwater Curves in River Channels*. Engineering Manual. Washington, DC: Department of the Army.

U.S. Army Corp of Engineers (USACE). 1947. *Hydraulic Model Study—Los Angeles River Channel Improvements*. Washington, DC: Department of the Army.

- U.S. Army Corp of Engineers (USACE). 1964. *Stability of Riprap and Discharge Characteristics, Overflow Embankments, Arkansas River, Arkansas*. Technical Report No. 2-650. Vicksburg, MS: U.S. Army Engineer Waterways Experiment Station.
- U.S. Army Corp of Engineers (USACE). 1980. *Hydraulic Design of Reservoir Outlet Works*. EM 1110-2-1602. Washington, DC: Department of the Army.
- U.S. Army Corp of Engineers (USACE). 1982. *HEC-2 Water Surface Profile Users Manual*. Davis, CA: Hydrologic Engineering Center.
- U.S. Army Corp of Engineers (USACE). 1984. *Drainage and Erosion Control Mobilization Construction*. EM 1110-3-136. Washington, DC: Department of the Army.
- U.S. Army Corp of Engineers (USACE). 1985. *Summary Report Model tests of Little Falls Dam Potomac River, Maryland*. Washington, DC: Army Corps of Engineers.
- U.S. Army Corp of Engineers (USACE). 1994. *Hydraulic Design of Flood Control Channels*. EM 1110-2-1601. Washington, DC: Department of the Army.
- U.S. Bureau of Public Roads. 1967. *Use of Riprap for Bank Protection*. Hydraulic Engineering Circular, No. 11. Washington, DC: Department of Commerce.
- U.S. Bureau of Reclamation (USBR). 1958. *Guide for Computing Water Surface Profiles*. Washington, DC: U.S. Department of the Interior, Bureau of Reclamation.
- U.S. Bureau of Reclamation (USBR). June 1, 1955. Research Studies on stilling basins, energy dissipators, and associated appurtenances, *Hydraulic Laboratory Report No. Hyd-399*.
- U.S. Bureau of Reclamation (USBR). 1987. *Design of Small Dams*. Denver, CO: Bureau of Reclamation.
- U.S. Federal Highway Administration (FHWA). 1960. *Hydraulics of Bridge Waterways*. Hydraulic Design Series No. 1. Washington, DC: FHWA.
- U.S. Federal Highway Administration (FHWA). 1978. *Hydraulics of Bridge Waterways*. Hydraulic Design Series No. 1. Washington, DC: Department of Transportation.
- U.S. Federal Highway Administration (FHWA). 1988. *Design of Roadside Channels with Flexible Linings*. Hydraulic Engineering Circular No. 15. Washington, DC: Department of Transportation.
- U.S. Federal Highway Administration (FHWA). 2000. *Hydraulic Design of Energy Dissipators for Culverts and Channels*. Hydraulic Engineering Circular 14. Washington, DC: U.S. Department of Transportation, FHWA.
- U.S. Soil Conservation Service (SCS). 1952. *Drop Spillways*. SCS Engineering Handbook, Section 11. Washington, DC: U.S. Department of Agriculture.
- U.S. Soil Conservation Service (SCS). 1976. *Chute Spillways*. SCS Engineering Handbook, Section 14. Washington, DC: U.S. Department of Agriculture.
- U.S. Soil Conservation Service (SCS). 1976. *Hydraulic Design of Riprap Gradient Control Structures*. Technical Release No. 59. Washington, DC: U.S. Department of Agriculture.

- U.S. Soil Conservation Service (SCS). 1977. *Design of Open Channels*. Technical Release No. 25. Washington, DC: U.S. Department of Agriculture.
- Urbonas, B.R. 1968. Forces on a Bed Particle in a Dumped Rock Stilling Basin. M.S.C.E. Thesis.
- Urbonas, B.R. 1986. Design of Channels with Wetland Bottoms. Supplement to *Flood Hazard News*.
- Walbridge, C. and J. Tinsley. 1996. *The American Canoe Association's River Safety Anthology*. Birmingham, AL: Menasha Ridge Press.
- Wang, S. and H.W. Shen. 1985. Incipient Sediment Motion and Riprap Design. *Journal of Hydraulic Engineering* 111(HY3)520-538.
- Webber, N.B. and C.A. Greated. 1966. An Investigation of Flow Behaviors at the Junction of Rectangular Channels. *Proceedings of the Institution of Civil Engineers* 34, Paper No. 6901
- Wheat, D. 1989. *Floater's Guide to Colorado*. Helena, MT: Falcon Press Publishing.
- Wittler, R.J. and S.R. Abt. 1988. Riprap Design by Modified Safety Factor Method. In *ASCE National Conference on Hydraulic Engineering*. New York: ASCE.
- Wright, K.R. 1967. Harvard Gulch Flood Control Project. *Journal of the Irrigation and Drainage Division* 93(1)15-32.
- Wright, K.R., J.M. Kelly, R. J. Houghtalen, and M.R. Bonner. 1995. Emergency Rescues at Low-Head Dams. Presented at the Association of State Dam Safety Officials Annual Conference in Atlanta.
- Wright, K. R. J.M. Kelly and W.S. Allender. 1995. Low-Head Dams Hydraulic Turbulence Hazards. Presented at the American Society of Civil Engineers Conference on Hydraulic Engineering and the Symposium on Fundamental and Advancement in Hydraulic Measurements.
- Yarnell, D.L. 1934. Bridge Piers as Channel Obstruction. Technical Bulletin No. 442. Washington, DC: U.S. Soil Conservation Service

## Appendix A. Force Analysis for Grade Control Structures

Each component of a drop structure has forces acting upon it that require evaluation. This section describes the general forces, with the exception of forces on riprap for which the reader is referred to Isbash 1936; Oliver 1967; Smith 1975; Smith and Strung 1967; Stevens 1976; Taggart 1984; Abt 1986 and 1987; Wittler and Abt 1988; Maynard and Ruff 1987; Richardson 1988; and LSA 1986 and 1989. It is worth noting that the boulders are subject to all of the usual forces plus the hydrodynamic forces of interflow through voids and related pressure fluctuations. A complete presentation of forces acting on riprap and boulders is not presented herein. Forces are described here, as they would apply to sloping grouted boulder and reinforced concrete drop structures.

The various criteria for structural slab thicknesses given for each type of drop structure have generally taken these forces into consideration. It is the user's responsibility to determine the forces involved.

Five location points are of concern. Point 1 is downstream of the toe, at a location far enough downstream to be beyond the point where the deflection (turning) force of the surface flow occurs. Point 2 is at the toe where the turning force is encountered. Point 3 is variable in location to reflect alternative drain locations. When a horizontal drain is used, Point 3 is at a location where the drain intercepts the subgrade of the structure. Point 4 is approximately 50% of the distance along the drop face. Point 5 is at a point underneath the grout layer at the crest and downstream of the cutoff wall.

Point 3 is usually the critical pressure location, regardless of the drain orientation. In some cases, Point 1 may also experience a low safety factor when shallow supercritical flow occurs, such as when the jump washes downstream.

Seepage uplift is often an important force controlling structure stability. Weep drains, the weight of the structure, and the water on top of the structure counteract uplift. The weight of water is a function of the depth of flow. Thus, greater roughness will produce deeper flow resulting in greater weight.

### Shear Stress

The normal shear stress equation is transformed for unit width and the actual water surface profile by substituting  $S_e$ , the energy grade line slope for  $S_o$ , the slope of the drop face.

$$\tau = \gamma y S_e \quad \text{Equation A-1}$$

Where:

$\tau$  = shear stress (lbs/ft<sup>2</sup>)

$\gamma$  = specific weight of water (lbs/ft<sup>3</sup>)

$y$  = depth of water at analysis point (ft)

### Buoyant Weight of Structure

Each design should take into consideration the volume of grout and rock or reinforced concrete and the density of each. In the case of reinforced concrete, 150 pounds per cubic foot can be used as the specific weight (or 88 pounds per cubic foot net buoyant weight). Specific weight of rock is variable depending on the nature of the material.

### Impact, Drag and Hydrodynamic Lift Forces

Water flowing over the drop will directly impact any abrupt rock faces or concrete structure projections into the flow. Technically, this is considered as a type of drag force, which can be estimated by equations found in various references. Impact force caused by debris or rock is more difficult to estimate because of the unknown size, mass, and time elapsed while contact is made. Therefore, it is recommended that a conservative approach be taken with regard to calculating water impact (drag force), which generally will cover other types of impact force. Specialty situations, where impact force may be significant, must be considered on an individual basis. In addition, boulders and riprap are subject to hydrodynamic lift forces (Urbonas 1968) that are caused by high velocities over the top of the stones and the zones of separation they create, resulting in significant reduction in pressure on the top while hydrostatic pressure remains unchanged at the stone's bottom.

### Turning Force

A turning force impacts the basin as a function of slope change. Essentially, this is a positive force countering uplift and causes no great stress in the grouted rock or reinforced concrete. This force can be estimated as the momentum force of the projected jet area of water flowing down the slope onto the horizontal base and calculating the force required to turn the jet.

### Friction

With net vertical weight, it follows that there would be a horizontal force resisting motion. If a friction coefficient of 0.5 is used and multiplied by the net weight, the friction force to resist sliding can be estimated.

### Frost Heave

This value is not typically computed for the smaller drop structures anticipated herein. However, the designer should not allow frost heave to damage the structure and, therefore, frost heave should be avoided and/or mitigated. In reinforced concrete, frost blankets, structural reinforcing, and anchors are sometimes utilized for cases where frost heave is a problem. If gravel blankets are used, then the seepage and transmission of pressure fluctuations from the hydraulic jump are critical.

### Seepage Uplift Pressure

As explained previously, uplift pressure and seepage relief considerations are critical to structural stability and usually of greater concern than the forces described above. There can be troublesome pressure differentials from either the upstream or downstream direction when there is shallow supercritical flow on the drop face or in the basin. One may consider an upstream cutoff to mitigate this problem. Weep locations with proper seepage control may be provided. For high drop structures (i.e., > 6 feet), more than one row of weep holes may be necessary.

A prudent approach is to use a flow net or other type of computerized seepage analysis to estimate seepage pressures and flows under a structure.

### Dynamic Pressure Fluctuations

Laboratory testing (Toso 1986; Bowers and Toso 1988) has documented that the severe turbulence in a hydraulic jump can pose special problems often ignored in hydraulic structures. This turbulence can cause significant positive and negative pressure fluctuations along a structure. The key parameter is the coefficient of maximum pressure fluctuation,  $C_{p-max}$ , which is in terms of the velocity head of the supercritical flow just upstream of the jump:

$$C_{p-max} = \frac{\Delta P}{\left(\frac{V_u^2}{2g}\right)} \quad \text{Equation A-2}$$

Where:

$\Delta P$  = pressure deviation (fluctuation) from mean (ft)

$V_u$  = incident velocity (just upstream of jump) (ft/sec)

$g$  = acceleration of gravity (ft/sec<sup>2</sup>)

Effectively,  $C_p$  is a function of the Froude number of the supercritical flow. The parameter varies as a function of  $X$ , which is the downstream distance from the beginning of the jump to the point of interest.

Table 9-6 presents recommended  $C_{p-max}$  positive pressure values for various configurations. When the Froude number for the design case is lower than those indicated, the lowest value indicated should be used (do not reduce on a linear relationship) for any quick calculations. The values can be tempered by reviewing the  $C_p$  graphs, a few of which are given in Figures A-1 and A-2. Note that the graphs are not maximum values but are the mean fluctuation of pressure. The standard deviation of the fluctuations is also indicated, from which the recommended  $C_{p-max}$  values were derived.

#### Dynamic Pressure Fluctuation Example

A good example of this is when an entire sloping face of a drop is underlain by a gravel seepage blanket. The gravel could be drained to the bottom of the basin or other locations where the jump will occur. In such a case, the positive pressure fluctuations could be transmitted directly to the area under the sloping face, which then could destabilize the structure since there would not be sufficient weight of water over the structure in the area of shallow supercritical flow.

Figure A-1 illustrates positive and negative pressure fluctuations in the coefficient,  $C_p$ , with respect to the location where the jump begins at the toe. Figure A-2 presents the positive pressure fluctuation coefficient where the jump begins on the face.

For the typical basin layouts given and where the drains are at the toe and connect directly to the supercritical flow, these pressure fluctuations should not be of great concern. However, when drains discharge to the jump zone and could transfer pressure fluctuations to areas under supercritical flow, pressure fluctuations are of concern.

**Table 9-6. Nominal limit of maximum pressure fluctuations within the hydraulic jump (Toso 1986)**

Jump Condition	Froude Number	Suggested Maximum $C_p$
0° slope, developed inflow (boundary layer has reached surface)	3.0	1.0
30° slope, toe of jump at base of chute <sup>1</sup>	3.8	0.7
30° slope, toe of jump on chute <sup>1</sup>	3.3	0.8

<sup>1</sup> Velocity head increased by elevation difference between toe of jump and basin floor, namely, depth at the drop toe.

**Overall Analysis**

All of the above forces can be resolved into vertical and horizontal components. The horizontal components are generally small (generally less than 1 psi) and capable of being resisted by the weight of the grout, rock, and reinforced concrete. When problems occur, they are generally the result of a net vertical instability.

The overall (detailed) analysis should include reviews of the specific points along the drop structure and the overall drop structure geotechnical and structural stability. All steps of this detailed analysis are not necessary for design of drop structures along modest capacity grass-lined channels, provided that the design is developed using the guidelines and configurations presented in the following simplified analysis approach section and that other USDCM criteria are met. The critical design factors are seepage cutoff and relief and pressure fluctuations associated with the hydraulic jump that can create upward forces greater than the weight of water and structure over the point of interest. Underflow can easily lift a major slab of rock and grout and, depending upon the exposure, the surface flow could cause further weakening, undermining, or displacement. Generally, a 30-pound net downward safety allowance should be provided, and 60 pounds is preferred. An underdrain is generally needed to prevent hydrostatic uplift on the stones.

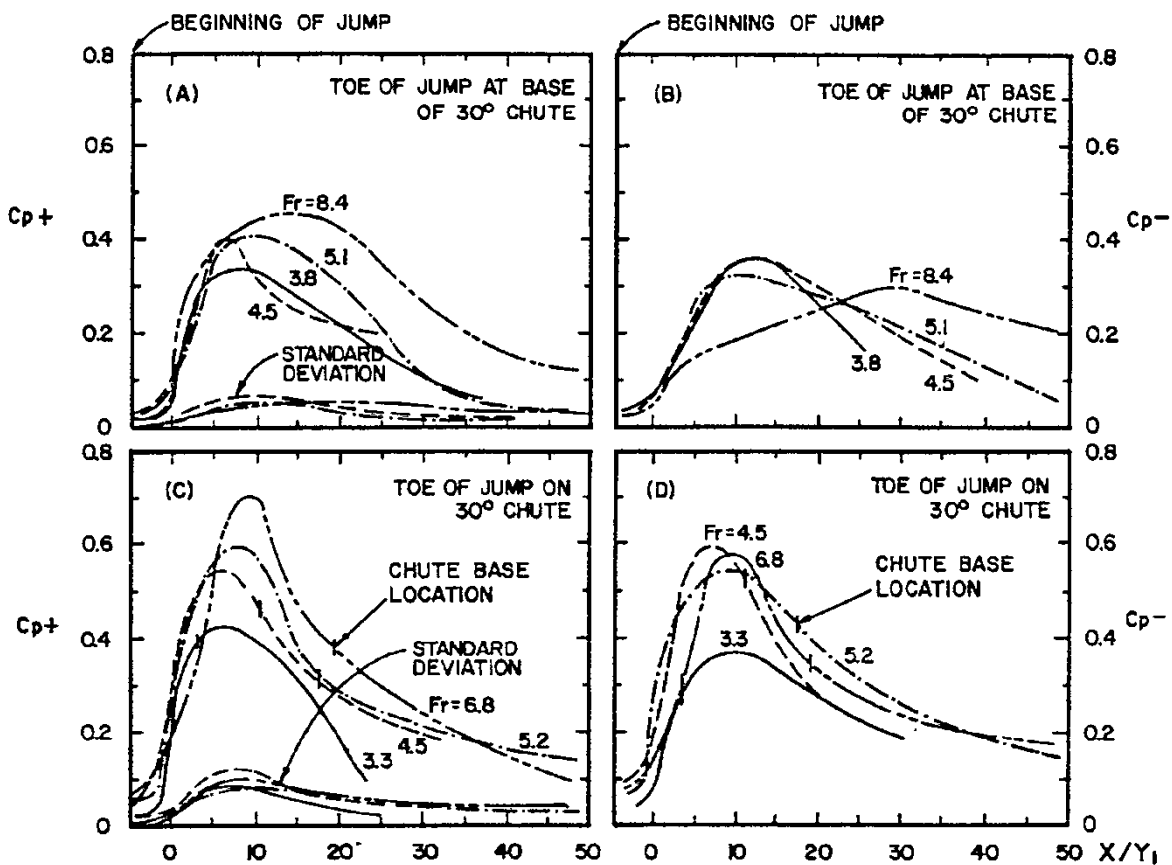


Figure A-1. Coefficient of pressure fluctuation,  $C_p$ , at hydraulic jump

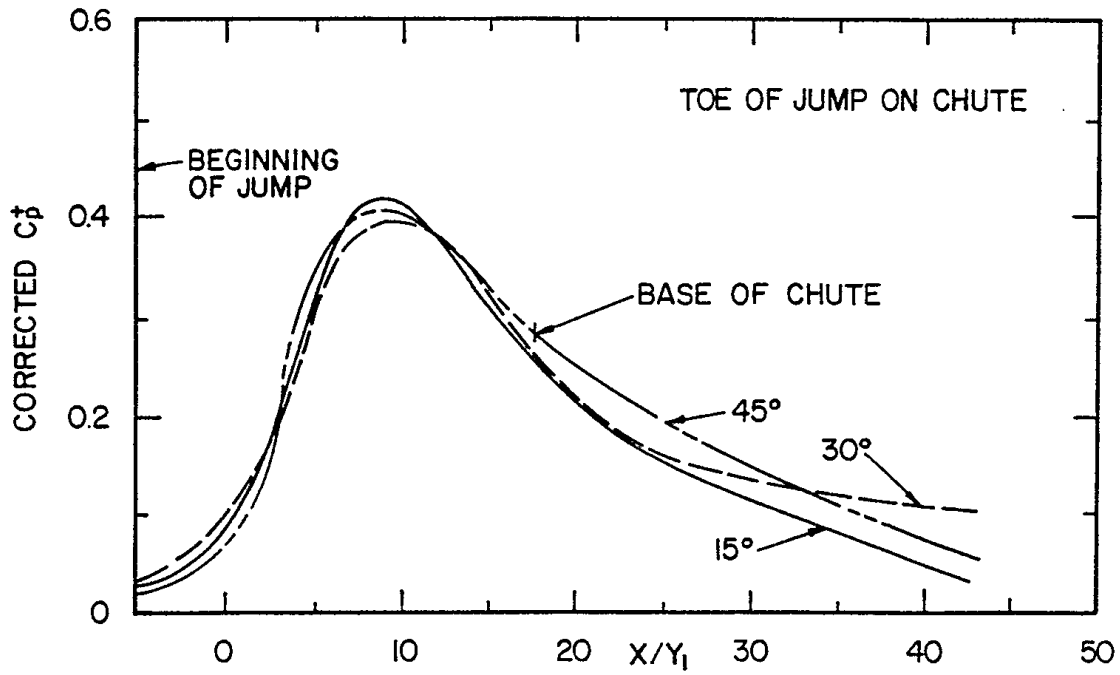


Figure A-2. Coefficient of pressure fluctuation,  $C_p$ , normalized for consideration of slope and jump beginning slope

# Chapter 10

## Stream Access and Recreational Channels

### Contents

- 1.0 Introduction and Overview ..... 1**
- 2.0 Public Safety Project Review ..... 2**
- 3.0 Shared-Use Paths Adjacent to Streams..... 4**
  - 3.1 Path Use ..... 4
  - 3.2 Frequency of Inundation ..... 5
  - 3.3 Path Geometry..... 7
    - 3.3.1 Typical Sections..... 7
    - 3.3.2 Use of Rails, Curb Rails, and Rumble Strips ..... 8
    - 3.3.3 Path Overtopping Protection ..... 12
    - 3.3.4 Vertical Clearance in an Underpass ..... 13
    - 3.3.5 Sight Distance ..... 14
  - 3.4 Path Drainage..... 19
    - 3.4.1 Cross Drainage..... 19
    - 3.4.2 Pumped Systems ..... 19
    - 3.4.3 Paths Adjacent to Walls ..... 19
  - 3.5 Path Underpasses ..... 19
    - 3.5.1 Path Underpass through a Bridge..... 20
    - 3.5.2 Path Underpass in a Culvert..... 20
    - 3.5.3 Floodwalls..... 20
    - 3.5.4 Culvert Geometry..... 21
    - 3.5.5 Lighting..... 21
    - 3.5.6 Underpass Drainage ..... 22
  - 3.6 Stream Crossings..... 23
    - 3.6.1 Crossing Type and Materials ..... 24
    - 3.6.2 Placement..... 24
    - 3.6.3 Equestrian Crossings..... 28
  - 3.7 Material Selection ..... 29
    - 3.7.1 Stabilized Rock and Reinforced Grass Paths ..... 29
    - 3.7.2 Crusher Fines ..... 30
    - 3.7.3 Asphalt ..... 30
    - 3.7.4 Concrete ..... 31
    - 3.7.5 Proprietary Surfaces..... 31
- 4.0 In-Channel Safety..... 32**
  - 4.1 Recreational and Boatable Channels ..... 33
    - 4.1.1 Recreational Channels..... 33
    - 4.1.2 Boatable Channels..... 34
  - 4.2 Glossary of Related Terms..... 36
  - 4.3 Minimum Criteria..... 39
  - 4.4 Design Considerations for Structures and Features..... 40
    - 4.4.1 Pinning and Overhead Obstructions..... 40
  - 4.5 Drop Structures ..... 41
    - 4.5.1 Overly-Retentive Hydraulic Jump ..... 42
    - 4.5.2 Design Approach ..... 47

4.5.3	Retrofitting Existing Structures .....	49
4.5.4	Integral Roughened Channel Fish Passage .....	49
4.5.5	Supplemental Guidance for Drop Structures .....	51
4.6	Bridge Piers or other Steep-Sided Structures .....	51
4.7	Access and Portages.....	52
4.8	Safety Signage .....	55
4.9	Maintenance Considerations .....	56
<b>5.0</b>	<b>References.....</b>	<b>57</b>

## Tables

Table 10-1.	Frequency of inundation criteria summary .....	6
Table 10-2.	Edge treatment criteria summary .....	9
Table 10-3.	Path geometry criteria summary .....	13

## Figures

Figure 10-1.	Thickened edge detail.....	12
Figure 10-2.	Rumble strip detail .....	15
Figure 10-3.	Typical path sections 1, 2, and 3. ....	16
Figure 10-4.	Path section with rumble strip .....	17
Figure 10-5.	Path section with rail .....	17
Figure 10-6.	Path section with vertical barriers on both sides .....	18
Figure 10-7.	Path underpass sections .....	22
Figure 10-8.	Typical low-flow crossing .....	25
Figure 10-9.	Crusher fines path section.....	30
Figure 10-10.	Concrete path section.....	31
Figure 10-11.	Zones of operation .....	32
Figure 10-12.	Overly-retentive currents at a hydraulic jump .....	44
Figure 10-13.	Forms of a hydraulic jump at an abrupt drop .....	45
Figure 10-13.	Forms of a hydraulic jump at an abrupt drop (continued) .....	46

## 1.0 Introduction and Overview

When channels are readily accessible to the public, public safety must be a primary design objective. The term “recreational channels” refers to all open channels that are readily accessible to the public. The planning, design, and construction of recreational channels should provide safe public access and use to all accessible areas. Unintended entry into the water by the public should also be considered during the planning and design phase. This chapter is relevant to virtually all open channels in urban areas and is largely focused on safety.

This chapter provides criteria and guidance for design of special structures, such as drop structures and pedestrian crossings, as well as larger scale considerations such as egress and signage for the length of a reach. It covers design of shared use paths, equestrian trails, low-flow crossings, underpasses, cross drainage and other considerations specific to paths adjacent to streams. This chapter also provides criteria for recreation channels that are also considered to be “boatable.”

Boatable channels represent a subset of recreational channels. Channels should be planned and designed to address public safety issues related to this use when they are considered to be boatable or this use is planned for the future or when the channel is classified by the Colorado Water Quality Control Commission as having existing or potential “primary contact use.”

Some boatable channel criteria may also be appropriate for recreational channels where boating does not typically occur. The degree of this consideration will depend on issues such as:

- Level of activity around the water’s edge both for current conditions and anticipated future uses,
- Frequency and range of flows within the recreational channel, and
- Potential consequences of accidentally falling into the water (low water and high water conditions).

## 2.0 Public Safety Project Review

As an increasing number of design professionals and developers promote the natural and beneficial functions of the floodplain, encouraging passive recreation in the floodplain and drawing people toward the water's edge, public safety becomes even more critical. This chapter focuses largely on to public safety issues, providing detailed criteria in Sections 3.0 and 4.0 for areas designed for some level of use by the public. This section, including the inset on the next page, is intended to identify when a comprehensive public safety review for a project is recommended and to guide the engineer and owner on key public safety issues. The safety criteria provided in the inset are additional to criteria provided in Sections 3.0 and 4.0 of this chapter. The *Public Safety Guidance for Urban Stormwater Facilities* (ASCE 2014) is also a good resource for public safety.

Although the engineer should consider public safety throughout the design process, the following siting and design components should trigger a comprehensive project review for public safety:

- Projects in densely populated areas and with populations that may require specific site requirements (e.g., high populations of children or elderly);
- Projects adjacent to schools, playgrounds, or within a public park;
- Projects designed with the intent to draw the public toward water,
- Drop structures taller than 3 feet from crest to stilling basin floor,
- Vertical drop structures of any height,
- Walls (including boulder walls and channel edging) exceeding 3 feet,
- Channel side slopes steeper than 4:1,
- Detention basins and outlet structures,
- Retention ponds and outlet structures,
- Inlets to storm drains and long culverts,
- Below grade paths, and
- Low-flow crossings.

The following considerations may be helpful when conducting this review:

- At what locations and with what frequency might a person become trapped by flood water?
- At what locations could signage be beneficial to public safety?
- What dry weather and wet weather risks exist in the project area?
- What locations present potential fall hazards during dry weather, wet weather, or when snow or ice is present?
- Do maintenance personnel have safe access to all required areas?
- How will channel degradation impact safety associated with various elements of the project?

**Public safety criteria found elsewhere in the Urban Storm Drainage Criteria Manual (USDCM):***From the Open Channels Chapter:*

Channel side slopes steeper than 2.5H:1V are considered unacceptable under any circumstances because of stability, safety, and maintenance considerations.

*From the Hydraulic Structures Chapter:*

Drop faces should have a longitudinal slope no steeper than 4(H):1(V). The formation of overly retentive hydraulics is a major drowning safety concern when constructing drop structures. Longitudinal slope, roughness and drop structure shape all impact the potential for dangerous conditions.

When designing [underground conveyance] systems with flared-end sections that are larger than 36 inches in diameter, pedestrian railing may be warranted if public access will occur. If this is the case, railing can be more easily mounted to a combination headwall/wingwall.

It is important to note that vertical [drop] structures can cause dangerous hydraulic conditions, including keeper waves, during wet weather and are generally discouraged. In addition, vertical drop structures are to be avoided due to impingement energy, related maintenance and turbulent hydraulic potential (ASCE and WEF 1992).

Vertical drops are not appropriate where fish passage is needed, design flow (over the length of the drop) exceeds 500 cfs or a unit discharge of 35 cfs/ft, net drop height is greater than 2 feet, or the stream is used for boating or there are other concerns related to in-channel safety.

*From the Culverts and Bridges Chapter:*

Based on UDFCD investigations of culvert and storm drain deaths, safety grating should be required when any of the following conditions are or will be true:

- It is not possible to “see daylight” from one end of the culvert to the other,
- The culvert is less than 42 inches, or
- Conditions within the culvert (bends, obstructions, vertical drops) or at the outlet are likely to trap or injure a person.

*From the Storage Chapter:*

The use of retaining walls within detention basins is generally discouraged due to the potential increase in long-term maintenance access and costs as well as concerns regarding the safety of the general public and maintenance personnel. Where walls are used, limit the length of the retaining walls to no more than 50 percent of the basin perimeter. Also, consider potential fall hazards associated with pedestrians, cyclists, and vehicles in determining the appropriate treatment between a sidewalk, path, or roadway and the top of the wall. Considerations include distance from the public to the wall, curvature of the path or roadway, single or terraced walls, and volume of traffic.

Potential solutions include dense vegetation, seat walls, perimeter fencing, safety railing and guardrail. In some cases walls less than 2 feet will warrant a hard vertical barrier; in other cases a 3 foot wall may be the point at which this barrier is appropriate. Check requirements of the local jurisdiction. UDFCD recommends providing a hard vertical barrier in any location where walls exceed 3 feet.

It should also be noted that retention ponds pose a greater risk to the public compared to detention basins and should be evaluated for unintentional entry by the public.

### 3.0 Shared-Use Paths Adjacent to Streams

This section provides guidance for shared use paths and equestrian trails, low-flow crossings, underpasses, cross drainage, and other considerations specific to paths adjacent to streams. Paths are an integral part of recreational channels, providing access for the public and channel maintenance. Paths are typically also part of the active conveyance area for the channel during a flood. When available, adhere to local jurisdiction shared-use path design criteria in addition to this section. The AASHTO Guide for Development of Bicycle Facilities is also an excellent reference and guidance and conformance to these criteria is frequently required for federally funded projects. Where criteria conflict, adhere first to local jurisdiction criteria, then this manual, followed by the AASHTO guide (when appropriate).

#### 3.1 Path Use

Paths are often constructed along streams to provide access for maintenance vehicles. However, if public access is provided to the path, it should be assumed that the path will be used by the public. For this reason, it is important to design paths with the health, safety, and welfare of the public as a primary design objective. It is also important to evaluate when it is appropriate for a path to conform to accessibility criteria. Accessibility is a requirement for all paths described in this section with few exceptions (e.g., a gated section of path not intended for any public use). Depending on the design, users may include bicyclists, pedestrians, runners, equestrians, dog walkers, people with baby carriages, people in wheelchairs, skate boarders, and others. Not all paths will be designed for all of these users, but the following can be considered when determining type of use of the path:

- Does this segment of path fit into an existing master plan where use has been determined?
- What connections are made with the path? Who are the likely users?
- How can the path best provide continuity between its connection points? Alternating segments (in regard to intended use, material, or geometry) should be minimized.

Determining the expected types of path users expected will help in establishing geometry, selecting construction materials and techniques, and understanding safety considerations.

#### Additional Resources for Path Design

- AASHTO Guide for the Development of Bicycle Facilities
- National Trails Training Partnership website
- NACTO Urban Bicycle Design Guide
- [www.bicyclinginfo.org](http://www.bicyclinginfo.org)
- Iowa Water Trails Toolkit, Iowa Department of Natural Resources FHWA Designing Sidewalks and Trails for Access
- FHWA Evaluation of Safety, Design, and Operation of Shared-Use Paths
- Architectural Barriers Act (ABA) Accessibility Standards
- Americans with Disability Act (ADA) Standards for Accessible Design

### 3.2 Frequency of Inundation

The frequency of inundation is one of the most important considerations for the design of a path adjacent to a stream. This criterion directly affects safety and maintenance and frequently impacts cost, conveyance capacity, and the users' path experience. Less frequent inundation is better from a safety and maintenance perspective. The public safety threat is especially high in channels susceptible to flash flooding and where egress from the channel section is limited (e.g., walled channels). Frequently inundated paths also require more frequent maintenance due to sediment deposit on the path surface and erosion at the path edges.

Removal of sediment after runoff events typically involves collection and disposal of sediments. Washing the sediment back into the channel would violate typical MS4 permit requirements. Additionally, sediment deposition between the channel and the path can impede drainage away from the path and result in water or ice on the path. Paths constructed with new channel or roadway improvements should be constructed above the 5-year water surface elevation or higher. For highly used paths an elevation above the 10-year water surface elevation is preferred.

For a retrofit project, the same standards should be met when practical; however, existing conditions may not allow this for the entire length of the path. In this case UDFCD strongly recommends that the design elevation remain above the 2-year water surface elevation at all locations. Changes in channel section can occur over time resulting in the increased frequency of overtopping in the future. For this reason, it is also good practice to set the surface of the path a minimum of two feet above the estimated base flow elevation. When existing conditions do not allow for a path elevation meeting either of these two criteria, consider alternative alignments.

Exceptions to the above criteria may be appropriate in the area of a low-flow stream crossing where the crossing could be designed to pass up to a 2-year event before overtopping. This should be evaluated on a case-by-case basis taking into consideration frequency of use and the importance of the crossing as a path connection component. Benefits of constructing a low-flow crossing include conserving flood capacity for higher flows, improving user experience by bringing the user in closer contact with the stream, and potentially eliminating railing that could otherwise catch debris, become a maintenance issue, and further impact the floodplain. However, low-flow crossings have attendant safety risks of their own. See Section 3.6 for additional guidance on stream crossings.



**Photograph 10-1.** Frequently inundated channels pose a high threat to public safety, especially in a walled channel where water can rise rapidly and egress is limited.



**Photograph 10-2.** Sediment frequently accumulates under crossings. Frequently inundated paths collect sediment and are maintenance-intensive.

Underpasses, where users frequently seek shelter in a storm event, present a more critical case for public safety as it relates to frequency of inundation. If the geometry of the surrounding area and configuration of the underpass combine to allow the user to see the water and seek higher ground, more frequent inundation may be acceptable. See Section 3.4 for additional guidance on underpasses.

Frequency of inundation criteria for paths is summarized in Table 10-1. Further discussion specific to path underpasses and stream crossings is provided in Sections 3.4 and 3.5.

**Table 10-1. Frequency of inundation criteria summary**

Path Type	Recommended Elevation (when practicable) (water surface elevation)	Minimum Elevation (water surface elevation)	Other Considerations
Stream Crossings	2 to 5-year	2-year	
Bridge Underpass	5-year	2-year	
Culvert Underpasses less than 100 feet in length	5-year	2-year	The user should be able to see when water is rising and climb to safety.
Culvert Underpasses greater than 100 feet in length	10-year	5-year	The culvert should be straight. The user should be able to see when water is rising and climb to safety.
All Other Locations (New)	10-year	5-year	Elevating the path to the 10-year WSE is preferred.
All Other Locations (Retrofit)	5-year	2-year	Where practicable also elevate the path two feet above the baseflow.

### 3.3 Path Geometry

#### 3.3.1 Typical Sections

The minimum recommended width for a path that facilitates light maintenance vehicles is ten feet. A reduced width typically results in edge damage from maintenance vehicles. This is also consistent with AASHTO's width recommendations for two-directional shared-use paths. In many cases it may be desirable to increase the width to 12 or even 14 feet to accommodate conflict points or when high volumes of users are anticipated. In very high-use areas multiple treads allow separation of uses that might conflict. An example of this is where the South Platte River path meets that of Cherry Creek. Within Confluence Park, users on foot and those on wheels are split on either side of the water. In the extremely high use area of Confluence Park where different users are not separated, the path is widened to 14 feet and all railing includes rub rails (see photo 10-22). Rub rails on bridges are horizontal members that help mitigate injury to cyclists crashing into them.

On each side of the path the adjacent grade (shoulder) should be no steeper than 6(H):1(V) for a minimum width of two feet. This is regardless of the edge treatment and provides a place for the user to safely move off the path and also protects the path from potential damage due to adjacent sloughing grade. Sloughing grade adjacent to the path can eventually undermine the path or cause a rumble strip to become separated from the path. It is best to provide a section in the construction drawings that shows the shoulder and specifically calls out for backfilling the sides of the path. When the site does not allow for a shoulder, a thickened edge (see Figure 10-1) can protect the path from being undermined and allow maintenance personnel time to identify and repair the problem.

In some cases (see Table 10-2), a safety rail parallel to the path is recommended. Rails are appropriate where a dangerous condition would otherwise exist. Common locations include steep side slopes, vertical walls, steep longitudinal slopes, bends, areas where cross drainages create isolated hazards, and where combinations of the above circumstances exist.

#### Trail Conflict Points

Trail conflict points include underpasses, trail intersections, blind corners, areas with steep grade and other locations where an accident between users is more likely to occur.

These areas require special consideration. Depending on the scenario, the following could be added to reduce the probability of or resulting damage from an incident:

- Railing
- Yellow Striping (indicating separation between two-directional users)
- Increased trail width
- Signage
- Wide-angle Mirrors
- Signals Lights



**Photograph 10-3.** Signage and striping help segregate bicyclists and pedestrians at Confluence Park where the two treads are separated by the creek.

### 3.3.2 Use of Rails, Curb Rails, and Rumble Strips

Rails, curb rails, rumble strips, increased path width, changes in texture and/or color, signage and striping are all tools that can be used to improve path safety and heighten user awareness of a new or changing condition. For the purpose of these criteria the term “edge treatment” refers to rails, curb rails, and rumble strips. All above-grade stream crossings should include an edge treatment. For all edge treatments, increase the width of the path (in addition to the width of the approaching path) to allow for placement of the treatment. See Figure 10-2 for rumble strip details. When using rails (curb rails or full rails), provide a minimum of one foot clear beyond the edge of the approaching path to the rail. See Table 10-2 for a summary of recommendations and Figures 10-2 through 10-8 for plan views and sections.

Use of full rails (typically 42 inches when bicyclists are anticipated and 54 inches when the path provides equestrian passage) can cause adverse flooding conditions and should only be used when a curb rail or rumble strip does not provide an acceptably safe condition for the user. When rails are used, the hydraulic model should consider the full area of the rail to be clogged with debris. Based on the experience of UDFCD, “break-away” rails which are designed to collapse during high flow, are often ineffective over time and should not be relied on for floodplain analysis (i.e., they too should be modeled as fully blocked).



**Photograph 10-4:** Rumble strips warn the user of the path edge without reducing capacity for flood flows. Photo Courtesy Architerra Group.



**Photograph 10-5.** Most of the “break-away” rails on this crossing failed to break despite the capacity lost to debris.



**Photograph 10-6.** Curb rails are typically no higher than 12 inches and can be constructed from a variety of materials.

**Table 10-2. Edge treatment criteria summary**

Path Type	Difference in elevation from path surface to adjacent grade (design <sup>1</sup> )	Edge Treatment
Paths perpendicular to the stream or in an underpass	Up to 36 inches	Rumble strip or curb rail
	up to 54 inches	Curb rail <sup>2</sup>
	Greater than 54 inches	Full rail <sup>3</sup> (typically 3'-6" inches for shared use and 4'-6" for equestrian)
Paths parallel to the stream and not in an underpass	Up to 36 inches	Rumble strip
	Greater than 36 inches or adjacent slope steeper than 3:1 <sup>3</sup>	Full rail <sup>3</sup> (typically 42 inches for shared use and 54 inches for equestrian)
<sup>1</sup> Values provided assume that differences in elevation following construction may potentially increase in some areas by up to 20% due to stream degradation. <sup>2</sup> Model flooding effects with rail fully clogged. <sup>3</sup> Span 100-year floodplain (preferred) or model flooding effects with rail fully clogged. <sup>4</sup> Adjacent slope refers to slope adjacent to the 2-foot shoulder.		



**Photograph 10-7.** Horizontal members are placed on the users' side of the posts. This is an important consideration for both shared-use paths and equestrian trails in that it reduces the chance of snagging clothing, a bike pedal or a stirrup.



**Photograph 10-8.** At Confluence Park a rub rail was included as part of the rail design. This, in addition to the 14-foot path width, improves safety in this high-use area.

### Considerations for Designing Safety Rails

- Minimize the likelihood of the rail catching debris. This is a maintenance issue and, if not maintained, can reduce capacity in the stream and cause flooding or damage to the safety rail
- Place horizontal members on the users' side of the posts. This provides a safer surface, less likely to catch clothing, a bike pedal, or a stirrup.
- Provide a rail height of at least 42 inches when cyclists are anticipated and 54 inches when the trail provides equestrian passage.
- Consider snow removal either by designing the rail to allow movement of snow through the bottom of the rail (without creating a safety hazard for small children) or by planning for snow storage in an alternate location.



**Photograph 10-9.** Striping used sparingly can be effective in alerting the user of a safety concern. In this photo, it is used where the path approaches a crossing.



**Photograph 10-10.** Along this section of the South Platte River, the combination of a steep longitudinal slope, a cross drainage structure, and a steep slope from the path to the water warranted both a safety rail and striping.

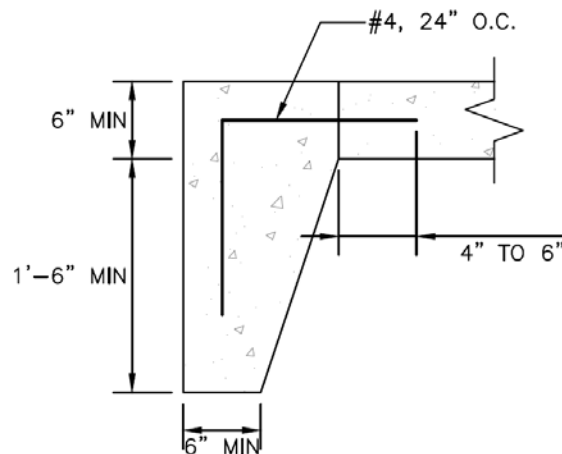
### 3.3.3 Path Overtopping Protection

Provide adequate protection to avoid damage caused when flows overtop the path. As a path turns perpendicular to the stream, or anywhere significant overland flows are likely to cross the path (e.g., downstream of side-channel spillways or at undersized culvert crossings), scour can occur along the downstream edge. This causes the path to act like a drop structure. Flows across the path accelerate, potentially damaging the upstream edge of the path, while scour downstream can eventually undermine the path (see Photo 10-11). For these reasons, a thickened edge on both the upstream and downstream sides of a path approaching a low crossing is recommended. The edge should extend a minimum of two feet below the surface of the path (see Figure 10-1). Soil riprap placed adjacent to the path can be used to provide additional protection.



**Photograph 10-11.** A soil cement path approaching a crossing on Sand Creek is undermined on the downstream side due to overtopping. Overtopping protection was not adequate to stop scour damage before losing a section of the path.

The length of the overtopping protection is site specific. If the bank of the channel is well defined, protection should extend from the crossing into the bank. If the bank is not well defined, extend the protection to a point where the path is more parallel with the stream than it is perpendicular. In either case, the length of overtopping protection typically does not need to extend higher than the 10-year surface elevation.



**Figure 10-1. Thickened edge detail**

### 3.3.4 Vertical Clearance in an Underpass

Maximizing vertical clearance improves the users’ experience on the path. It increases light in underpasses and helps open the area so users do not feel trapped by the walls of a structure. However, increasing vertical clearance can also increase frequency of inundation because often the top elevation of the structure is fixed by the profile of existing utilities or the roadway crossing the stream (i.e., the path must be lowered to increase vertical clearance). In cases where the desired vertical clearance cannot be met without lowering the path to an elevation below the 2-year water surface elevation (at a minimum), the vertical clearance must either be reduced to the minimum allowable clearance in Table 10-3 or an alternative crossing (e.g., at-grade) considered. Ramps up to an at-grade crossing provide a good alternative for the path user (where feasible) and also serve as an escape route during a flash flood.

Table 10-3 provides minimum values for vertical clearance for various types of paths. Minimum values may be lower than those published by local communities within the UDFCD boundary. They are based on the minimum reasonable value for the respective use listed. Always check local criteria and conform to their vertical clearance requirements.

**Table 10-3. Path geometry criteria summary**

Path Type	Minimum Width (feet)	Minimum Width for High Use or Conflict Areas <sup>3</sup> (feet)	Minimum Vertical Clearance for Consideration <sup>1</sup> (feet)	Typical Minimum Vertical Clearance <sup>2,4</sup> (feet)	Preferred Vertical Clearance <sup>4</sup> (feet)	Typical Materials <sup>5</sup>
Maintenance Only	10	12	8	8	10	Concrete, Reinforced Grass
Hiking trail Only	n/a	n/a	6.67	8	10	Compacted Soil, Crusher Fines <sup>3</sup> , Proprietary Materials
Shared-Use with Bicyclists	10	12 to 14	8	8 to 9	10	Concrete or Proprietary Material
Equestrian	1.5 to 2.5	8	10	10	12 to 14	Grass or Compacted Soil
<p>1 Represents the minimum clearance that should be considered.                  2 Represents typical minimum criteria common to reviewing agencies and owners.                  3 Also recommended where a rail or wall is placed on both sides of the path.                  4 Based on review of path criteria for several agencies nationwide. Values will vary based on community.                  5 Not intended to be limiting.</p>						

### 3.3.5 Sight Distance

In order to avoid a crash, a cyclist must have time to identify potential conflicts and react accordingly. For all hard paths, or where bicyclists are otherwise anticipated, refer to tables and charts provided in *AASHTO Guide for the Development of Bicycle Facilities* to calculate the appropriate sight distances.



**Photograph 10-12.** Despite striping and signage, bicyclists frequently speed through the University Boulevard underpass along the Cherry Creek path.



**Photograph 10-13.** Understanding the popularity of the Cherry Creek path, designers worked to make the underpass at University safe for bicyclists and pedestrians while working within the limitations of the existing site. Land was purchased to create a suitable turning radius at this 90 degree bend. This provides bicyclists with additional time to react to the unexpected.

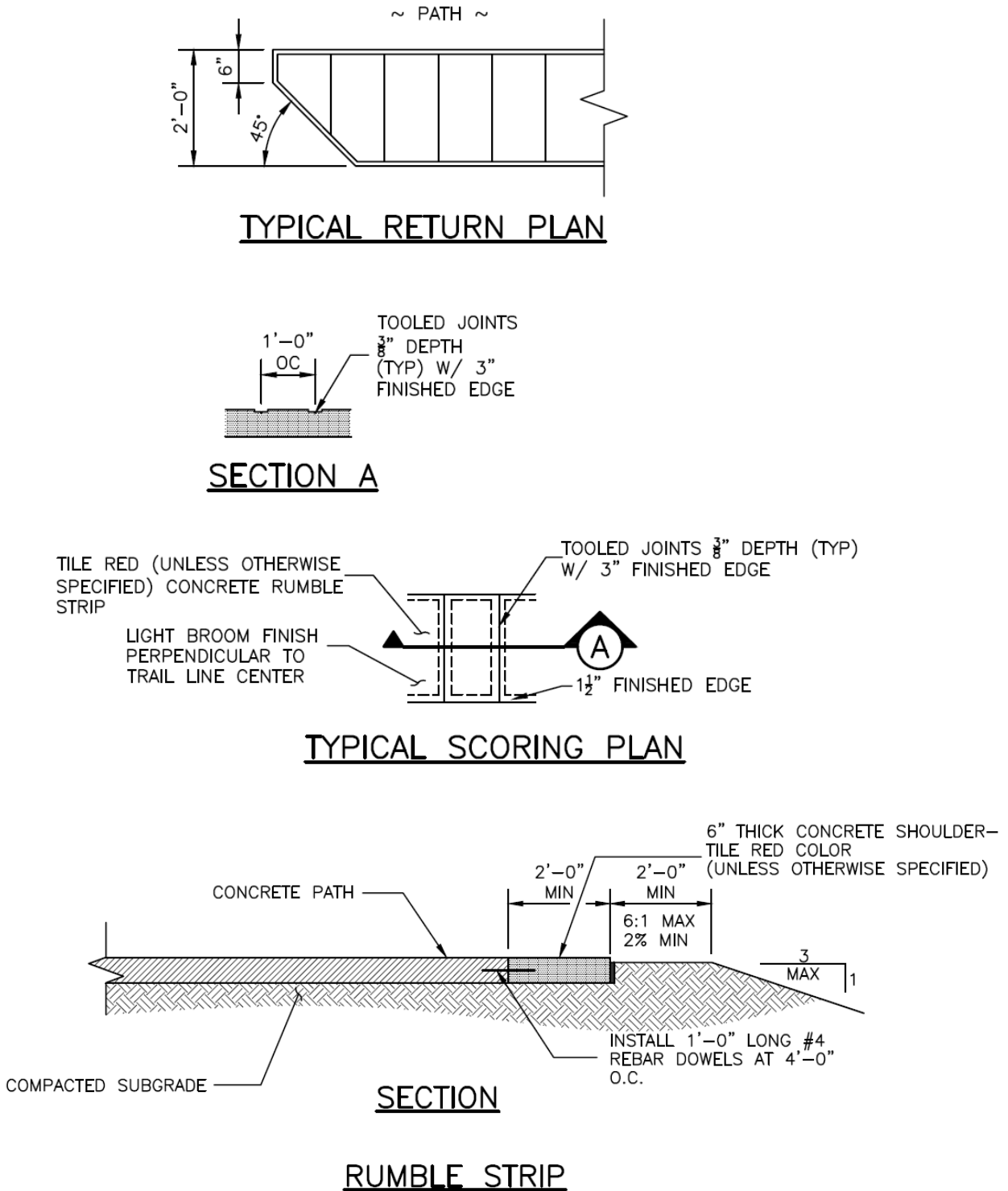


Figure 10-2. Rumble strip detail

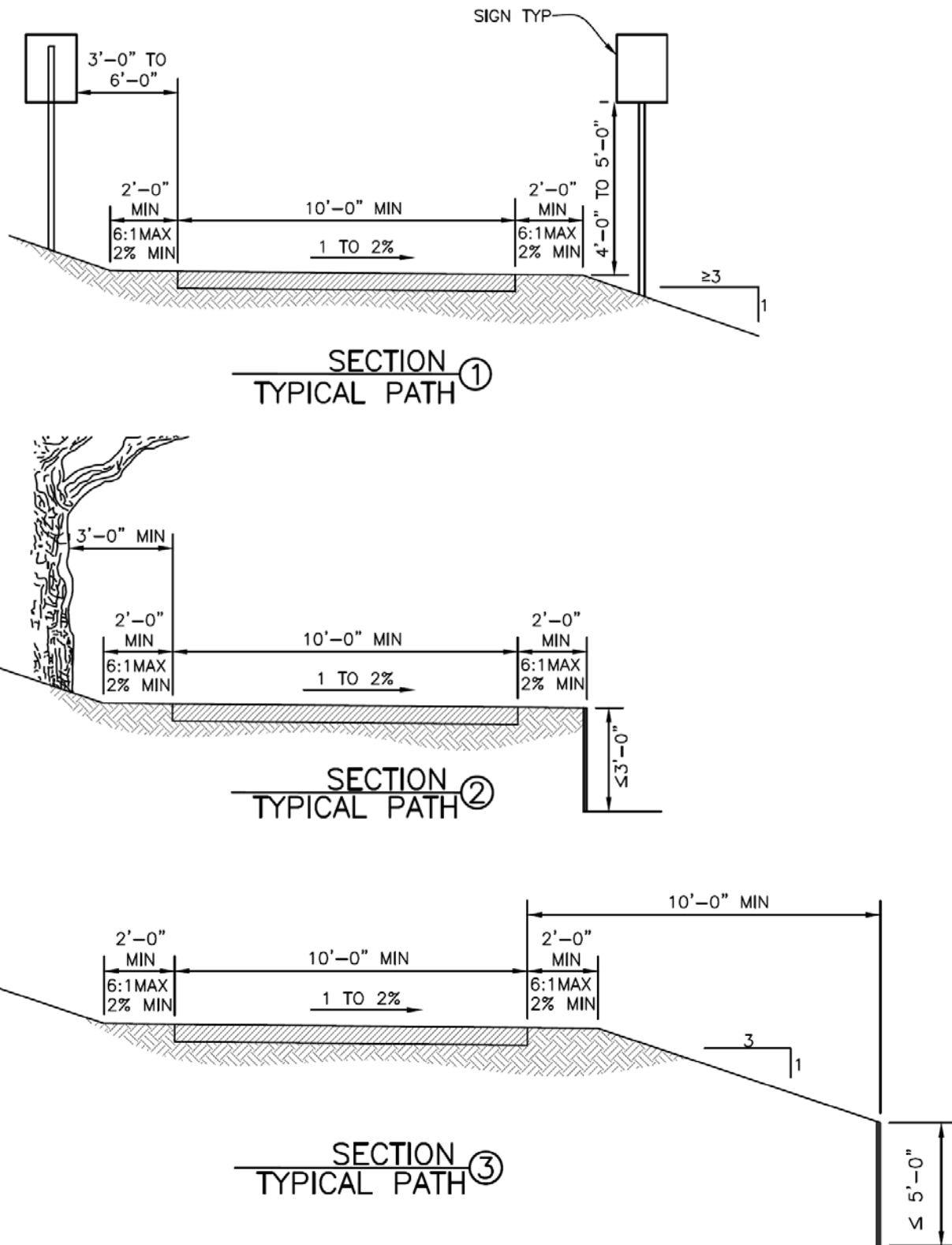


Figure 10-3. Typical path sections 1, 2, and 3.

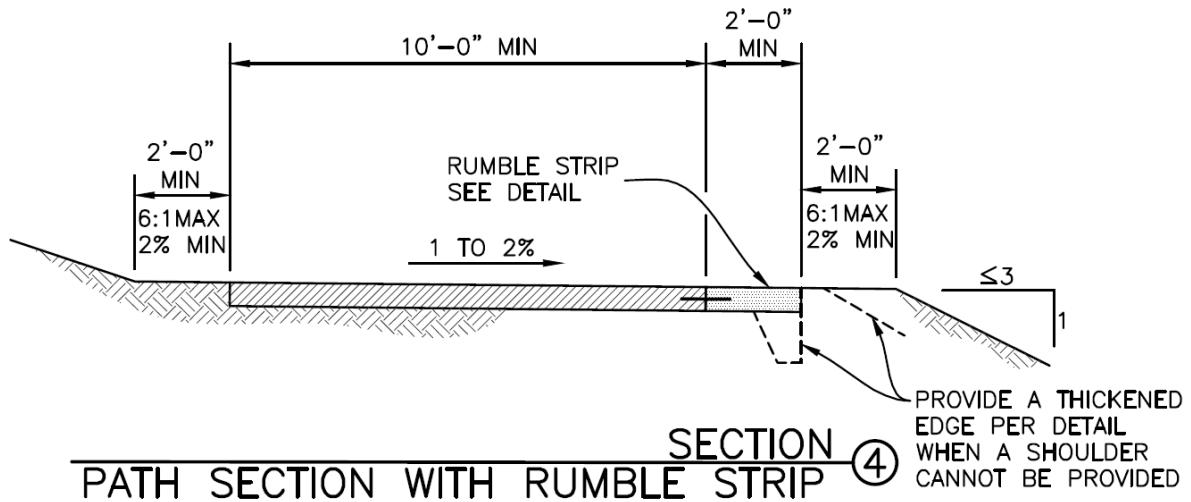


Figure 10-4. Path section with rumble strip

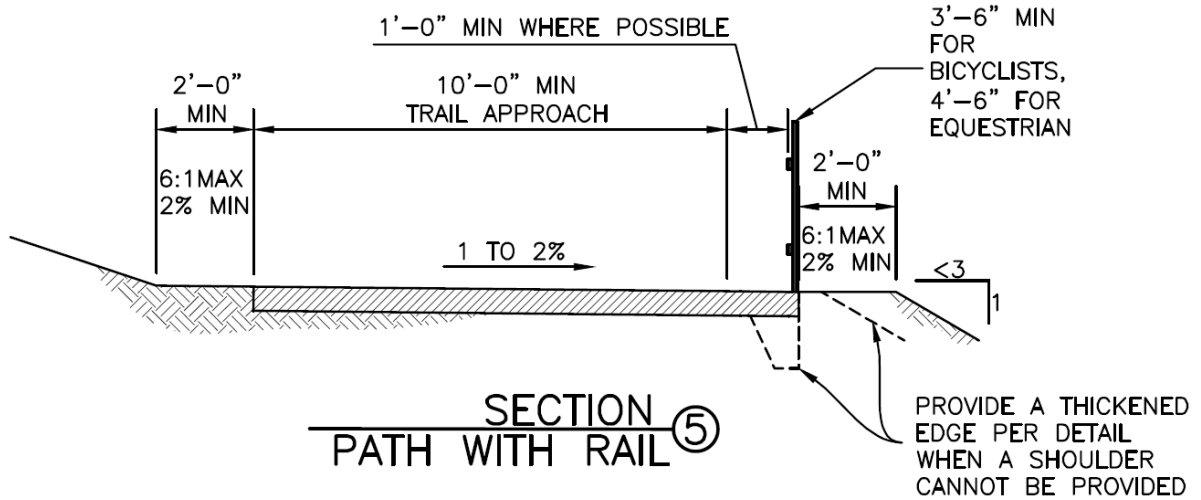
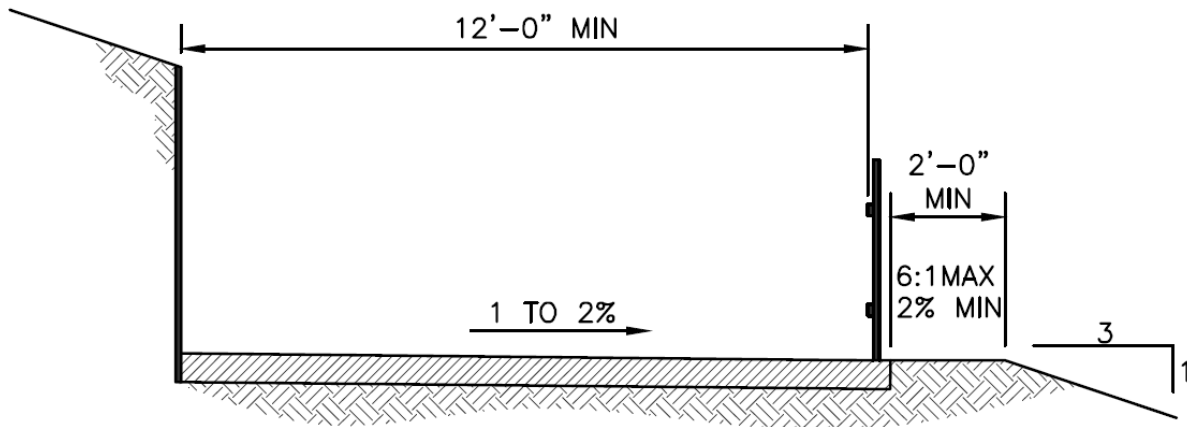


Figure 10-5. Path section with rail



SECTION ⑥  
PATH WITH VERTICAL BARRIERS

Figure 10-6. Path section with vertical barriers on both sides

### 3.4 Path Drainage

To avoid nuisance drainage problems, the path should have a cross slope toward the channel. The slope should not exceed two percent to meet accessibility requirements. Typically a cross slope of at least one percent coupled with a longitudinal slope provides adequate drainage. The bench on each side of the path should also be sloped a minimum of 2% to provide adequate drainage and should not exceed a slope of 6(H):1(V).

#### 3.4.1 Cross Drainage

Where outfalls intersect the path, provide culverts below the path to provide conveyance for frequent events. This will minimize disruption of path use and icing. For small outfalls located below the path, a level spreader, in combination with a riparian buffer may also be used to spread low-flows, improve water quality, and benefit vegetation. See the *Grass Swales* Fact Sheet in Chapter 4 of Volume 3 for more information on level spreaders. Similarly, other linear BMPs could also be used to reduce stormwater on the path. Where constraints exist, a chase may be used to keep frequent flows off the path. Be aware that chases tend to clog with leaves, trash, and other debris and require frequent maintenance to function properly. They can also become damaged during snow plow operations and can result in more frequent icing than piped conveyance. Additionally, metal chases should not be used on equestrian paths.

#### 3.4.2 Pumped Systems

In some locations, where an underpass is at a low point in the path, pump systems have been installed to drain the sump when water overtops the path. Electromechanical systems can be unreliable however, especially when needed most. Pumped systems can also require frequent and costly maintenance and may trigger requirements for water quality monitoring under an individual permit from the State. For all of these reasons UDFCD strongly discourages the use of pumped systems except as a last resort.

#### 3.4.3 Paths Adjacent to Walls

Consider discharge from weep holes. This can cause unexpected icing on the path after a warm day followed by a cold night. Where possible, it may be appropriate to collect this flow and convey it under the path.

### 3.5 Path Underpasses

At roadway crossings, there are generally three alternatives for path connections: path underpasses, at-grade crossings, and pedestrian bridges. The type of crossing selected effects user safety, user experience, animal passage, and cost. The scope of this manual focuses on underpasses. At-grade crossings and pedestrian bridges are not specific to streams and are covered in detail by other path design manuals.

Underpasses are the preferred alternative when the structure and roadway profile allow for the design to meet both vertical clearance and frequency of inundation criteria. Underpasses include (in order of preference) bridges, single span culverts,

#### Underpass Safety

Underpasses are often used for shelter during inclement weather. The following should be included where possible.

- Visibility of rising water from any location within the underpass
- Ability to climb to a higher elevation.
- Signage discouraging use of the underpass as a shelter and warning of potential flash flood. This signage should be placed inside the culvert or under the bridge. UDFCD encourages use of the sign shown in Photo 10-17 as a regional standard.

and multiple cell culverts. When both vertical clearance and frequency of inundation criteria cannot be met, other alternatives (i.e., at-grade crossings and pedestrian bridges) should be explored.

### 3.5.1 Path Underpass through a Bridge

Bridges with path crossings below are preferred over culverts because they provide the user with a wider field of vision and bring the user closer to the stream. This improves the experience for the path user, and from a safety perspective, is especially important along flashy streams, where being able to see water rising and climb to higher ground during a flash flood could save a life.

Bridges tend to be favored over culverts by the US Army Corps of Engineers (USACE) as they provide better wildlife passage and sometimes result in less impact to wetlands.

### 3.5.2 Path Underpass in a Culvert

Underpasses in a culvert are less desirable than bridges especially when the use of multi-cell culverts separates the user from the water. This creates a scenario where the user may not be aware that water is rising in other culverts and a potential flashflood threat exists. When a bridge cannot be provided, the design should include a connection to street level on both sides. This will ensure maintenance access and improve safety. A culvert underpass presents a location where users may seek shelter during rain or hail, placing them in danger from flooding. Provide signage inside each end of the culvert

to discourage users from seeking shelter within the structure. UDFCD recommends the sign provided in Photo 10-17 to promote consistency throughout the region.

The confined space within culvert underpasses can frighten horses, making them problematic for equestrian paths.

### 3.5.3 Floodwalls

A wall placed between the stream and the path to allow use of the path while flows exceed that of the path surface is a type of floodwall. The use of floodwalls to meet frequency of inundation criteria is discouraged. Floodwalls require a high level of maintenance with both sediment removal and nuisance drainage issues.



**Photograph 10-14.** This bridge offers safe passage, providing the user with a view of potentially rising water and the path beyond the structure. Additionally, the slope from the path to the roadway offers the user a passable route to higher ground in case of flash flooding.



**Photograph 10-15.** This single-cell three sided box culvert offers safe passage, providing the user with a view of potentially rising water and the path beyond the structure.



**Photograph 10-16.** Multi-cell culverts can be uninviting, especially if the user is not able to see the other end.

### 3.5.4 Culvert Geometry

Within any underpass, the path section should allow for pedestrians to safely move off the path if another user speeds by. For this reason, a shoulder is recommended on each side of the path (see Figure 10-3). This can be an extension of the path section or can be surfaced differently as long as it provides a stable surface (e.g., a rumble strip).

The length and geometry of the culvert also affect safety. The length should be minimized to enable the user to evacuate quickly. Long culverts (over 100 feet) should be elevated to the 5-year water surface elevation (at a minimum) and should be straight to increase visibility and natural light. Culverts in excess of 200 feet are strongly discouraged. Reducing the length may require increasing the size of the wing walls, raising the elevation of the path, and/or acquiring land and placing the culvert at an alternate location. When the culvert design length exceeds 200 feet consider an alternative crossing for the path, e.g. at-grade.

See the Path Geometry section and Table 10-3 for vertical clearance recommendations. Also consider the vertical alignment immediately upstream and downstream of the culvert as it relates to maintenance access and drainage. Ensure passage of maintenance vehicles through the culvert. This may require a vertical curve or shifting a grade break further away from the culvert. Where practical, drain water away from each end of the culvert in an effort to minimize flow on the path inside the culvert.

### 3.5.5 Lighting

The *AASHTO Guide for the Development of Bicycle Facilities* recommends average maintained horizontal illumination levels of 5 lux to 22 lux. Even relatively short culverts can require lights. Look for opportunities to increase natural lighting. This is especially important for long culverts (over 100 feet). Divided roadways sometimes allow for natural light to be brought in through a median. Bends reduce visibility and natural light in long culverts and should be avoided to the extent practicable.



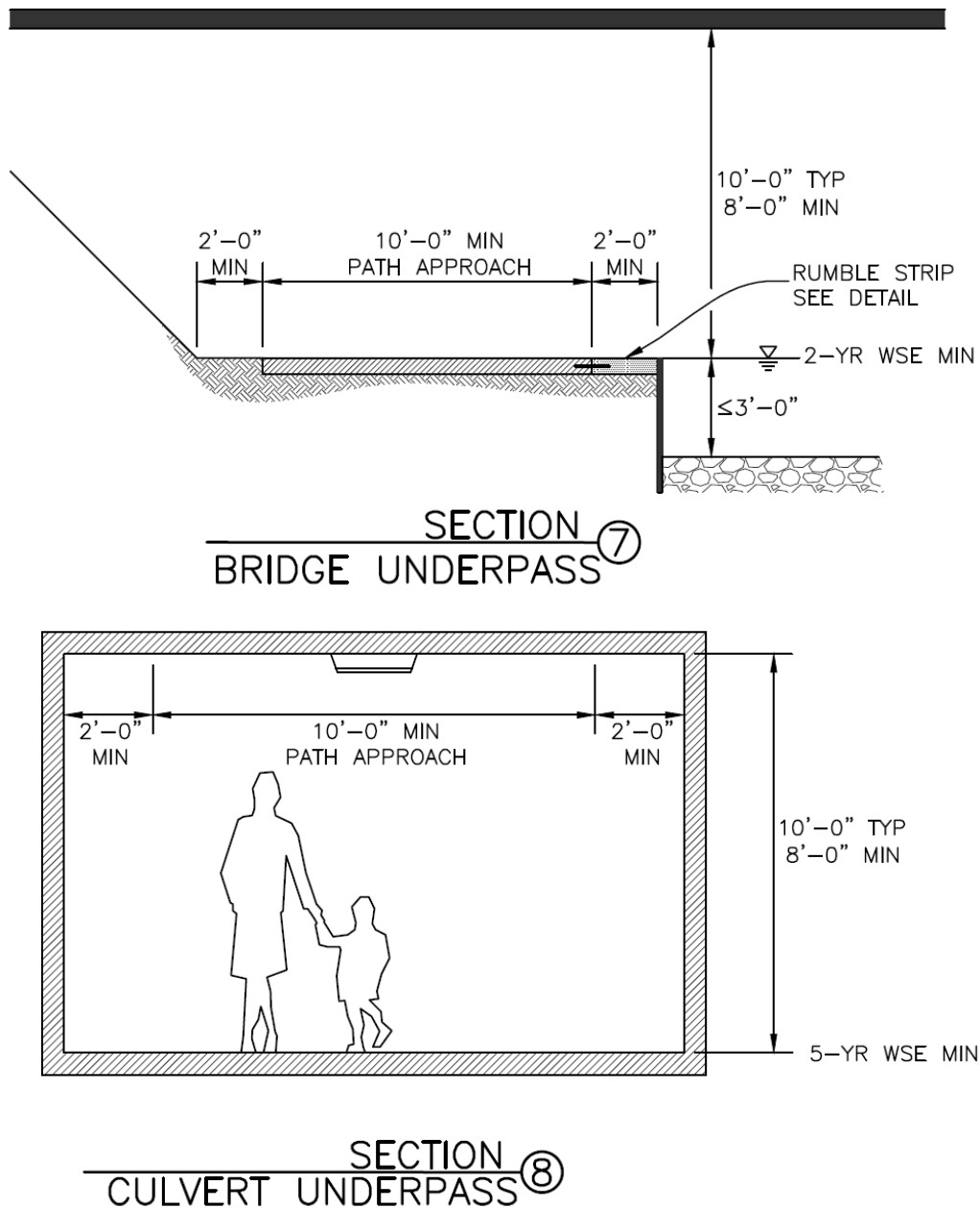
**Photograph 10-17.** Place cautionary signage inside the structure where it is most likely to be seen by someone using the culvert for shelter.



**Photograph 10-18.** A skylight between C-470 travel lanes brings natural light into the Willow Creek path underpass. Note also sediment deposition on path, typical of a long culvert with a mild slope. Photo courtesy City of Lone Tree.

### 3.5.6 Underpass Drainage

Drainage within the culvert is often problematic as well as maintenance-intensive. As shown in Photo 10-18, a long culvert constructed on a mild slope will deposit sediment on the path surface. The long flow path can exacerbate nuisance drainage issues and cause icing. When the design relies on inlets within the culvert, maintenance requirements should be specified to minimize problems due to clogging.



**Figure 10-7. Path underpass sections**

### 3.6 Stream Crossings

This section generally pertains to path crossings within the floodplain and includes structures that may be designed to overtop as frequently as during a 2-year event. These structures are sometimes referred to as low-flow crossings, low water crossings, or pedestrian crossings. These criteria are also intended for golf cart bridges, equestrian crossings, boardwalks, and any other similar structures with the exception of a temporary construction crossing. Discussion on larger crossings can be found in Chapter 8, *Hydraulic Structures*.

All stream path crossings need to be evaluated as part of the proposed hydraulic model and must be constructed to withstand forces associated with the 100-year flood event as well as wear and tear from frequent inundation without structural damage. Crossings should not include components that might break from the structure and cause debris blockage downstream. This can cause flooding and/or damage to downstream structures. All crossings should have a maintenance plan to address periodic and post-runoff debris and sediment removal. The designer should consider debris collection and blockage at the crossing and minimize potential for this while providing adequate safety components as described in this manual.



**Photograph 10-19.** A cast-in-place concrete culvert crossing with rumble strips. Photo Courtesy Architerra Group.



**Photograph 10-20.** This Cherry Creek crossing was split into three segments to accommodate the long span. Curb rails were used and the path was kept low to minimize impediment to flood flows. Photo Courtesy Muller Engineering.

### 3.6.1 Crossing Type and Materials

The two most common types of path crossings in the UDFCD region are bridges and cast-in-place concrete culverts. Bridges can be constructed in-place or prefabricated and can be concrete, wood, steel, or a combination of materials. Bridges, designed to span the main channel and sometimes other environmentally sensitive areas within the floodplain, can provide the benefit of reduced disruption when the project does not otherwise include disturbance of the channel. Concrete culverts can often be constructed without rails or with curb rails and provide a structure that has little impact to the water surface elevation of major events in the stream. Three-sided box culverts offer the added environmental benefit of a continuous streambed.



**Photograph 10-21.** A Bear Creek cast-in-place concrete culvert crossing with rumble strips and a crossing with rails in the distance.

### 3.6.2 Placement

When the placement of a crossing is flexible, (i.e., not dictated by existing constraints), the designer can add more thoughtfully considered user experience and potential future geomorphic changes to the requisite safety considerations. As discussed in Section 3.2, elevation of the path as it relates to frequency of inundation is an important consideration as the invert of the channel can change over time. Locating a crossing just upstream of a grade stabilization structure (check or drop structure) or incorporating a crossing into a grade stabilization structure, offers a stable channel invert at the crossing. This means the channel invert should not increase, causing more frequent inundation and related maintenance and loss of use issues, and that it also should not decrease, causing a potentially dangerous condition for the user. Depending on the design, locating a crossing downstream of a drop structure may offer the same benefit and also benefit user experience, bringing the user in contact with the sight and sound of the water flowing over the drop.



**Photograph 10-22.** A pedestrian bridge crossing with rails at Confluence Park.

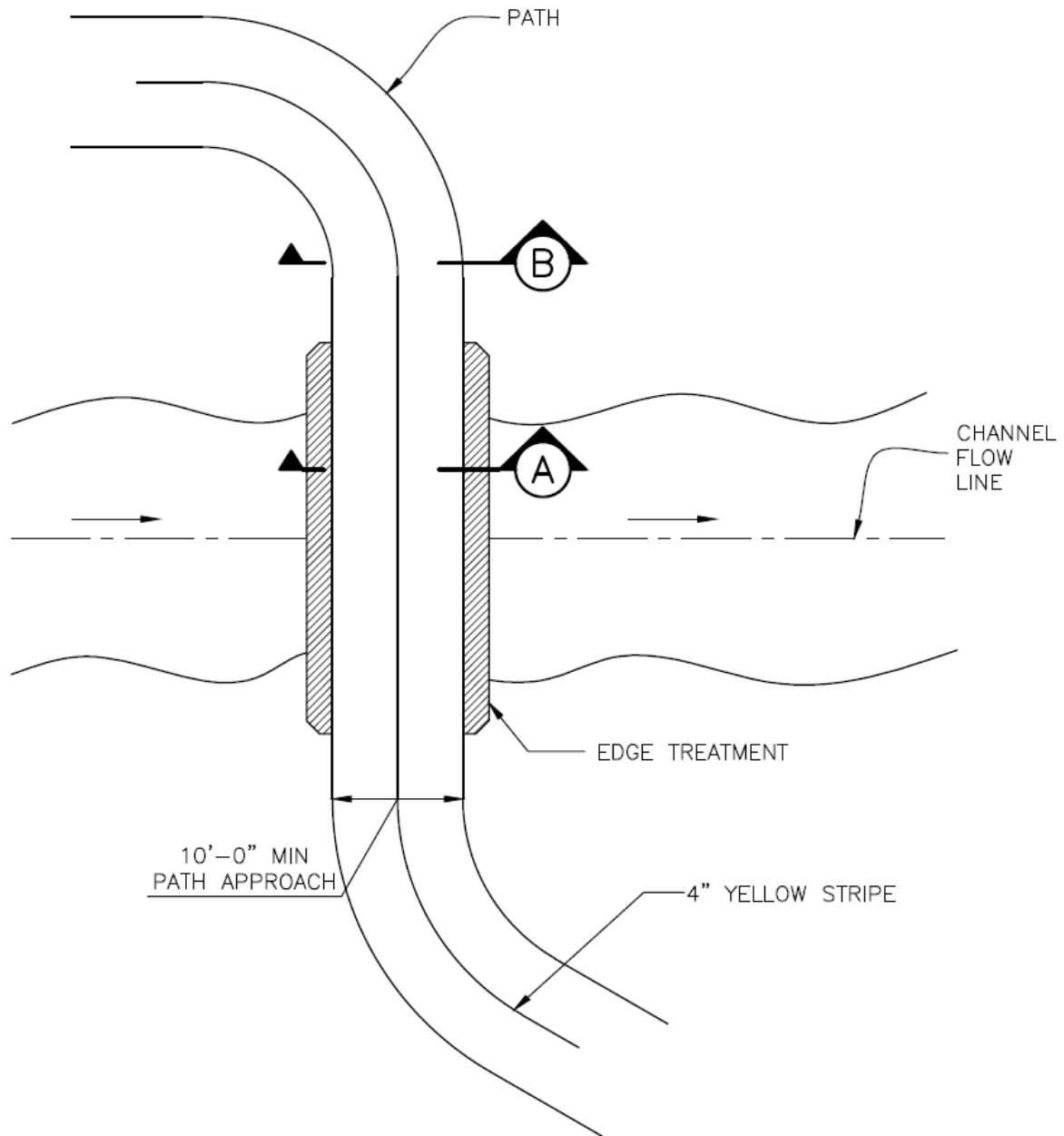
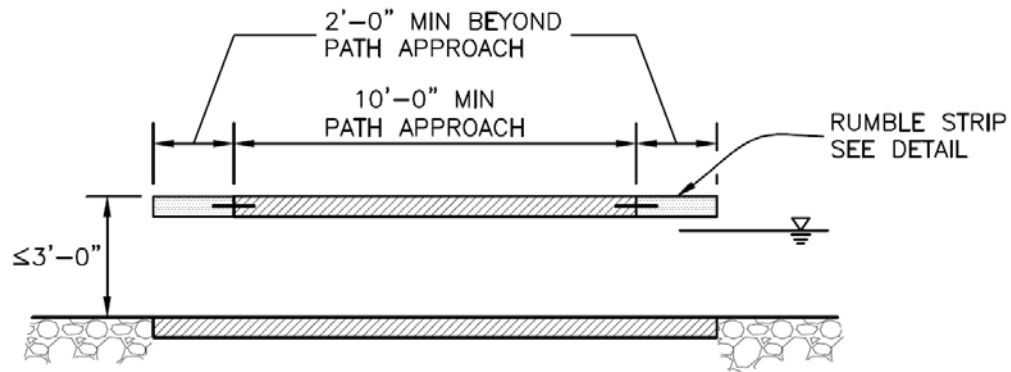
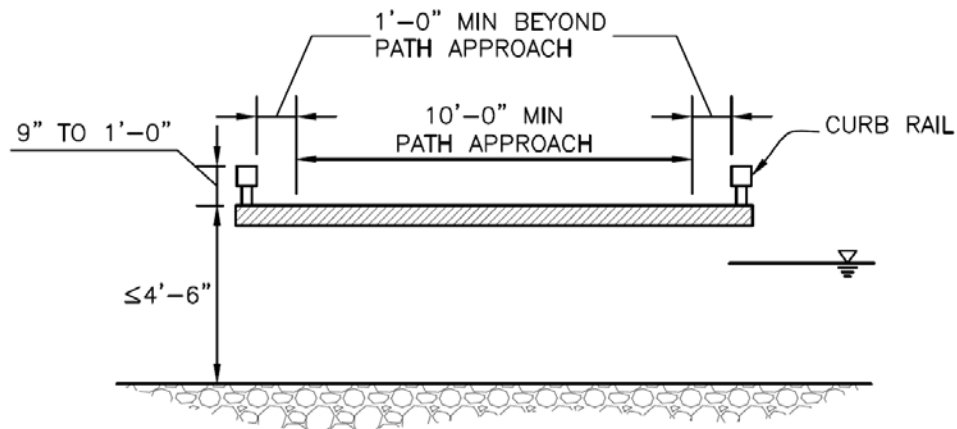


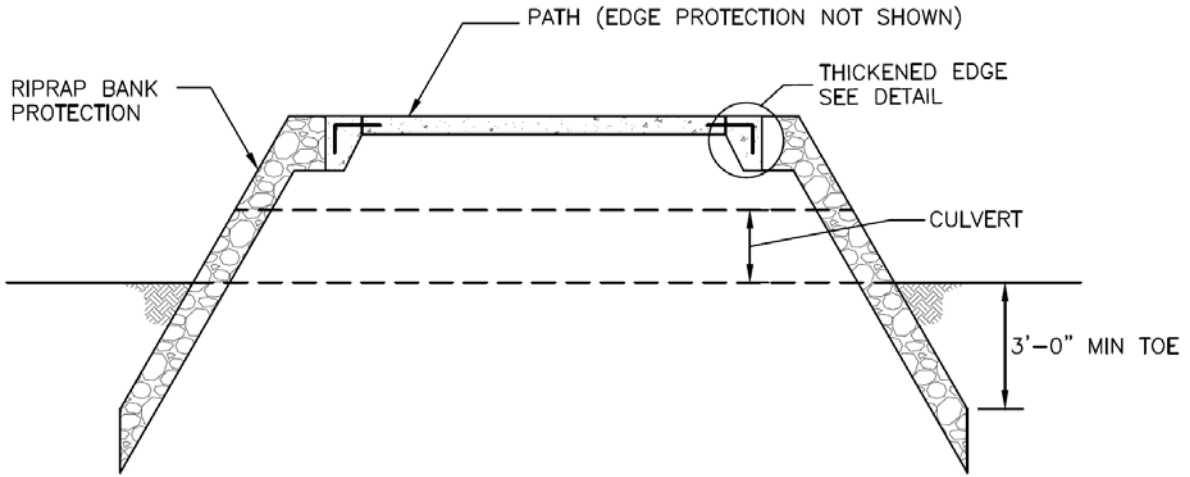
Figure 10-8. Typical low-flow crossing



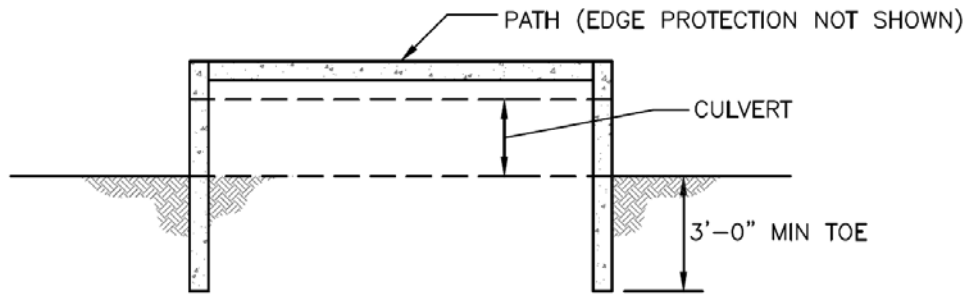
SECTION A1  
CROSSING WITH RUMBLE STRIP



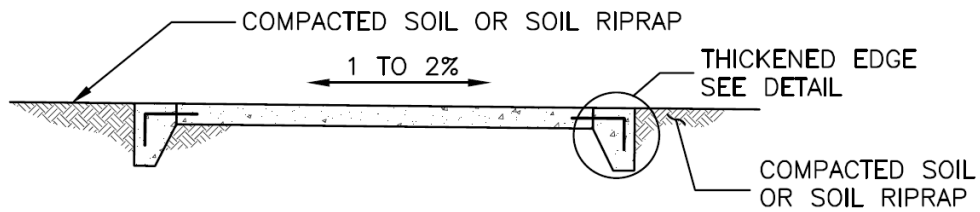
SECTION A2  
CROSSING WITH CURB RAIL



SECTION A3  
CROSSING WITH CULVERT AND RIPRAP



SECTION A4  
CROSSING WITH CULVERT AND HEADWALL



SECTION B  
OVERTOPPING PROTECTION

### 3.6.3 Equestrian Crossings

Horses are not always compatible with other types of path users and a separate tread for equestrian use, where practicable, is a good idea. This is especially true at crossings and underpasses where an animal may experience additional anxiety due to other users. When this is the case, equestrian crossings consist of a stabilized section of the stream marked for equestrian use. Equestrian crossings should consider safety for the horse. The smooth face of a horseshoe can cause a slip on a smooth hard surface such as concrete or metal especially when placed on a slope. Placement of an equestrian crossing is best where typical flows will be two feet or less and the channel is relatively straight. Equestrian crossings can be constructed by filling cellular confinement material with crushed rock. Use of geosynthetic materials (e.g., cellular confinement systems), in general, offers the desired surface for the animal while also providing the stability needed in areas of the path that are frequently wet (including crossings). Methods such as plating the channel with riprap (pushing riprap onto the channel bottom) and constructing a textured concrete (e.g., tooled joints similar to a rumble strip) crossing, such as the one shown in Photo 10-23, have also been used in the Denver Metropolitan area.

Smooth and hard surfaces become more dangerous on a slope. The Federal Highway Administration recommends that paths that have hard surfaces and slopes steeper than five percent need to be treated (e.g., terraced such as the crossing shown in Photo 10-24) to increase traction.



**Photograph 10-23.** An equestrian crossing parallels a separate multi-use crossing. Photo courtesy Arapahoe Park and Recreation District.



**Photograph 10-24.** Timber steps filled with roadbase are constructed to provide traction approaching a water crossing. Photo courtesy Arapahoe Park and Recreation District.

### 3.7 Material Selection

UDFCD has used several surfacing techniques for paths, including stabilized rock, reinforced grass, crusher fines, asphalt, concrete, and other proprietary surfaces. The following sections provide considerations for each.

#### 3.7.1 Stabilized Rock and Reinforced Grass Paths

Stabilized rock and reinforced grass paths are generally used for “maintenance only” paths. To avoid rutting, compact both the subgrade and rock and use a rock that is well graded. Road base works well in this application. As with all path materials, backfilling the edges after construction is recommended to help hold the material in place and reduce chance of injury.



**Photograph 10-25.** This stabilized rock trail was constructed for maintenance.



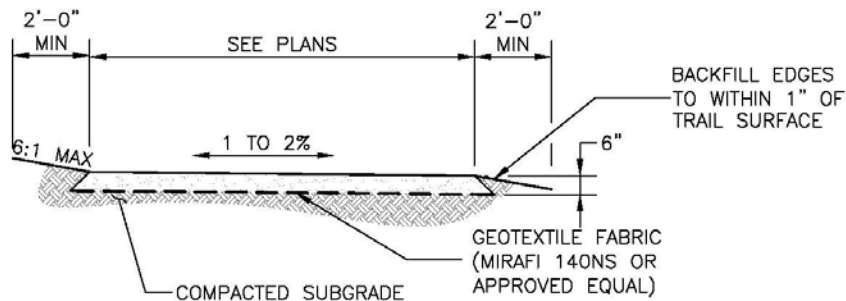
**Photograph 10-26.** Reinforced grass pavement shortly after construction.

### 3.7.2 Crusher Fines

Crusher fines are not recommended below the 10-year water surface elevation or where the longitudinal slope exceeds 5%. Crusher fines typically wash out when stream flow (or concentrated cross drainage) flow over the path. Provide a weed barrier over the subgrade when using crusher fines.



**Photograph 10-27.** Geotextile is all that is left of this crusher fines trail that washed out on Goldsmith Gulch.



**Figure 10-9. Crusher fines path section**

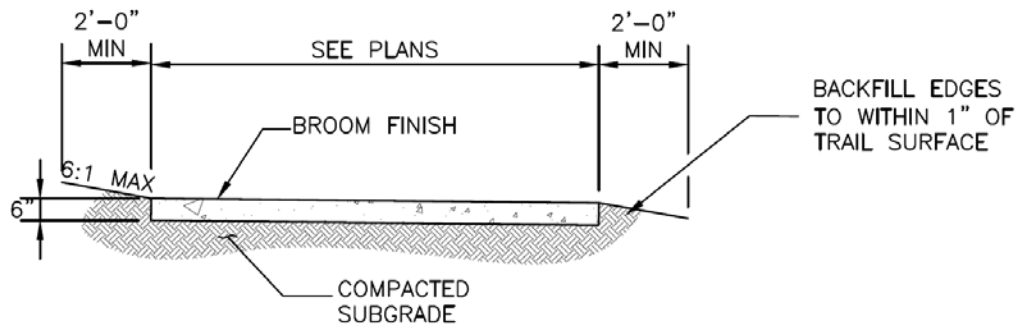
### 3.7.3 Asphalt

UDFCD no longer uses asphalt for path construction due to maintenance issues. Problems with this material near the stream include vegetation, both with tree roots damaging the pavement and with weed growth through the pavement. Cracking, especially near the edges of the pavement was also a significant issue. If used for this purpose an herbicide should be applied on the subgrade prior to placement.

### 3.7.4 Concrete

Concrete is the most common path material for shared-use paths. A 6-inch depth section of fiber-reinforced concrete on top of compacted subgrade is generally adequate depending on soil conditions and the types of vehicles anticipated. The concrete should be finished to provide a safe surface for the user. Broom finish is typical.

Control joints should be placed 10 to 12 feet on center. Hand-tooled joints are highly discouraged as they often catch debris. Provide expansion joints at all cold joints and locations where the path abuts another structure, (e.g., a low-flow culvert crossing or bridge abutment).



- NOTES:**
1. PROVIDE CONTROL JOINTS 10 TO 12 FEET ON CENTER.
  2. PROVIDE EXPANSION JOINTS AT ALL COLD JOINTS AND WHERE THE PATH ABUTS ANOTHER STRUCTURE.

**Figure 10-10. Concrete path section**

### 3.7.5 Proprietary Surfaces

Proprietary surfaces expand the range of alternatives available for the surface of the path and sometimes offer qualities not found in conventional surfacing. Use of proprietary surfaces on UDFCD-maintained streams is generally allowable when the surface provides a structurally sound, maintainable surface that allows for frequent inundation without requiring repair.



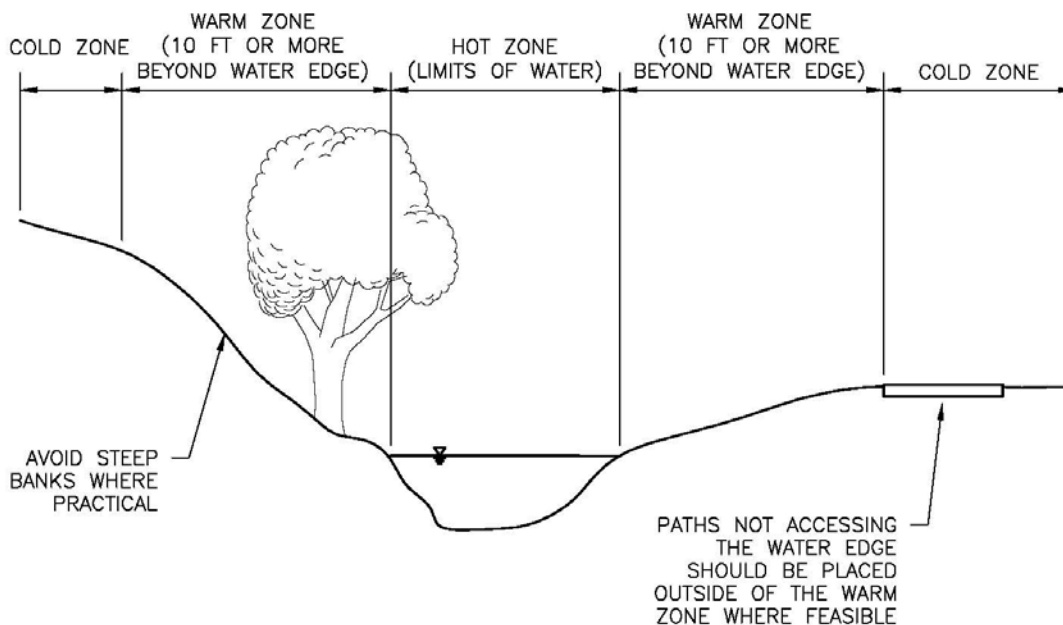
**Photograph 10-28.** StaLok® paving material, a proprietary surface consisting of resin bound gravel, has replaced failed portions of the crusher fines Goldsmith Gulch path.

## 4.0 In-Channel Safety

This chapter focuses on the safety of public users in or near the water in recreational channels. The term “in-channel users” refers to people that are in the water. Swift Water Rescue manuals often refer to this as the “Hot Zone”. In-channel users include recreational enthusiasts in river craft such as rafts and kayaks, tubers, anglers, waders, and swimmers. In-channel users also include personnel maintaining or operating various structures and facilities in and sometimes adjacent to channels. Observers or others within a recreational channel that accidentally fall into the water are also considered in-channel users. The area where such incidents can occur is referred to as the “Warm Zone” in Swift Water Training and has been typically identified as within 10 to 15 feet of the edge of the water.

Planning, design and construction of channels and related structures such as low-head dams, drop structures, bridges and armoring, mandate a standard of care consistent with common-sense safety concerns for the public that responsibly uses the rivers and waterways.

While the identification and nomenclature of zones used in Swift Water Rescue are used in this chapter, note that issues and criteria related to these zones in Swift Water Rescue manuals and training may be different than used in this chapter. Discussions within this chapter refer to planning and design issues in and around water in recreational channels and are not related solely to “rescue” or “swift water” conditions, i.e. rapids.



**Figure 10-11. Zones of operation**

In general, personal safety risks related to in-channel users include drowning, injury, and infection. These risks are primarily attributed to:

- An overly-retentive hydraulic jump (sometimes referred to as “submerged hydraulic,” “keeper,” or “drowning machine”);
- Impacts, blunt trauma, cuts, and abrasion;
- Ingestion of pathogens in water;
- Hypothermia;
- Infection from cuts and abrasions;
- Foot or extremity entrapment;
- Pinning or entrapment against or in an obstruction;

These risks are greatly increased if proper equipment is not correctly used by the in-channel user.

Channels and rapids, with or without man-made structures are inherently hazardous. There are inherent and unavoidable risks related to recreating in and around channels. A primary objective in the planning, design, and construction of structures is that:

*Structures should be designed and constructed so that they are predictable and without hidden or unobvious hazards to responsible users.* (Charlie Walbridge, Safety Chairman, American Whitewater).

## 4.1 Recreational and Boatable Channels

### 4.1.1 Recreational Channels

The design, planning, and construction of recreational channels should take into consideration the potential for unintended entry into the water. Therefore, some planning and design considerations outlined in the Boatable Channels section (Section 4.1.2) may need to be addressed in the planning and design of all urban channels. The degree of this consideration will depend on issues such as the volume of traffic around the water’s edge, adherence to the criteria presented in Section 3.0 of this chapter, frequency and flow rate, the presence of railings, and the resulting consequences of accidentally falling into the water. Safety considerations during dry conditions related to public access to the bottom of the channel should also be made.



**Photograph 10-29.** These rafters are running the largest and most turbulent hydraulic features ever constructed. However this feature has been successfully run by tens of thousands of recreationalist and is hailed by safety expert Charlie Walbridge. Photo courtesy of Thanis McLaughlin

Design and planning considerations for recreational channels should consider bank conditions and

conditions within the Warm Zone. Design channel banks to avoid hidden safety issues (e.g., tripping hazards) that could cause unintended entry into the water and provide egress for those who may accidentally fall into the water.

Safety considerations related to the presence of flowing water during flooding in the Cold Zone may also need to be made. Some of these issues are discussed in Section 3.0, Paths Adjacent to Streams.

#### **4.1.2 Boatable Channels**

Boatable channels are considered a sub-set of recreational channels. Planning and design considerations within boatable channels include but are not limited to: drop structures; whitewater recreational areas or other recreational whitewater features; bridge piers; all types of bank armoring; woody vegetation; debris and debris accumulation; jetties; bendway weirs; fish passages; intake structures; etc.

The design of these features and structures must avoid the development of overly-retentive hydraulic jumps, sharp edges, foot entrapments, restricted egress, and address other dangers listed in Section 4.3. Within this manual, the term “drop structures” includes grade control structures, low-head dams, boatable passage structures or chutes, recreational features which form holes or waves, and others described herein. Some of these considerations, albeit to a reduced level, may need to be addressed in recreational channels that are not considered boatable.



**Photograph 10-30.** Recreational users in personal water craft at Confluence Park and most other constructed features are more common than experienced boaters. Photo courtesy of Rick McLaughlin.



**Photograph 10-31.** Recreational whitewater features in rivers are used by both children and adults. Appropriate use of a river and proper gear can be encouraged through recreational and educational programs. Photo courtesy of Thanis McLaughlin.

## 4.2 Glossary of Related Terms

The following glossary is intended to improve consistency and accuracy in communications with the river recreating community. The reader should note that the definitions of all terms are not universally recognized within this specialized industry.

<b>Term or Abbreviation</b>	<b>Meaning</b>
Aggradation	Aggradation involves the raising of the channel bed elevation through sedimentation, an increase in width/depth ratio, and often a corresponding decrease in channel capacity.
Bed Load	Coarse sediment transported along the bottom of the river by saltation (hopping), sliding, rolling, etc.
Benthic Macro-invertebrates	Benthic Macroinvertebrates are small animals living among the sediments and stones on the bottom of streams, rivers and lakes. Insects comprise the largest diversity of these organisms and include mayflies, stoneflies, caddisflies, beetles, midges, crane flies, dragonflies, and others. Other members of the benthic macro invertebrate community are snails, clams, aquatic worms, and crayfish. They are extremely important in the food chain of aquatic environments as they are important players in the processing and cycling of nutrients and are major food sources for fish and other aquatic animals
Counter Weir	A counter weir is a secondary drop structure or armored channel section downstream of a drop structure, pool, or hydraulic disturbance. It is usually smaller than the upstream drop structure and maintains the elevation of the tailwater experienced by the upstream drop structure or other hydraulic disturbance. An end sill, as described in the <i>Hydraulic Structures</i> chapter, could also be used for this purpose. They are often placed at the downstream limit of the Recovery Pool.
Drop Structure	A constructed feature or structure in a channel that creates a downward step in the water surface and a resulting hydraulic jump downstream of the structure. These can typically have a hydraulic drop of one-half to eight feet. These structures can be used for a number of purposes including diversions, recreation, and stream stability. They can also be called grade control structures, diversions, low-head dams, weirs, or just drops. They are typically constructed of grouted boulders or sculpted concrete with additional concrete or sheet pile cutoff walls. Regarding recreational whitewater, a drop structure is a physical feature that forms a “wave” or “hole”, boat chute, whitewater park or whitewater feature.
Eddies	Eddies are usually formed downstream of an obstruction or curvature in a river or channel. Eddies swirl on the horizontal surface of the water. Typically, they are areas where the downward movement of water is partially or fully arrested and currents flow in an upstream direction – if slow enough, a nice place to rest or to make one’s way upstream.
Freestyle	Competitive event where boaters perform tricks on a “breaking wave” or “hole”.

Hole(s)	<p>A “hole” is formed when the supercritical jet on the downstream face of an obstruction within the channel is directed toward the invert within the formation of the hydraulic jump. This causes the surface water and the upper portion of the water column to flow back upstream toward the obstruction. A strong breaking wave (see below) is often confused with a hole. It differs from a hole in that the supercritical jet is lifted and directed within the upper portion of the water column within the initial formation of the hydraulic jump. The distinction between a hole and a breaking wave however is not consistently made within the whitewater community.</p> <p>In hydraulic design terms, it is a particular formation of a hydraulic jump (see below). In the design of man-made whitewater or other structures within a river or waterway, it is usually created by a drop structure or structure(s) that create a significant constriction in the channel. Holes in recreational structures are typically designed for entertainment and skill-building, places where paddlers use the features to perform various moves.</p> <p>Poorly designed holes can be dangerous. They can dramatically aerate the water, possibly to the point where they lose the capacity to carry watercraft. In overly-retentive holes or “keepers” (see below) a boater may become stuck in the recirculating water. Some of the most dangerous types of holes are formed by low-head dams (weirs), ledges, and similar types of obstruction. Low-head dams or other structures that form a uniform hydraulic with no irregular or weak point are particularly dangerous. Low-head dams are insidiously dangerous because their danger cannot be easily recognized by people who have not studied whitewater.</p>
Hydraulic	The term “hydraulic” refers to a hydraulic jump and is river recreationalist jargon sometimes used when referring to a “hole” or “wave.” It could also be used to describe a hydraulic formation known as a supercritical shock wave.
Hydraulic Drop	Sometimes referred to as just “drop”. The vertical distance between the upstream and downstream water surface elevation. This can be applied to a single feature or to multiple features within a river reach or whitewater course.
Hydraulic Jump	A hydraulic transitional formation that occurs between supercritical and subcritical flow. This occurs downstream of a constriction or Drop Structure when the fast flow collides with the slower moving flow in a downstream pool. It is commonly referred to by river recreationalists as a “hole”, “wave”, or “hydraulic”.
Keeper	See Overly-Retentive Hydraulic.
Overly-Retentive Hydraulic	A hydraulic condition –technically a specific form or a hydraulic jump –that can occur downstream of a natural or man-made feature (such as a low-head dam). This condition tends to trap boaters, swimmers, or other floating objects for an extended length of time. This condition can also be called a submerged hydraulic, keeper, reverse roller, drowning machine or a variety of negative descriptors followed by the term “hole” or “hydraulic”.
Play Boating	Recreational boating primarily for surfing and performing “tricks” on breaking waves or in holes. These are typically whitewater kayaks and canoes. This type

	of recreational use can also include surfing, standup paddle boarding, and body boarding.
Pillows	Pillows are formed when a large flow of water runs into a large obstruction, causing water to “pile up” or “boil” against the face of the obstruction. Pillows are also known as Pressure Waves.
Portages or Portage Paths	Portages or portage paths are land routes used by in-river users to bypass or avoid dams, drop structures, or other in-channel obstructions. Portages can also serve as “detours” around sections of water that in-river users choose not to run.
Put-in	A put-in is a formalized area that facilitates access of in-river users and their craft to enter the water. They are often located at the downstream end of a portage path or upstream of a reach of river that is commonly used by recreationalists.
Recovery Pool or Zone	A recovery zone or pool is a slow moving reach of the river immediately downstream of a drop structure, series of drop structures, or other challenging hydraulic feature that allows for recovery by recreational users.
Slalom	Competitive event where boaters negotiate gates suspended over the river for the fastest time.
Strainers	Strainers can be deadly obstacles within a boatable channel. Water passes through but solid objects like boats or people do not, similar to a kitchen strainer used to drain spaghetti or clean vegetables. A fallen tree or branch is the most common type.
Structural Failure	Movement of rock or structures that: 1) is unanticipated or 2) results in a condition that negatively impacts safety. Also see Tuning or Adjustments.
Submerged Hydraulic Jump	See Overly-Retentive Hydraulic
Take-out	A take-out is a formalized area where in-river users can exit the river with their craft. They are often located at the upstream end of a portage path or at the downstream end of a reach of river that is commonly used by recreationalists.
Tailwater	Tailwater is the downstream depth of the water in a channel relative to a particular feature or structure. Tailwater has a significant impact on the performance of a drop structure and the resulting hydraulic jump.
Tuning or Adjustments	Due to the complex nature of hydraulics and the use of irregular boulders, some adjustments to rock or structure is usually required after the initial construction and the river is observed to flow through the features. This is usually conducted at the direction of the designer shortly after the initial construction or after the first year or two of operations. Also see Structural Failure.
Wave(s)	Waves found in most man-made structures are formed similarly to holes and are sometimes referred to as a “hydraulic”. In hydraulic design terms, it is a formation of a hydraulic jump which is created downstream of supercritical flow. In the design of man-made whitewater or other structures within a river or channel, it is usually created by a drop structure or a structure which creates a

significant constriction in the channel. Waves are noted by a smooth upward sloping face as the flow enters the hydraulic jump. This “green water” at the upstream portion of the formation is followed by a crest and downward sloping face. A wave can have a significant amount of whitewater or “haystack” and appear similar to a hole. These are called breaking waves. Sometimes a particularly large wave will also be followed by a long series of waves or “wave train”. Waves in channels can also be created without the formation of a hydraulic jump.

### 4.3 Minimum Criteria

Within the UDFCD region, infrastructure typically meets or exceeds the criteria outlined in this section. There are, however, numerous examples elsewhere in the country where these criteria are ignored, posing danger to users. Here are some of the minimum design criteria for boatable and, in some instances recreational channels:

1. All drop structures, including recreational "wave" or "hole" features as described later in this chapter, are specialized drop structures and should be designed in accordance with appropriate recommendations, considerations, guidance and procedures established in the *Hydraulic Structures* chapter of this manual.
2. Drop structures or other recreational features in rivers or channels have been designed and constructed since the 1970s. They are “works of engineering” as they safeguard life, health, and property and promote the public welfare. They necessitate design work requiring intensive preparation and experience in the use of mathematics and the engineering sciences. Therefore, their construction must adhere to design drawings sealed by a registered professional engineer.
3. Drop structures made of “natural materials” such as boulders or riprap are still structures and are works of engineering. They must be designed in accordance with appropriate criteria within this manual.
4. Structures should withstand stream forces for all flows up to and including the 100-year flood. This is critical because structures that experience movement or failure can create hazardous or changing hydraulic conditions well after a flooding event. Typically, structural movement would occur during high flow events that preclude maintenance or repair of the structure and coincides with in-river recreation such as rafting and kayaking. Therefore, structures within boatable channels should be designed and constructed to survive flooding without change in hydraulic performance. It is sometimes advantageous, however, to plan and design adjacent landscaping and other features on the banks or uplands (that do not impact safety or that can be replaced or repaired during normal flows) for lesser flooding events.
5. When analyzing impacts on flood conveyance, caution should be taken to avoid accounting for flood conveyance areas within the channel cross-section that will not be effective during flooding events. These could include deep pools, eddies, or areas of the channel that will fill with sediment or cobble. If the design relies upon the depth of pools or effectiveness of various portions (particularly areas with slow moving water) of the channel cross-section for conveyance of flood flows, then multi-dimension hydraulic analysis or physical modeling may be needed. Design of new drop structures or modifications of existing drop structures for in-channel recreation should not negatively impact the regulatory floodplain, cause increased bank erosion, or create localized channel instability from deposition or scour.

## 4.4 Design Considerations for Structures and Features

The following considerations should be reviewed for boatable and, in some instances, recreational channels.

1. **Egress.** Provide multiple opportunities for egress from the channel – particularly in critical locations such as before and after rapids or drop structures.
2. **Create Opportunities for Self Rescue.** Avoid hydraulic and physical conditions that make it difficult for in-channel users to access the banks. For structures that significantly impair self rescue, consider sloped racks or sides and ladders or stairs.
3. **Sharp Edges.** Avoid sharp edges and protruding objects.
4. **Strainers.** Avoid the creation of “strainers” and the potential for debris to collect and act as such. Accumulation of debris may occur at bridge piers, intakes, railing, or other infrastructure and on woody vegetation, features used for fish habitat, or bank stabilization.
5. **Intakes and Screens.** Prevent accidental entry into gates or inlet works with bar racks or screens at intakes (headgates) and design for approach velocities so as not to create pinning hazards.
6. **Utilities and Apparatus.** Provide physical separation or barriers if practical and (at a minimum) warning buoys and signs when hydraulic grates or screens, sluice gates, etc. are accessible and present a hazard to in-channel users.
7. **Fish and habitat considerations.** When it is appropriate to provide fish passage within the reach, integral features that support both recreational use and fish passage or habitat are desirable.
8. **Safety Signage.** Include warning signs upstream of hazards (intakes, etc.) and at the start of a drop structure or a series of drop structures. Signs to advise positive actions, such as encouraging the use of proper equipment, are also prudent.

### 4.4.1 Pinning and Overhead Obstructions

To reduce the chance of an in-channel user being pinned or trapped on a grate, screen, rack, or other feature that could become a strainer, reducing velocities going through the screen or object (approach velocity) and increasing the velocities of the flow passing by the screen or object (sweeping velocity) can be effective methods of reducing these potentially dangerous conditions. Well documented limits on approach velocities for safety are not available. For relevance, maximum design values for approach velocities for fish can vary from 0.2 to 0.8 ft/sec while maximum design values for approach velocities to reduce accumulation of trash of 0.5 feet per second have been used by the USBR. Consider a maximum design value for approach velocities into a screen or grate, of 0.5 or 1.0 ft/sec to reduce pinning of in-channel users. Approach velocities used for a particular application can depend upon sweeping velocities, the frequency of recreational users, the velocity and direction of the upstream currents, and other factors. Means to evenly distribute the flow across the screen should be considered. Note that recommended approach velocities to grates, screens, or bar racks in boatable channels are typically less than recommended maximum design velocities through racks and grates used in the design of typical drainage infrastructure.

Overhead clearance at bridges, low water crossings, utility crossing, or other structures that span boatable channels or portions of boatable channels should be sufficient to reduce hazards to in-channel users. There are no widely accepted minimum design clearances for these types of boatable channels. Consider

a minimum clearance (freeboard) in the range of six feet from the water surface of the recreational flow range to the underside of an overhead structure. Lesser amounts of freeboard may be appropriate during flood conditions.

#### 4.5 Drop Structures

The following drop structure criteria are provided in addition to the criteria provided in the *Hydraulic Structures* chapter of this manual.

For the purposes of this chapter, the term “drop structure” refers to a constructed feature (or structure) in a channel that creates a downward step in the water surface and a resulting hydraulic jump downstream of the structure. These can typically have a hydraulic drop of as little as six inches or up to eight feet or more. These structures can be used for a number of purposes including diversions; various types of recreation including kayaking, paddle boarding, and swimming; river stability; and enhancement of habitat. Terminology for typical or specialized drop structures includes: grade control structures, control structures, holes, whitewater parks, boat chutes, diversions, low-head dams, weirs, riffles, glides, and sills. Regarding recreational whitewater, a feature or structure that creates a “wave” or “hole” is also considered a specialized drop structure.

Structures should be designed with carefully planned components that are consistent with recreational requirements for user safety. Drop structures in boatable channels should incorporate a boat chute, bypass, or full river passage to allow passage for boats. Intakes have been designed and operated successfully to create whitewater features and allow fish passage while keeping recreationalists out of the intake works. Engineers have used a wide variety of approaches depending upon site-specific requirements.



**Photograph 10-32.** The intake at Confluence Park, Denver is located on the side of the river opposite to where the whitewater bypass is located. In addition to this physical separation, buoys, two debris booms and a bar screen were included to help keep recreationalists away from the intake works. Photo courtesy of McLaughlin Whitewater Design Group.



**Photograph 10-33.** The intake works on the American River near Auburn, California relies on a submerged self-cleaning fine screen. The screen is located in the invert of a boatable channel. This design eliminates intake apparatus that can be hazardous to recreationists, screens for fish and solids, and has proven to require relatively little maintenance. Photo courtesy of Placer County Water Agency.

Warning signs and portage routes around such structures are appropriate in various situations. This chapter outlines some specific approaches and guidelines that have been used in past design efforts to reduce hazards of boatable drops. Boatable drop should be designed by professional engineers with experience with previously constructed projects that incorporate boatable elements, hydraulic modeling, scour analysis and floodplain regulations.

These are not the only approaches available to the engineer and do not address all issues. Design of drop structures intended to provide specific recreational attributes required for freestyle kayaking, slalom kayaking and canoeing may not follow all of the suggestions outlined in the Simplified Design Approach of the *Hydraulic Structures* chapter.

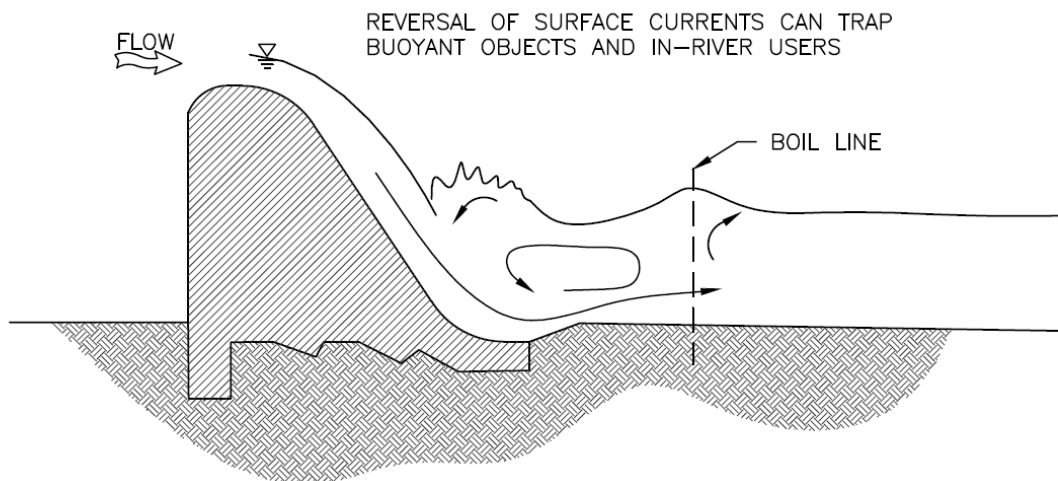
#### **4.5.1 Overly-Retentive Hydraulic Jump**

In whitewater river recreation, the characteristic for a hydraulic jump, referred to as a “hole” or “wave”, to keep a boat within a hydraulic jump is referred to as retentiveness. Retentiveness can be a desirable quality of a recreational wave or hole, but if the hydraulic jump is too retentive, it can hold swimmers or submerged craft. In this chapter, this dangerous hydraulic phenomenon is referred to as overly-retentive,

and the formation of overly-retentive hydraulics should be avoided. This hydraulic condition has a number of names including “submerged hydraulic jump,” “keeper,” “reverse roller,” and “drowning machine.”



**Photograph 10-34.** Currents downstream of dams or even drop structures can create an overly-retentive hydraulic jump that can trap in-channel users. Sometimes called “keepers” or “drowning machines,” these hydraulic conditions can be deceptively dangerous. The misleadingly dangerous structure shown here created this condition with only 1.5 feet of hydraulic drop before UDFCD retrofitted it to be safely boatable.



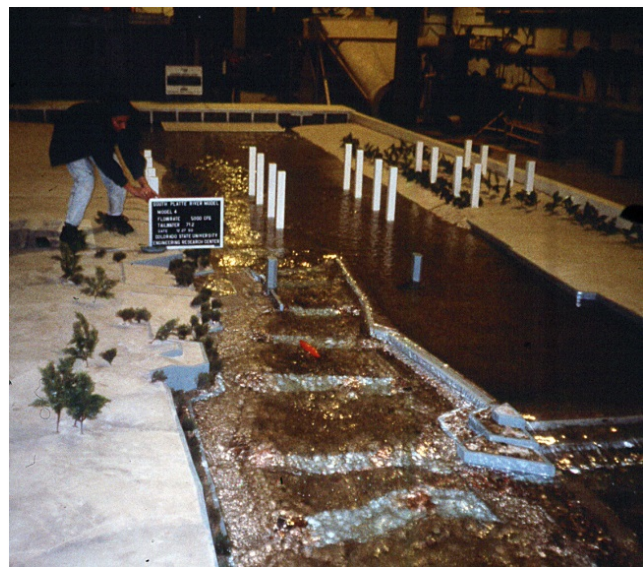
## OVERLY-RETENTIVE HYDRAULIC JUMP

SURFACE CURRENTS BELOW DAMS AND EVEN SMALL DROP STRUCTURES CAN CREATE AN OVERLY-RETENTIVE HYDRAULIC JUMP WHICH CAN BE WIDE AND UNIFORM ACROSS THE RIVER OR CHANNEL. THIS COMBINATION CAN CREATE CONDITIONS WHICH ARE DEADLY TO IN-RIVER USERS.

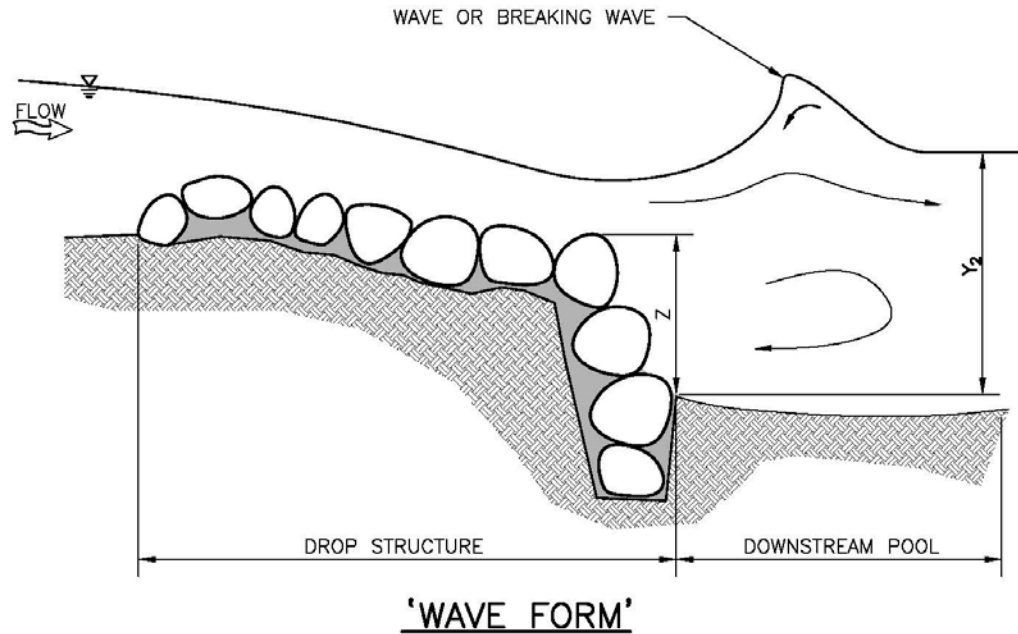
**Figure 10-12. Overly-retentive currents at a hydraulic jump**

One design approach to avoid an overly-retentive hydraulic jump is to direct the super-critical flow at a relatively flat angle. A downstream face on a drop structure having large grouted boulders and high roughness that is sloped at 10(H):1(V) has been used successfully on several projects in the UDFCD region. This slope should extend such that the jump occurs on the face of the drop structure.

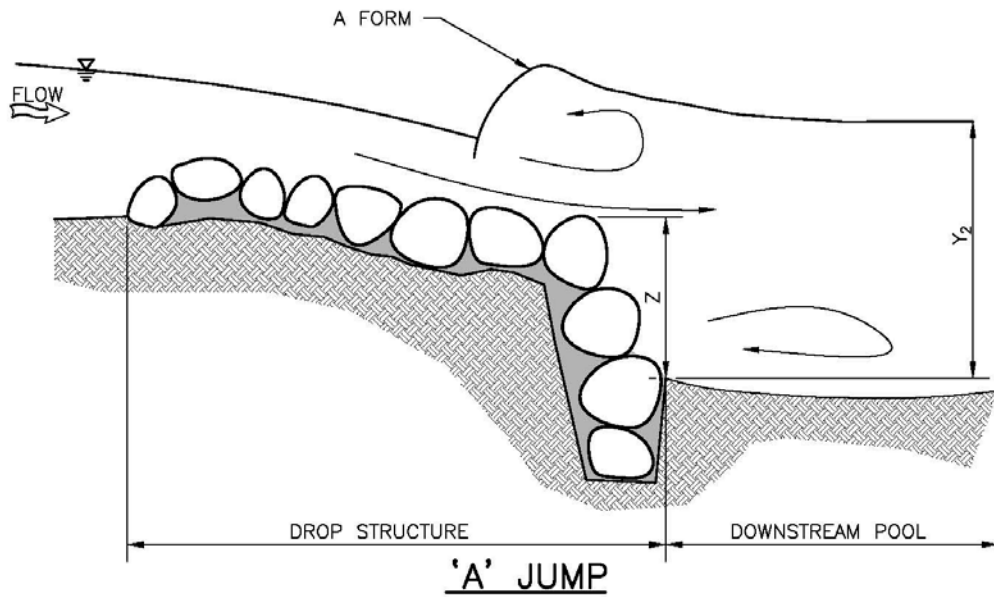
Other approaches have also been used to avoid the formation of overly-retentive hydraulics. The stepped dam at Confluence Park in Denver has demonstrated that a stepped configuration can also be an effective approach to avoiding an overly-retentive hydraulic jump. The formation of a hydraulic jump at an abrupt drop has also been used to effectively avoid the formation of overly-retentive hydraulic jumps over a wide range of river flows. (Samad, et.al, 1986)



**Photograph 10-35.** A physical model aided in the 1996 design of Confluence Park. This was one of the first whitewater venues to employ the hydraulic jump at an abrupt drop design. As a result, the venue performed well over a very wide range of flows for a diverse user group. Photo courtesy of McLaughlin Whitewater Design Group.

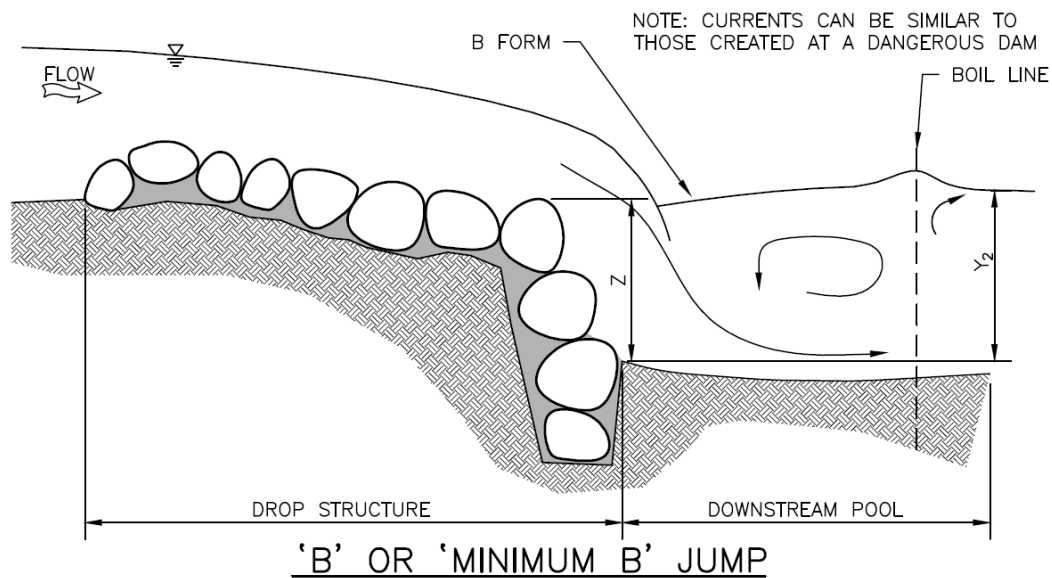


NOTE: THE WAVE FORM CAN CREATE FUN FEATURES THAT ARE NON-RETENTIVE AND LOW HAZARD



THE A JUMP IS CREATED IF THE TAILWATER IS HIGH AND IS USUALLY UNAVOIDABLE THROUGHOUT THE ENTIRE RANGE OF RIVER FLOWS. THIS CONDITION CAN BE SOMEWHAT RETENTIVE AND POWERFUL, BUT NOT NECESSARILY HAZARDOUS.

**Figure 10-13. Forms of a hydraulic jump at an abrupt drop**



THIS FORM CAN BE BENIGN OR CREATE A PLUNGING OR DIVING JET (AS ILLUSTRATED) THAT CAN BE OVERLY-RETENTIVE AND HAZARDOUS. THIS IS OFTEN CAUSED BY A LOWER THAN PREDICTED TAIL WATER ELEVATION ( $Y_2$ ) OR DOWNSTREAM DEGRADATION OF THE CHANNEL OR RIVER BED.

**Figure 10-13. Forms of a hydraulic jump at an abrupt drop (continued)**

#### Hydraulic Jump at an Abrupt Drop

Structures that employ a hydraulic jump at an abrupt drop have been effective in eliminating overly-retentive hydraulics. However, like many dams and drop structures, the elevation of the tailwater ( $Y_2$ ) is critical to the resulting hydraulic formation. Figure 10-13 shows hydraulic jump forms and nomenclature as outlined by Moore and Morgan (1959). The reader is referred to this paper and papers by Hsu (1950), Rajaratnam (1977), Ohitsu, (1990), and Samad (1986).

Even in recreational channels that are not boatable (e.g., often have little or no flow), drop structures should be designed so as to avoid the creation of dangerous hydraulic conditions. Smaller drop structures with a 4(H):1(V) downstream sloped face have been used successfully throughout the UDFCD region.

### 4.5.2 Design Approach

The following considerations are oriented toward providing simple recreational passage around or through a drop structure located within a boatable channel. Considerations and issues provided in this chapter and drop structure criteria presented in the *Hydraulic Structures* chapter are still applicable. Design of specialized recreational features, boatable features with integral fish passage, reaches where deposition of sediments or cobbles are an issue, or other applications requires the expertise of an experienced professional which is beyond the scope of this chapter.

1. Select the maximum hydraulic drop (different than drop height) — generally one to four feet. If the hydraulic drop is more than 4 feet, a physical hydraulic model may be necessary. Physical hydraulic models may also be useful to optimize recreational hydraulics or when a complex structure is needed in a highly used recreational area. Allow for longer recovery zones downstream of drops with larger hydraulic drops. (See item 3.g below.).
2. Determine the type of structure and passage to be used. Be aware that boatable structures can increase the cost of the project. Structure selection should always be based on safety first, but may also be based upon costs, aesthetics, floodplain issues, sediment transport, and river morphology. These types include:
  - a. **Full River Passage.** A structure or series of structures that span the entire channel width and are boatable throughout a range of flows, typical of most drop structures in Colorado that have been created primarily for recreational uses.
  - b. **Bypass.** A boatable path that flows to one side of a drop structure or low-head dam and is typically constructed when a larger or existing drop structure is encountered. Design of a bypass can be more complex and costly and may likely fall outside of what would be considered to be appropriate for “simplified” design as described in the *Hydraulic Structures* chapter.
  - c. **Boat Chute.** A localized passage through a drop structure such as at Alameda Avenue in Denver and at numerous locations along the South Platte River through the UDFCD region. These are often added to existing drop structures with the remainder of the drop structure not normally suitable for recreational passage.

When boat chutes or bypasses are employed, the drop structure or low-head dam is usually designed or modified with steps or other measures to reduce hazards associated with incidental passage. The stepped dam at Confluence Park is a successful example of this type of hazard reduction.

3. Determine basic drop structure characteristics to be compatible with public safety and recreational boating. Suggestions are as follows:

- a. Employ detailed multi-dimensional modeling or specialized design to avoid creation of an overly-retentive hydraulic condition:
  - i. Design for a Froude number of less than 1.5 at the toe of the drop.
  - ii. Use a downstream face slope no steeper than 10(H):1(V). This is particularly relevant during higher flow conditions.
- b. Extend the face of the drop 1 to 2 feet below the predicted range of tailwater elevations.
- c. Where tailwater elevations may decrease over time, consider use of a downstream grade control feature, sometimes referred to as a counter weir.
- d. Where the passage location will not be clear to the user based on site, inclusion of features to identify locations of passage — often pilot rocks, signs, or buoys may be appropriate. Pilot rocks should be spaced far enough apart and in a fashion to avoid collection of debris and to not create a blockage or hazard.
- e. Provide for energy dissipation downstream of the structure while maintaining structural stability of the drop structure, adjacent banks and adjacent structures such as bridges. Note that local scour depths downstream of various structures have been observed to be over ten feet.
- f. Provide a smooth invert — particularly toward the center of a drop to reduce abrasions and the potential for foot entrapment. Smooth inverts can be created by using rounded boulders, sculpted concrete, concrete, or high levels of grout.
- g. Provide a recovery pool of sufficient length downstream of each drop or a series of drops to allow for recovery of boaters that have capsized or otherwise lost control. The recovery pool should include eddies which can be formed by the drop, intermediate jetties, or other features.
- h. Provide portage facilities including signs, paths, jetties, pier noses
- i. and armoring to support ingress and egress over a wide range of flows.



**Photograph 10-36.** The stepped dam at Confluence Park was physically modeled at multiple flows up to the 100-year event. It was shown to not produce overly-retentive hydraulics throughout this wide range of flows. Photo courtesy of McLaughlin Whitewater Design Group.

- j. Consider the addition of anchor points to attach ropes strategically located near drop structures. These can be used by emergency personnel so they have something to connect onto during rescues or for removal of debris.
4. Obtain peer review of the preliminary and final designs.
5. Be onsite during placement of rock and features to reduce the occurrence of sharp edges and poor local hydraulic conditions. Be attentive to specific or nuanced placement detailed in drawings.
6. Plan for post-construction adjustment (tuning), adding or removing of boulders or portions of the structure after initial construction. Typically this would be conducted after a range of flows has been observed.

### 4.5.3 Retrofitting Existing Structures

When an existing dam or drop structure lacks features outlined in this chapter, retrofitting with portages, boatable passages, or other physical modifications may be needed. Retrofitting these structures may include installing a stepped or sloped surface along the downstream face of the dam or drop structure and providing appropriate barriers, signing and accessible portages with take-out and put-in landings. It may also include the addition of a boat chute or bypass to allow for passage of appropriate river craft. A structure that has too much drop may be replaced with two or more structures to reduce the drop at a single location. For example, replacing a 4-foot drop with two 2-foot drops could reduce a hazardous hydraulic condition.



**Photograph 10-37.** Pilot rocks can help recreationalists find a boat chute or preferred path through a drop structure. This is particularly helpful in wide rivers with a prominent horizon line. Photo courtesy of McLaughlin Whitewater Design Group.

Retrofitting dams or drop structures requires specific care to ensure that the retrofit meets the objective of improving public safety. Due to specific site and structure conditions, physical hydraulic models are sometimes appropriate in the design phase for retrofitting of dams and drop structures.

### 4.5.4 Integral Roughened Channel Fish Passage

Fish passage through drop structures can be critical in certain reaches of rivers and engineers should be alert to where they are needed. Fish passage usually refers to the ability of fish to swim upstream through the drop structure, but it can also include downstream passage of fish. The need and specific requirements can be established by the Colorado Parks and Wildlife, the US Fish and Wildlife Service, and other local governmental agencies. While identification of any regulatory requirements or project objectives should be established early, they can also arise through the USACE 404 permitting process. Where both fish passage and passage of in-channel users is desired, inclusion of integral fish passage features into boatable drop structures is preferred. Integration of these objectives into one passage usually results in a “roughened channel” type of fish passage, also referred to as rock ramps, natural fishways, riffle-pool fishways, and many others. Roughened channel fish passages can be readily included into boatable drop structures. In addition to fish passage at drop structures, recreational features and other infrastructure can

be designed to improve aquatic habitat.

Integrated features and objectives to improve habitat and provide for fish passage can include:

- Deep pools and thalwegs that are self-scouring,
- Resting areas,
- Creation of currents that encourage passage,
- Avoidance of depositions of fine or organic sediments,
- Avoidance of shallow zones to avoid bird predation,
- Creation of conditions conducive to benthic macroinvertebrates such as small sheltered spaces,
- Avoidance of fish stranding areas where rapid decreases in flows commonly occur, and
- Attraction flows that lead to the zones intended for upstream fish passage.

Care should be taken when incorporating the objectives above so that safety is not inadvertently impacted.

Criteria and objectives when fish passage is integrated into drop structures include:

- Selection of fish passage type and design to meet swimming capabilities and behaviors of target species,
- Maximum darting and sustained velocities,
- Maximum vertical drop heights, and
- Minimum depths.

Specific criteria depend upon the target species identified for passage and other factors. There are numerous agencies, publications, texts, and technical papers that can be used to establish criteria and provide design guidelines. Some of these include the US Bureau of Reclamation, the National Oceanic Atmosphere Administration (NOAA) in addition to the regulatory agencies listed earlier in this section. References for more detailed design/discussions include *Fisheries Handbook* (Bell 1991). In cases where fish passage or habitat is an important element or a permit requirement, it is best to include specialists in fish passage on the design team. However it should be recognized that the steepness, width, and depth criteria for whitewater boating can be compatible with those for fish passage.

Slopes of roughened channels or drop structures to meet fish passage objectives and criteria depend upon the target species, other related factors, and the size and configuration of the boulders that comprise the channel or slope of the drop structure. A typical range of slopes that have been used are 0.5 to 8 percent (Wildman, Parasiewicz, Katopodis, Dumont).

### 4.5.5 Supplemental Guidance for Drop Structures

In addition to the appropriate recommendations, considerations, guidance, and procedures established in the *Hydraulic Structures* chapter, and those outlined in this chapter, the following should be considered in the design and construction of boatable drop structures.

1. Determine and evaluate hydraulic conditions throughout the range of flows and tailwater elevations.
2. Allow for future downstream channel degradation and inaccuracies in estimation of tailwater elevations throughout the range of flows or consider the need for a downstream grade control structure (counter weir or small drop structure).
3. Include recovery zones or pools downstream of the drop structure where appropriate.
4. Avoid large recirculating eddies and enhance favorable swimming conditions to the banks to promote self-rescue.
5. Provide downstream bank protection as higher velocities can be carried farther downstream (compared to a conventional drop structure).
6. Include smooth invert in the areas where velocities are high, depths are shallow, and there is a concentration of boating traffic.
7. Incorporate features to address sediment and bed material transport and other dynamic river processes.
8. Observe performance over a range of flows after initial construction. Adjustments after initial construction (or *tuning*) are advantageous and often needed. This can include adding or removing boulders and grouting. This does not include rebuilding portions of the structure that have failed or replacing important boulders that have moved during high flows.



**Photograph 10-38.** Multi-use design of the whitewater bypass at Confluence Park conveys flood flows, offers continual access, and avoids overly-retentive hydraulic jumps over a wide range of flows. Photo courtesy of Thanis McLaughlin.

### 4.6 Bridge Piers or other Steep-Sided Structures

Clear span bridges are preferable but may be cost prohibitive. Where practicable, keep piers out of the floodway and main channel corridor. Often two piers, one at each bank, are preferable to one pier in the center of the channel. However, piers with debris accumulation located near the toe of a steep-sided bank can be a hazard and may trap rafts between the bank and pier.

Efforts should be made to reduce the chance of pinning, broaching, or wrapping on bridge piers or other vertical or near vertical midstream obstructions, especially where approach velocities are high. Piers can be made less hazardous by extending them or their noses upstream of the bridge deck into less constricted portions of the channel where velocities may be lower. Design of piers or features that reduce the accumulation of debris without creating other hazards should be investigated.



**Photograph 10-39.** The “pier nose extensions” on this bridge reduce the accumulation of debris and thereby improve safety for in-river users. Photo courtesy of McLaughlin Whitewater Design Group.

#### 4.7 Access and Portages

Egress from the water in a boatable channel should be evaluated by the design professional and impediments in critical areas avoided where practical.

Provide pathways (portages) around all drop structures, even if designed for boat passage, and around potentially dangerous obstructions or hydraulic conditions. Consider the use and maintenance of a buoy system upstream of these areas. Portages around boatable drop structures provide alternative route for those who do not wish to run whitewater due to hazardous flow conditions, presence of debris, or other reasons.

Portages should include an appropriately located “take-out” with slow velocities throughout a range of flows, such as an eddy. A jetty can be used to create an eddy or provide slow currents for access and portages as well as provide bank stabilization benefits. Locate take-outs and associated signage sufficiently upstream of a structure or obstruction. Design take-outs to resist local scour. Locate the downstream “put-in” far enough from the structure to avoid potential hazards associated with a range of flow conditions. For non-boatable structures such as dams, state or federal regulations may govern the boating exclusion zone upstream and downstream. These exclusion zones set the minimum distance from the dam or non-boatable structure to the beginning and endpoints of the portage path.



**Photograph 10-40.** Buoys upstream of Confluence Park Dam guide recreationalists away from the downstream dam and intake. Photo courtesy of McLaughlin Whitewater Design Group.



**Photograph 10-41.** This sculpted concrete jetty forms a small eddy downstream to enhance access to the river. The sculpted concrete surfacing also provides for direct access into the water’s edge. Photo courtesy of McLaughlin Whitewater Design Group.

Improved access benefits all users. Accessibility standards for the pathways and facilities adjacent to the water are triggered by project funding from or use of lands of Federal, State or local governments. It should be noted that there are no accessibility standards for hand carried boat launches at the point at which the water is accessed; however, there are accessibility standards applicable to the pathways and facilities leading up to the water's edge.



**Photograph 10-42.** This access ramp was designed with universal access in mind. Photo courtesy John Anderson.

Guidance for universal design that works well for most people, including individuals with physical disabilities, should be reviewed. See the user accessibility guidance provided in the River Management Society and National Park Service publication titled *Prepare to Launch!* Most recent larger recreational venues with whitewater features incorporate improvements that provide better access for all. Access improvements and equipment to facilitate rescue personnel should be located in close proximity to drop structures and recovery zones where practical.

Recommendations for accessible portage paths and ingress and egress points include:

- Avoid longitudinal grades that exceed 1:12 for short rises and 1:20 for longer rises where practical. This is typically most challenging at points of entry and exit to and from the water.
- Provide durable, permanent, nonslip paving material capable of withstanding locally high water velocities without damage or undercutting.
- Provide a cross slope of no more than 2%.
- Avoid use of guard railings where practical as they tend to be damaged by flood waters and accumulate debris. Accordingly, avoid abrupt drop offs or excessively steep grades adjacent to paths. Where local conditions require guards within the floodway, consider solid, durable walls instead of open-work railings.
- Site the portage path above the one-year flood level where practical.

Access for the disabled is governed by the Architectural Barriers Act of 1968 (ABA, triggered by Federal funding of programs and facilities) the Americans with Disabilities Act of 1990 (ADA, applicable to facilities for public accommodation) and Section 504 of the Rehabilitation Act of 1973 (programs or activities that receive Federal funds). The applicability of these standards and guidelines for access to the disabled to a project should be researched by the design professional. The guidelines and recommendations above are not substitutes for this research. See the inset on the following page for resources pertaining to accessibility.

**Accessibility Resources and Guidelines**

ABA Accessibility Standards ([www.access-board.gov](http://www.access-board.gov))

ADA Accessibility Standards for Accessible Design ([www.ada.gov](http://www.ada.gov))

American Canoe Association (ACA)

American Trails, Resources and Library

*2010 ADA Standards Excerpts for Recreational Boating Facilities*, California Department of Boating and Waterways (2013)

*Best Management Practices*, Western Wood Preservers Institute

*Designing Accessible Launches in Accordance with Americans with Disabilities Act Accessibility Guidelines*, National Park Service

*Environmental and Aesthetic Impacts of Small Docks and Piers*, NOAA Coastal Ocean Program

*Floating Trail Bridges and Docks*, US Forest Service

*Guidance on the 2010 Standards for Accessible Design*, Department of Justice

*Guidelines for Developing Non-motorized Boat Launches in Florida*, Florida Fish & Wildlife Conservation Commission

*Guidelines for Public Safety At Hydropower Projects*, Federal Energy Regulatory Commission

*Hydropower Relicensing, Recreational Liability, and Access*, American Whitewater

*Iowa Water Trails Toolkit*, Iowa Department of Natural Resources

*Layout, Design and Construction Handbook for Small Craft Boat Launching Facilities*, California Department of Boating and Waterways

*Non-Motorized Boating in California* (see Table 3.1: Overview of Key Facility Needs by Non-Motorized Boat Types in California)

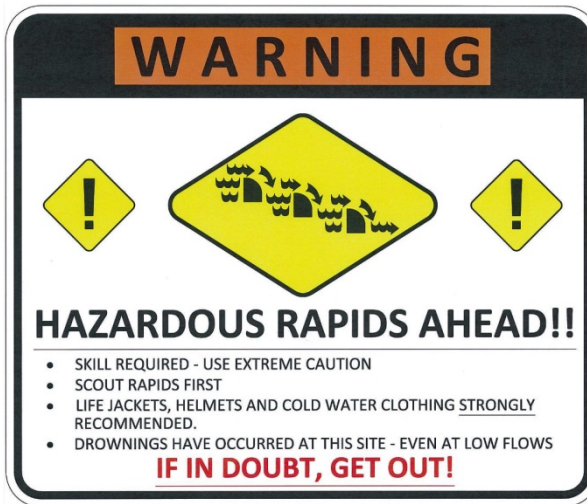
*Prepare to Launch! Guidelines for Assessing, Designing and Building Access Sites for Carry-in Watercraft*, River Management Society and National Park Service

*Streambank Revegetation and Protection: A Guide for Alaska*, Alaska Department of Fish & Game

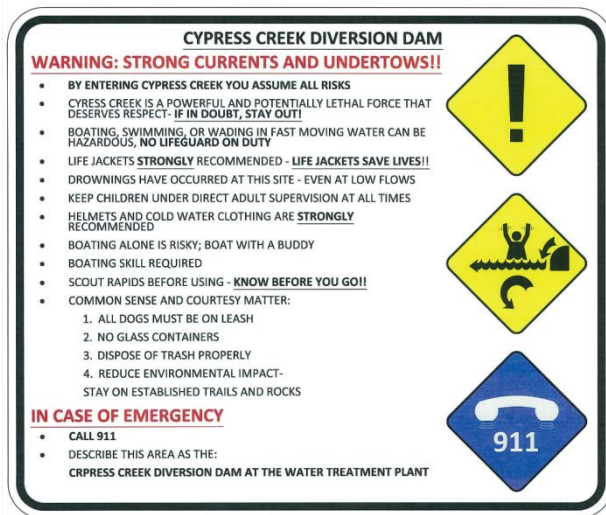
*Wetland Trail Design and Construction*, US Forest Service

## 4.8 Safety Signage

In addition to responsible design, signage should be provided at locations where public use is intended near hydraulic structures and where hazards are not obvious to the responsible user. Warning signs for dams or drop structures that are to be avoided (i.e., having no passage) are critical. There are a number of signage examples and guidelines across the United States.



**Photograph 10-43.** Signage prior to a boatable diversion in Florence Alabama. Courtesy of McLaughlin Whitewater Design Group.



**Photograph 10-44.** Additional signage placed adjacent to the facility in Florence Alabama. Photo courtesy of McLaughlin Whitewater Design Group.

There are currently no widely accepted standards for warning signage at river parks or boatable drop structures. One of the primary safety concerns is the prevalence of users without approved lifejackets, or Personal Floatation Devices (PFDs). Signage that emphasizes the need for PFDs is of utmost importance.

Signage wording should be reviewed by persons knowledgeable with both effective signage and river-related activities. Some considerations for wording include:

- Warning: Strong Currents and Undertows — Life Jackets Required
- Use Helmets and Cold Water Clothing
- Emergencies Call 911 (and/or provide phone number of fire department)
- Rapid Ahead - Scout Before Using (place upstream of portage)
- Skill Required
- Paddle Responsibly
- Bank Drops Off Quickly
- Don't Go in the Water Alone
- Keep Children Under Direct Adult Supervision at All Times
- Drownings Have Occurred at This Site — Even at Low Flows

- Use at Your Own Risk

Signage to warn in-channel users of poor water quality, especially during wet-weather flow in urban areas, may also be appropriate.

Efforts to develop more universally accepted recommendations and suggested wording are being considered by several entities but do not exist at the time of publishing this manual. Some examples of signage are included in Chapter 7 of the Colorado Water Conservation Board's (CWCB) Floodplain and Stormwater Criteria Manual.

#### **4.9 Maintenance Considerations**

Maintenance of boatable channels is important to avoid accumulation of debris that could create a strainer and to identify any rock movement or structural issues that could create hazardous conditions. Improvements should be planned, designed, and constructed to avoid excessive maintenance requirements. Potential areas of sediment deposition resulting in aggradation or areas that accumulate debris, particularly in pools or zones with low velocities, should be identified. Maintenance needs and frequency of cleaning should be roughly approximated in the planning and design process. Paths, grading, and other ancillary infrastructure or considerations should be included to facilitate identified maintenance needs.

## 5.0 References

- American Society of Civil Engineers and Water Environment Federation (ASCE and WEF). 1992. *Design and Construction of Urban Stormwater Management Systems*. American Society of Civil Engineers Manuals and Reports of Engineering Practice No. 77 and Water Environment Federation Manual of Practice FD-20. New York: ASCE.
- American Society of Civil Engineers (ASCE). 2014. *Public Safety Guidance for Urban Stormwater Facilities*. New York: ASCE.
- Bell, Milo. 1991. *Fisheries Handbook* United States Army Corps of Engineers North Pacific Division.
- Hsu, E.Y. 1950. *Discussion of Control of the Hydraulic Jump by Sills*, by John W. Forster and Raymond A. Skinde. Transactions, ASCE, Vol. 115, pp. 988-991.
- McLaughlin, R; Grenier, R 1996 Low-Head Drop Structure Hazards; Modeling of an Abrupt Drop Chute. Hydraulic Engineering Volume I, pp. 714-721; Proceedings of the American Society of Engineering Hydraulics Division, National Conference, August 4-6, 1996, Long Beach, CA
- Moore, Joe. *Paddlesports Launch Site Accessibility – Legal Compliance and Beyond*. 2014 River Management Society (RMS) Conference, Denver, Colorado. April 2014
- Moore, Joe. Personal interview by Richard McLaughlin. April 2014. American Canoe Association.
- Moore, W.L. and Morgan, C.W. 1959, *Hydraulic Jump at an Abrupt Drop*, Transactions, ASCE, Vol. 123, pp. 507-516.
- Ohitsu, I., Yasuda, Y , 1990, *Transition from supercritical to subcritical flow at an abrupt drop*. *Journal of Hydraulic Research*, Vol. 29, No. 3.
- Rajaratnam, N and Ortiz, N.V. 1977 *Hydraulic Jumps and waves at Abrupt Drops*, Journal of Hydraulic Division, ASCE Vol. 103, No. HY4, pp. 380-393.
- Samad, M.A. Pflaum, J.M., Taggart, W.C., McLaughlin, R.E. 1986. *Modeling of the Undular Jump for Whitewater Bypass*, Proceedings of the 1986 National Conference, ASCE, pp. 714-721.
- Shimoda, Risa. River Management Society. Personal interview by Richard McLaughlin. 2014
- U.S. Department of the Interior, Bureau of Reclamation. 2006, *Fish Protection at Water Diversions; A Guide for Planning and Designing Fish Exclusion Facilities*, Water Resources Technical Publication.
- U.S. Department of Transportation Federal Highway Administration, July 1999. *Designing Sidewalks and Trails for Access*.
- U.S. Department of Transportation Federal Highway Administration, last modified April 23, 2011. *Equestrian Design Guidebook for Trails, Trailheads and Campgrounds*.
- Wildman, Laura, Parasiewicz, Piotr, Katopodis, Christos, Dumont, Ulrich *An Illustrative Handbook to Nature-Like Fishways – Summarized Version*
- Wright, K. R., T. A. Earles and J.M. Kelly, 2003 *Public Safety at Low-Head Dams*, Proceedings, Dam Safety, Annual Conference Proceedings, Minneapolis, MN, Sept. 7-10, 2003, Association of State Dam

Safety, Officials (ASDSO), 14 pp.

Zeller, Janet. April 2014, Personal *communications regarding universal accessibility*. Janet Zeller, U.S. Forest Service, National Accessibility Program Manager, Washington, U.S. Forest Service.

Urban Storm Drainage Criteria Manual  
VOLUME 2, CHAPTER 11

# CULVERTS AND BRIDGES

November 2025

**MHFD**  
MILE HIGH FLOOD DISTRICT

# CHAPTER 11: CULVERTS AND BRIDGES

## Table of Contents

<b>1.0</b>	<b>Introduction and Overview</b>	<b>1</b>
<b>2.0</b>	<b>Required Design Information</b>	<b>3</b>
<b>2.1</b>	<b>Planning</b>	<b>3</b>
2.1.1	Drainage Master Plan	3
2.1.2	Safety	3
2.1.3	Structure Selection Report	4
2.1.4	Location and Alignment	5
<b>2.2</b>	<b>Environmental Permitting</b>	<b>5</b>
2.2.1	Wetlands	5
2.2.2	Floodplain Permitting	5
2.2.3	Construction Dewatering	5
2.2.4	Stormwater Permitting	6
2.2.5	Aquatic Organism Passage	6
<b>2.3</b>	<b>Hydrology &amp; Hydraulics</b>	<b>8</b>
2.3.1	Design Flood Frequency and Discharge	8
2.3.2	Allowable Headwater Depth for Culverts	8
2.3.3	Tailwater Depth for Culverts	9
2.3.4	Allowable Outlet Velocity for Culverts	9
2.3.5	Culvert Design Details	10
<b>3.0</b>	<b>Culvert Hydraulics</b>	<b>12</b>
<b>3.1</b>	<b>Key Hydraulic Principles</b>	<b>12</b>
3.1.1	Energy and Hydraulic Grade Lines	13
3.1.2	Inlet and Outlet Control	14
<b>3.2</b>	<b>Energy Losses</b>	<b>17</b>
3.2.1	Inlet Losses	17
3.2.2	Friction Losses	18
3.2.3	Outlet Losses	19
3.2.4	Total Losses	19
<b>4.0</b>	<b>Culvert Sizing and Design</b>	<b>20</b>
4.1	HY-8	20
4.2	HEC-RAS	20
4.3	Design Considerations	21

4.3.1	Culvert Profile	21
4.3.2	Minimum Culvert Diameter	21
4.3.3	Limited Headwater	21
4.3.4	Culvert Outlet	22
4.3.5	Minimum Velocity	22
4.3.6	Culvert Shape	22
<b>5.0</b>	<b>Culvert Inlets</b>	<b>23</b>
5.1	Types of Inlets and Appurtenant Structures	25
5.1.1	Headwalls	25
5.1.2	Wingwalls	25
5.1.3	Aprons	26
5.1.4	Special Inlets	26
5.2	Inlet Protection	30
5.2.1	Debris Management	30
5.2.2	Buoyancy	31
5.3	Safety Grates	31
5.3.1	Culvert Entrances with Design Flows up to 300 CFS	32
5.3.2	Design Flows Exceeding 300 CFS including Box Culvert Entrances	33
5.3.3	Outlet Grating	35
5.3.4	Collapsible Grating	36
5.3.5	Upstream Debris Collectors	36
<b>6.0</b>	<b>Outlet Protection</b>	<b>37</b>
<b>7.0</b>	<b>Bridges</b>	<b>38</b>
7.1	General	38
7.2	Backwater and Hydraulic Analysis	39
7.3	Freeboard	40
7.4	Bridge Scour Analysis	40
<b>8.0</b>	<b>Design Example</b>	<b>43</b>
<b>9.0</b>	<b>Culvert Checklist</b>	<b>46</b>
<b>10.0</b>	<b>References</b>	<b>47</b>

## Figures

Figure 11-1. Illustration of terms for open channel flow	13
Figure 11-2. Illustration of terms for closed conduit flow	14
Figure 11-3. Inlet control – unsubmerged inlet	15
Figure 11-4. Inlet control – submerged inlet	15
Figure 11-5. Outlet control – partially full conduit	16
Figure 11-6. Outlet control – full conduit	16
Figure 11-7. Inlet with headwall and wingwalls	25
Figure 11-8. Typical headwall-wingwall configurations	25
Figure 11-9. Examples of side-tapered and slope-tapered improved inlets	29
Figure 11-10. Conceptual MHFD Safety Grate	35
Figure 11-11. Hydraulic cross section locations (Source: HEC-RAS Hydraulic Reference Manual)	39
Figure 11-12. Cross section locations and ineffective flow areas (Source: HEC-RAS Hydraulic Reference Manual)	40
Figure 11-13. Example of scour envelope, as calculated with HEC-RAS (Source: HEC-RAS Hydraulic Reference Manual)	41
Figure 11-14. Adding a crossing in HY-8	45
Figure 11-15. HY-8 output	45

## Tables

Table 11-1. Maximum headwater depth to culvert diameter (or height) ratios (HW/D) (CDOT, 2019)	9
Table 11-2. Manning’s roughness coefficients for common culvert materials	13
Table 11-3. Entrance loss coefficients (FHWA, 2012)	24
Table 11-4. Types of safety grate required for circular pipes of varying diameters and headwater to depth ratios (HW/D)	32
Table 11-5. HY-8 program inputs	44

# 1.0 INTRODUCTION AND OVERVIEW



**Photograph 11-1.** Single-cell box culvert structure with recreational path set above minor flood elevation

This chapter addresses the hydraulic function of culverts and bridges, which provide conveyance of surface water through embankments such as roadways and railroads. Structural and geotechnical considerations, such as the design requirements to support loads, are not addressed in this chapter. This chapter primarily focuses on design of culverts (Photograph 11-1) and includes a brief overview of considerations related to bridges. When designing a culvert or bridge that will include a shared-use path, also see the *Stream Access and Recreational Channels* chapter of the Urban Storm Drainage Criteria Manual (USDCM).

A careful approach to designing culverts and bridges is essential, because crossings often significantly influence upstream and downstream flood risks, floodplain management, and public safety. Multiple factors affect the hydraulic capacity and overall performance of a culvert or bridge. These include the size, shape, slope, material, inlet configuration, outlet protection, and other variables. Sizes and shapes of culverts vary from small circular pipes to large arch sections used in place of a bridge.

In addition to the primary function of conveying flow, culverts may create conditions upstream that are suitable for wetland growth (Photograph 11-2). This may create additional maintenance needs to manage sediment and vegetation but also provides ecological value.

Incorporate aesthetic considerations and landscaping into designs to integrate the culvert or bridge with the surrounding landscape. This can be achieved through thoughtful grading, landscaping, and wall design, including finishing.

The Federal Highway Administration’s (FHWA’s) *Hydraulic Design of Highway Culverts*, Hydraulic Design Series No. 5 (HDS 5, FHWA, 2012) provides much of the information needed to design culverts according to the procedures in this chapter. The Colorado Department of Transportation’s (CDOT’s) *Drainage Design Manual, Chapter 9: Culverts* also provides information on design criteria and procedures, largely following HDS 5 (CDOT, 2019). This chapter provides examples of some of the most common culvert scenarios; however, this chapter does not republish many of the nomographs, equations, and technical background provided by FHWA’s HDS 5 since it is readily available on the internet. Refer to this FHWA publication for special cases, larger culvert sizes, or specific technical topics not covered in this chapter.

Bridge design criteria are provided by a series of FHWA publications listed in Section 7.0. CDOT’s *Drainage Design Manual, Chapter 10: Bridges* also provides information on design criteria and procedures, largely following FHWA methods (CDOT, 2019).



**Photograph 11-2.** Culverts frequently provide compatible conditions for upstream wetland growth.

### Definitions of Culverts and Bridges

A **culvert** is any structure not classified as a bridge, that provides an opening under a roadway, or other types of access or utility. A culvert is defined as the following:

- A structure that is usually hydraulically designed to take advantage of submergence to increase hydraulic capacity;
- A structure used to convey surface runoff through embankments;
- A structure, as distinguished from bridges, usually covered with embankment and composed of structural material around the entire perimeter, although some are supported on spread footings with the streambed serving as the bottom of the culvert; and
- A structure that is 20 feet or less in centerline span-width between extreme ends of openings for multiple boxes. However, a structure hydraulically designed as a culvert is treated as a culvert in this chapter, regardless of its span.

**Bridges** are legally defined (23 CFR 650.403) as structures with a centerline span of 20 feet or greater; however, this legal definition is primarily used to identify structures that are subject to federal inspection oversight rather than to distinguish between bridges and culverts. Structures designed hydraulically as culverts are treated as culverts in this chapter regardless of the span-width. CDOT uses the 20-foot width threshold to distinguish between minor structures (less than or equal to 20-foot span) and major structures (greater than 20-foot span).

The decision between using a large culvert structure or a bridge to span a stream must consider multiple factors, including (but not limited to) safety, cost, aesthetics, maintenance, environmental, and structural factors. The hydraulic analysis of alternative structures aids in this decision (CDOT, 2019).

## 2.0 REQUIRED DESIGN INFORMATION

For hydraulic design of a culvert or bridge, consider the factors detailed in this section at a minimum. Culvert and bridge projects also require structural, geotechnical, transportation engineering, and landscape architecture, which are beyond the scope of this chapter. Use a multi-disciplinary design team including these area of expertise to ensure all aspects of the design have appropriate attention.

### 2.1 PLANNING

#### 2.1.1 Drainage Master Plan

Determine how the proposed structure fits into the relevant drainage master plans and evaluate if there are other community objectives (recreational access, etc.) in addition to conveyance to consider. For example, box culverts can also serve as below-grade crossings, with one cell elevated to act as a pedestrian underpass during dry weather and more-frequent storm events, while conveying flows only during larger storm events. (see the *Stream Access and Recreational Channels* chapter for criteria). Additionally, a culvert can be used to discharge at a controlled flow rate while the area upstream from the culvert is used for flood detention storage to attenuate runoff. In such a case, the embankment that the culvert penetrates should effectively be designed as a dam.

Verify that upstream and downstream property owners are not adversely affected by changes in hydraulic conditions. When restricting flow to attenuate major events, evaluate the area of potential flooding upstream of the new culvert. If a culvert is replaced by one with more capacity, evaluate the downstream effects of the increased flow. Ensure consistency with existing Mile High Flood District (MHFD) planning studies.

#### 2.1.2 Safety

Hydraulics at culverts and bridges have the potential to create safety hazards. As a part of planning and design, the engineer must evaluate the safety of the structure in the context of the surroundings. As examples:

- Are there specific public safety issues related to the culvert or bridge location, such as proximity to parks or other public areas that have a bearing on the structure design? For culverts, a key question is whether or not to include a safety/debris grate at the culvert inlet (grates should be avoided at culvert outlets). See Section 5.3 for further discussion of safety grates.
- Culverts often are located at the bottom of steep slopes. Large culvert openings, in particular, can create a potential falling hazard, which poses risk to the public. Consider what the area looks like when flooded and if areas exist where a person or vehicle may unknowingly enter deep water. In such cases, fencing (or guardrails for roadway applications) is recommended for public safety.
- Understanding where runoff will go when the roadway overtops is a critical safety consideration. In some cases, the low point of the road may be in a different location than the culvert, which can result in flooding of areas outside of the regulatory floodplain, which is typically defined based on clearwater flows with unobstructed culverts and bridges. This is critical analysis for culverts that are designed to overtop on to the street above a certain design event and for culverts in areas where debris blockage may potentially occur. Evaluate the overflow path for stability under overtopping conditions and provide armoring to minimize potential for erosion. Two-dimensional modeling may be needed to evaluate complex overland flow paths.

- To reduce the potential for urban camping in culverts and bridges that have concealed areas, keep entrances and exits unobstructed and visible from the banks upstream or downstream of the culvert. Manage vegetation so that entrances and exits are not obscured and provide maintenance access to allow for inspection of the culvert. Activating the area by incorporating a pedestrian trail may also help to reduce the potential for urban camping. Visibility and activity are two of the best ways to minimize urban camping. See section 5.3 when considering the installation of a safety grate to discourage urban camping.

### 2.1.3 Structure Selection Report

When a structure will span more than 20 feet, prepare a Structure Selection Report (SSR) to provide the rationale for selecting a culvert over a bridge, or vice versa. The SSR documents key factors – including site requirements, public safety, and hydraulics – that inform the recommended selection for a major drainageway crossing.

Examples of structure types include reinforced concrete box culverts (RCBCs), concrete arch culverts, and bridges with piers. Examples of configuration parameters may include the number of cells, openings, and/or piers, and the relative inverts of each. Examples of dimensions may include the diameter or width and height (for culverts) or the opening widths and pier diameters (for bridges).

#### Structure Selection Report

When developing a SSR, follow guidance in CDOT's Drainage Design Manual, Chapter 4: Documentation (CDOT, 2019) and CDOT's Structure Selection Report QA Checklist (CDOT, 2023). For projects involving local (non-federal/non-state) road crossings of major drainageways, provide the following at a minimum:

- Location and vicinity map.
- Description of the existing structure, if applicable.
- Required roadway cross section based on roadway classification, along with the horizontal and vertical alignment.
- Required accommodation for grade-separated regional trails under the deck.
- Discussion of traffic impacts during construction, if applicable.
- Discussion of utilities and potential conflicts.
- Discussion of hydraulics, including design flows, geomorphic and sediment transport considerations, and regulatory impacts.
- Discussion of environmental concerns.
- Discussion of geotechnical concerns. A geotechnical report addressing these matters is required.
- Discussion of selection criteria, which should be based on the preceding information.
- Development and evaluation of several viable alternatives for the proposed crossing.
- Cost estimates for each alternative.
- Recommendation of a structure based on the selection criteria.
- Conceptual drawings of the selected structure. Drawings should fully define the geometry of the structure but need not include structural details or reinforcement.

## 2.1.4 Location and Alignment

At a planning level, consider the following factors when evaluating the location and alignment:

- Identify all stream crossings, springs, low areas, gullies, and impoundment areas created by the new roadway embankment and assess these locations for potential culvert locations.
- Locate and align culverts in a way that preserves the existing stream alignment and provides the stream with a direct entrance and exit. Avoid abrupt changes in direction at either end that may increase head loss and reduce capacity, making a larger structure necessary.
- Carefully consider bends relative to head losses and potential for debris accumulation and minimize abrupt changes in alignment.
- Where water must be turned into a culvert at an indirect angle, use headwalls, wingwalls, and aprons with configurations similar to those in Figure 11-8 as protection against scour and to provide an efficient inlet.
- Consider maintenance access to the culvert entrance and exit.

## 2.2 ENVIRONMENTAL PERMITTING

### 2.2.1 Wetlands

Environmental permitting is typically required for culvert and bridge projects due to their association with streams. For example, Section 404 of the Clean Water Act, administered by the United States Army Corps of Engineers (USACE), regulates construction activities in jurisdictional waters of the United States, including adjacent wetlands. Consult with local USACE representatives in the early stages of crossing design to assess the permitting requirements. State and local wetland regulations also may apply.

### 2.2.2 Floodplain Permitting

Culverts and bridges also often have regulatory floodplain implications. In cases where a No-rise Certification is not achievable, a Conditional Letter of Map Revision (CLOMR) and/or Letter of Map Revision (LOMR) is often required when a new culvert or bridge is installed and for major retrofit projects. For culvert and bridge projects in streams that may affect base flood elevations or the extents of regulatory floodplains, a CLOMR is advisable (and often required) to understand how the proposed project is likely to affect the floodplain and whether any insurable structures are adversely impacted. Projects that require a CLOMR through FEMA must provide an Endangered Species Act certification. Consult with the local jurisdiction early in the planning stages of the project to determine floodplain permitting requirements.

### 2.2.3 Construction Dewatering

Construction dewatering is often required for construction of culverts and bridges. Construction dewatering is regulated by the Colorado Public Health and Environment (CDPHE) through the General Permit for Discharges from Short-term (<2 year) Construction Dewatering Activities. If existing contamination is present in or around the area that will be dewatered, coverage under a remediation permit may be required.

## 2.2.4 Stormwater Permitting

For culvert and bridge projects that disturb more than 1 acre, coverage under the CDPHE's General Permit for Stormwater Discharges Associated with Construction Activities is required, and the permittee must prepare a Stormwater Management Plan (SWMP). Local governments and other Municipal Separate Storm Sewer System (MS4) permittees also have stormwater permit requirements, some of which apply to disturbances smaller than an acre.

## 2.2.5 Aquatic Organism Passage

The South Platte River watershed is home to diverse aquatic organisms, including trout in cold-water streams, smaller fish species throughout the eastern plains, and numerous other wildlife that move along riparian corridors. Road and pedestrian crossings that are located in or across these corridors can result in the permanent loss and fragmentation of important aquatic and riparian habitats. Where practical, crossings consolidate crossings to limit these impacts. When a stream crossing is required, consider the ecological impact and maintain or restore ecological continuity through riparian corridors to the extent practical.

In some settings, the ability of the culvert or bridge to accommodate aquatic organism passage is an important design consideration. Grade changes and control structures in the vicinity of hydraulic structures, high velocities through constrictions, and other factors may inhibit the ability of aquatic organisms to move upstream through crossings. When planning a stream crossing where aquatic organisms passage is an objective or requirement, consult with federal and state fish and wildlife agencies such as the U.S. Fish and Wildlife Services and Colorado Parks and Wildlife (CPW) early in the planning process.

Analyze stream crossing hydraulics from low flows to bankfull flows to verify that the design flow depth and velocity are conducive to the passage of the target species. Swimming speeds and required depths for various species have been estimated and included in multiple design guidance documents.

Existing crossings can be retrofitted to improve aquatic organism passage by increasing the tailwater depth and/or introducing roughness elements through the bottom of the crossing. In the case of retrofits, maintain or increase the culvert design capacity to avoid adverse hydraulic and geomorphic conditions that may affect aquatic organism passage.

## Aquatic Organism Passage Design Considerations

Bridges and other floodplain-spanning crossings have the least impact on aquatic habitats. As these large crossings are often not economical, culverts are typically installed at smaller stream crossings. There are many ways in which culverts can impede aquatic organism passage, including; vertical barriers at the culvert inlet or outlet due to scour or differences in grade, high velocities at the outlet and through the length of the culvert, shallow depths through the culvert and the lack of areas of refugia, abrupt changes in the hydraulics at the culvert inlet or outlet (flow acceleration and turbulence), as well as blockage due to debris build-up. Longer culverts generally present greater challenges to movement because the artificial environment is a longer. Avoid these impediments by considering fish passage and passage of other riparian species in design.

Maintaining geomorphic continuity through a crossing reduces the risk of habitat fragmentation.

Where bridge crossings are not practical, alternative structures such as three-sided or embedded culvert crossings may provide for aquatic organism passage if designed correctly. At a minimum, new crossings should span the bankfull channel width and maintain the creek slope, cross-section geometry, and bed material of the up- and downstream reaches. Material larger than the natural stream substrate may be required throughout the culvert to prevent the erosion of finer material during flood flows. Where the natural stream substrate cannot be continued through a crossing, sills, baffles, and other artificial roughness elements can reduce velocities, increase depths, and provide for important areas of refugia. Only consider these artificial roughness elements where the natural stream substrate cannot be continued through the crossing, or in instances of a retrofit to an existing crossing.

---

Refer to the following documents when designing stream crossings to limit the structure's impacts on aquatic organism passage.

- FHWA, 2010. Hydraulic Engineering Circular No. 26 (HEC-26): Culvert Design for Aquatic Organism Passage.
- FHWA, 2024. Aquatic Organism Passage at Highway Crossings: An Implementation Guide.
- U.S. Fish and Wildlife Service, 2024. Culvert Design Guidelines for Ecological Function.
- CDOT, 2019. Drainage Design Manual, Chapter 15: Water Surface Environment.
- ICON Engineering, 2025. Geomorphically Informed Stream Crossing Structures.
- Washington Department of Fish and Wildlife, 2003. Design of Road Culverts for Fish Passage.

---

Colorado Senate Bill 40 (33-5-101-107, CRS 1973 as amended) requires State agencies to obtain wildlife certification from CPW when the agency plans in-stream construction. While many projects do not require review from CPW, coordination with the agency may help determine target species and considerations to promote aquatic organism passage.

## 2.3 HYDROLOGY & HYDRAULICS

### 2.3.1 Design Flood Frequency and Discharge

For culverts that cross roadways, the design flood frequency is closely related to the pavement encroachment and road overtopping criteria presented in Tables 1-2, 1-3 and 1-4 in the *Policy* chapter. Most municipalities within MHFD have minimum design frequencies related to these tables that require culvert capacity for at least the 10-year event (and in some cases the 25-year event). However, for road and rail crossings of channels that drain a watershed of 130 acres or more, especially for arterial streets, freeways and critical crossings, a 100-year basis of design for conveyance (plus freeboard above the allowable headwater) is common.

Analyze scour and use a scour design frequency no more frequent than the design flood frequency used for hydraulic analysis. In some cases (e.g., bridge design), also analyze a less frequent flood (e.g., 200- or 500-year event) for scour. Please note that state and federal standards apply to relevant highway projects. For non-federal or state projects, select the design recurrence interval based on the criteria set forth in this manual in conjunction with local requirements and criteria for culvert sizing and road overtopping. Apply the more stringent of the applicable criteria if there are conflicting requirements.

The required hydraulic capacity (i.e., design flow) is based on the design flood frequency and the resulting design flow rate calculated for the watershed draining to the proposed culvert (see the *Runoff* chapter for information on hydrologic calculations). Design the structure to operate within acceptable limits of uncertainty of the design discharge by providing freeboard between the design headwater elevation and the point at which overtopping occurs for culverts or the low chords of bridges.

In some cases, culverts passing beneath rail may need to be designed to avoid surcharging beneath the rail (Union Pacific Engineering Department, 2019 and Union Pacific Railroad – BNSF Railway, 2016). When designing a crossing beneath a railroad, coordinate with representatives from the railroad early in planning to understand any special criteria that apply.

Culverts for lower-traffic roads may be designed to overtop in a 100-year event, while bridges are typically designed to pass the 100-year peak flow while allowing for freeboard. Consult local governing criteria for allowable overtopping frequencies.

### 2.3.2 Allowable Headwater Depth for Culverts

Culverts frequently constrict the natural stream flow, which causes a rise in the upstream water surface. The elevation of the upstream water surface is referred to as the headwater elevation. The depth of headwater is measured from the invert of the culvert inlet to the headwater elevation for a specified flow rate. In selecting the design headwater elevation, consider the following:

1. The headwater depth/culvert diameter ratio ( $HW/D$ ) should not exceed the maximum values listed in Table 11-1 for the 100-year peak flow unless justification is provided for a greater ratio and sufficient measures are taken to protect the culvert inlet (for example, a concrete headwall). Piping failure can be of concern for deep headwater depths, especially if there are animal burrows in the embankment.
2. Assess the impacts caused by exceeding the design headwater depth, including:
  - a. Hazards to human life and safety.
  - b. Potential damages to the culvert, embankment stability, and roadway.
  - c. Traffic interruption in the event of roadway overtopping.
  - d. Anticipated upstream and downstream flood risks, for a range of return frequencies.

- Evaluate the topography surrounding the culvert entrance relative to design headwater elevation. Design the culvert so that the headwater elevation will not result in runoff spilling over topographic drainage divides and creating unintended split flow conditions or overflow paths.

**Table 11-1. Maximum headwater depth to culvert diameter (or height) ratios (HW/D) (CDOT, 2019)**

Range of Diameter or Height of Culvert	Maximum HW/D
< 36 inches	2.0
36 – 60 inches	1.7
> 60 inches and < 84 inches	1.5
84 inches to < 120 inches	1.2
120 inches or larger	1.0

### 2.3.3 Tailwater Depth for Culverts

Tailwater is the depth of flow in the downstream channel, measured from the invert of the culvert outlet to the water surface level (typically assuming normal flow in the channel downstream of the culvert). Knowledge of tailwater depth is critical for culvert design because a submerged outlet may cause the culvert to flow full rather than partially full. In general, tailwater depths should be computed for the same design storm frequencies used for culvert design.

In some cases where there is a confluence with a waterbody draining a much larger watershed that controls tailwater conditions, the joint probability of the culvert and the waterbody draining a much larger watershed experiencing concurrent peak flooding may be a much lower probability than the design event used for the culvert. In these cases, design engineers may submit hydrologic analysis evaluating the joint probability of flooding to justify a tailwater depth that is compatible with the design storm frequency used for sizing the culvert. Hydrologic Engineering Circular No. 19 (HEC-19), Highway Hydrology: Evolving Methods, Tools, and Data provides guidance on evaluating coincident frequency of flooding at stream confluences (FHWA, 2023).

Conduct a field inspection of the downstream channel to determine whether there are obstructions that may influence the tailwater depth and to determine an appropriate roughness value to use for tailwater computations. Tailwater depth may be controlled by several factors, including the stage in a contributing stream, headwater/backwater from structures downstream of the culvert, reservoir water surface elevations, or other downstream features.

Calculate tailwater depth using a computer program, such as HEC-RAS or HY-8, that can represent tailwater effects from user-defined downstream channel geometry. In some cases normal depth calculations for the downstream channel for the design event may be sufficient to establish a design tailwater depth (this is one of the ways that HY-8 can develop a tailwater rating curve).

### 2.3.4 Allowable Outlet Velocity for Culverts

The outlet velocity of a culvert, measured at the downstream end of the culvert, is usually higher than the maximum velocity that a natural channel can withstand without experiencing significant erosion of the bed and/or banks. Most culverts require outlet protection (typically riprap or a stilling basin), and this is often overlooked during design. See the *Hydraulic Structures* chapter in Volume 2 of the USDCM for criteria and guidance for outlet protection for culverts.

Permissible velocities at the outlet will depend upon streambed type, and the type of energy dissipation (outlet protection) that is provided. As a general rule, the velocity at the downstream edge of a project right-of-way or downstream area of influence should not be greater than the pre-construction velocity.

If the outlet velocity of a culvert is too high, the velocity may be reduced by decreasing the slope or increasing the barrel roughness, since slope and roughness are the principal factors affecting the outlet velocity. Variations in shape and size of a culvert seldom have a significant effect on the outlet velocity. If changing the barrel slope or roughness does not provide a satisfactory reduction in outlet velocity, it may be necessary to incorporate some type of outlet protection or energy dissipation device.

### 2.3.5 Culvert Design Details

Culvert design should always include preparation of hydraulic profiles through the culvert for the range of design events analyzed and assessment of potential flood or erosional hazards due to overtopping. Plans should also show the following:

- Culvert size and geometry.
- Culvert design flows and recurrence intervals.
- Culvert material.
- Alignment, grade, and length of culvert.
- Abrasion and corrosion protective measures, if required.
- Culvert inlet design, including headwall and wingwalls, as applicable.
- Culvert end treatment and erosion protection.
- Culvert overflow frequency and overflow path.
- Amount and type of cover material required.
- Erosion control for stabilization of disturbed slopes.



**Photograph 11-3.** A three-cell box culvert on Wonderland Creek.

## Hydraulic and Geomorphic Design Considerations

Hydraulic and geomorphic design considerations include the following:

- What are the impacts of various culvert sizes, dimensions, and materials on upstream and downstream flood risks, including the implications of embankment overtopping?
- What type of sediment load and bed load can be anticipated for the culvert? For streams with a heavy bed load, abrasion and debris blockage can be of concern. For culverts with milder slopes or abrupt changes to a flatter grade within the culvert, sediment deposition can be problematic and lead to increased maintenance frequency. If the culvert is in an area where there is potential for significant debris (mountainous terrain, pine beetle kill areas, recently burned areas, etc.), apply appropriate conservative assumptions for blockage and overflow paths.
- How does the culvert affect the hydraulics and geomorphology of the stream? Maintain hydraulic and sediment transport continuity through a crossing by sizing structures to span the bankfull channel when feasible, and consider configurations using multiple culverts to maintain hydraulic conveyance under flood conditions and minimize backwater effects. These practices help to reduce sediment deposition upstream of (and in) the culvert and avoid constriction of flows that can lead to costly downstream energy dissipation and erosion control measures.
- Do culvert hydraulics create conditions favorable for sediment deposition? Sediment deposits in culverts may occur due to the following conditions:
  - At low and moderate flow rates, the culvert cross section may be larger than that of the stream, so the flow depth and sediment transport capacity is reduced.
  - Point bars form on the inside of stream bends. Culvert inlets placed at bends in the stream may be subject to deposition in the same manner. This effect is most pronounced in multiple-barrel culverts with the barrel on the inside of the curve often becoming almost totally plugged with sediment. Consider the effect of the culvert shape, size, and skew of the alignment to minimize potential for sediment deposits and plugging and improve floodplain connectivity.

Instream structures upstream of the inlet or depressing a low flow channel in the culvert can help to concentrate flows at the entrance and through the culvert. Concentrating flows through culverts increases velocity and may reduce sediment and debris accumulation near a culvert entrance; however, this also may require downstream energy dissipation and channel stabilization measures for natural-bottom culverts.

## 3.0 CULVERT HYDRAULICS

### 3.1 KEY HYDRAULIC PRINCIPLES

This chapter is based on the assumption that the reader has a basic working knowledge of hydraulics and is familiar with the Manning's Equation (Equation 11-1), the Continuity Equation (Equation 11-2), and the energy equation for steady incompressible flow (Equations 11-3 and 11-4):

$$Q = \frac{1.49}{n} AR^{2/3} S^{1/2}$$

Equation 11-1

**Where:**

$Q$  = flow rate or discharge (cubic feet per second)  
 $n$  = Manning's roughness coefficient (see Table 11-2)  
 $A$  = cross-sectional area of flow (ft<sup>2</sup>)  
 $R$  = hydraulic radius (ft)  
 $S$  = longitudinal slope (ft/ft)

$$Q = v_1 A_1 = v_2 A_2$$

Equation 11-2

**Where:**

$Q$  = flow rate or discharge (cfs)  
 $v$  = velocity (ft/s)  
 $A$  = cross-sectional area of flow (ft<sup>2</sup>)

Subscripts refer to two different locations within a culvert or channel between which flow is constant.

$$E_1 + losses = E_2$$

Equation 11-3

**Where:**

$E$  = energy of flow, expressed as head (ft)  
 $v$  = velocity (ft/s) - Note:  $v^2/(2g)$  = velocity head (ft)  
 $g$  = gravitational acceleration (32.2 ft/s<sup>2</sup>)  
 $p$  = pressure (lb/ft<sup>2</sup>)  
 $\gamma$  = specific weight of water (62.4 lb/ft - Note:  $p/\gamma$  = pressure head or depth of flow (ft))  
 $z$  = height above datum (ft)  
 $Losses$  = hydraulic losses (ft) due to pipe or channel friction, bends, junctions, contractions/expansions, etc. between two points being evaluated along a flow line

$$\frac{v_1^2}{2g} + \frac{p_1}{\gamma} + z_1 + Losses = \frac{v_2^2}{2g} + \frac{p_2}{\gamma} + z_2$$

Equation 11-4

Subscripts refer to two different locations within a culvert or channel between which flow is constant.

**Table 11-2.** Manning’s roughness coefficients for common culvert materials

	Reinforced Concrete Pipe (RCP)	Aluminized Steel Pipe (ASP)	Polymer Coated Steel Pipe	Corrugated Metal Pipe (CMP)*	Polyvinyl Chloride Pipe (PVC)	High Density Polyethylene (HDPE) Pipe
Manning’s Roughness Coefficient	0.013	0.013	0.013	0.024	0.011	0.012

\* Manning’s roughness coefficient varies based on diameter and height of corrugation for some types of corrugated aluminum or steel pipes. See American Iron and Steel Institute, 1980 or consult with manufacturer to determine appropriate roughness value. For values that vary from this table, provide documentation of basis for Manning’s roughness coefficient in design submittals.

### 3.1.1 Energy and Hydraulic Grade Lines

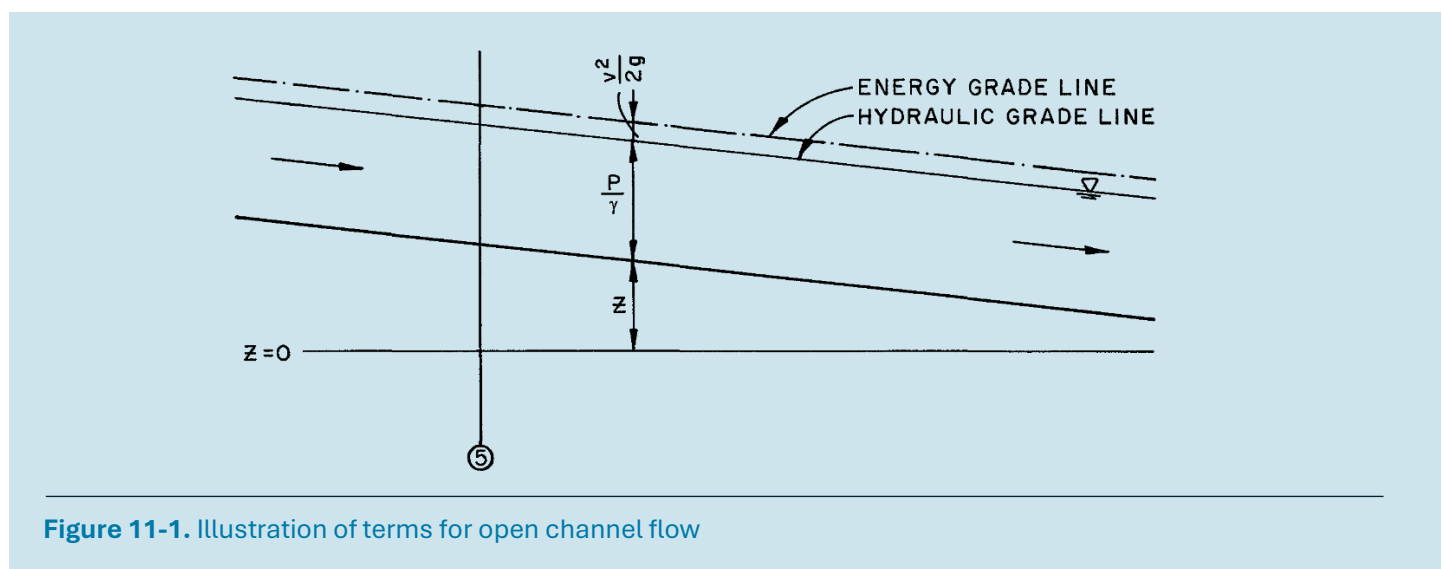
The concepts of energy grade line (EGL) and hydraulic grade line (HGL), and related terms, are illustrated for open channel flow and closed conduit flow in Figure 11-1 and Figure 11-2, respectively.

#### Open Channel Flow

The EGL, also known as the line of total head, is the sum of velocity head ( $v^2/2g$ ), the depth of flow or pressure head ( $p/g$ ), and elevation above an arbitrary datum represented by the distance ( $z$ ). The energy grade line slopes downward in the direction of flow by an amount equal to the energy gradient ( $H_L/L$ ), where  $H_L$  equals the total energy loss over the distance  $L$ .

The HGL, also known as the line of piezometric head, is the sum of the depth of flow or pressure head ( $p/g$ ), and the elevation ( $z$ ). The HGL does not include the velocity head.

For open channel flow, the term  $p/g$  is equivalent to the depth of flow and the hydraulic grade line is the same as the water surface shown on Figure 11-1.



**Figure 11-1.** Illustration of terms for open channel flow

## Closed Conduit Flow

While it is preferable to design culverts for open channel flow conditions (i.e., non-pressurized flow), when a culvert is designed with a headwater depth exceeding the top of the culvert (not uncommon), pressurized flow may develop under some tailwater conditions and/or during events that exceed the design capacity of the culvert. For pressurized flow in closed conduits,  $p/\gamma$  is the pressure head and the hydraulic grade line is above the top of the conduit, provided that the pressure relative to atmospheric pressure is positive (see Figure 11-2).

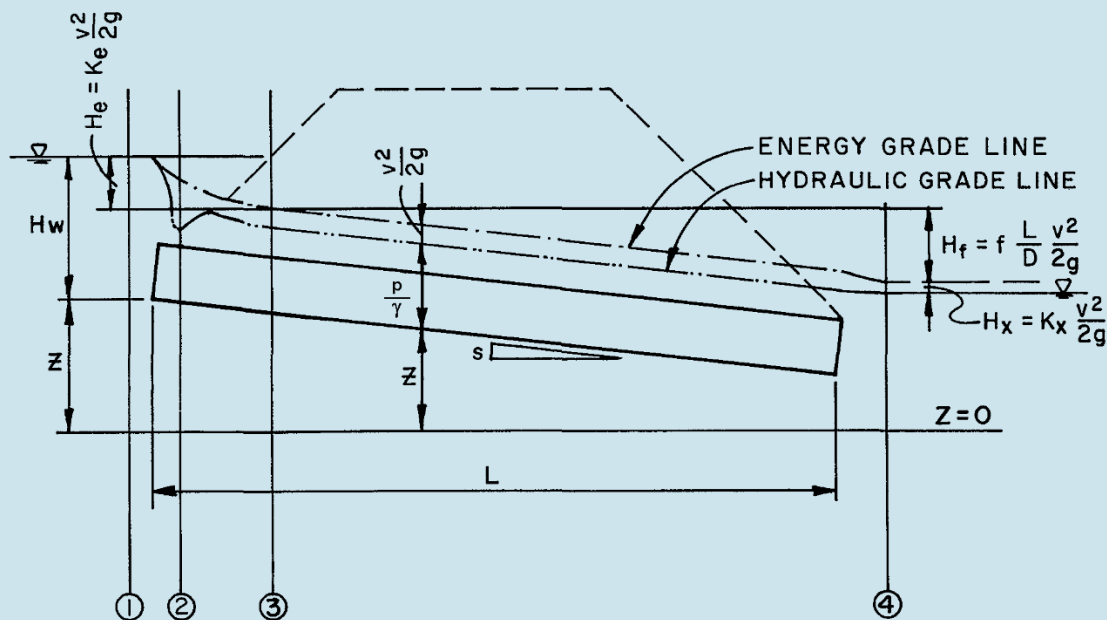


Figure 11-2. Illustration of terms for closed conduit flow

For the headwater at entrance of a culvert (Point 1 on Figure 11-2) the velocity is commonly considered minimal, and the energy grade line and hydraulic grade line are nearly the same. As water enters the culvert at the inlet, the flow is contracted by the inlet geometry causing a loss of energy (Point 2). As a turbulent velocity distribution is reestablished downstream of the entrance (Point 3), a loss of energy occurs due to frictional resistance from the culvert. In short culverts, the entrance losses are likely to be high relative to the friction loss in the barrel of the culvert. At the culvert exit (Point 4), there are additional losses due to turbulence as the flow expands and is retarded by the tailwater in the downstream channel.

### 3.1.2 Inlet and Outlet Control

There are two basic types of flow conditions in culverts: (1) *inlet control* and (2) *outlet control*. For each type of control, the hydraulic capacity of the culvert is determined based on different combinations of factors. Over a range of event frequencies (and even within an event as the hydrograph rises and falls), most culverts experience both inlet and outlet control conditions at times. The determination of actual flow conditions can be difficult; therefore, the designer must check for both types of control and design for the most adverse condition (i.e. greatest headwater depth between the two methods).

## Inlet Control

Inlet control occurs when the energy losses at the culvert entrance dictate how much flow a culvert can convey. A culvert operates under inlet control when the flow capacity of the culvert is controlled by these factors:

- Depth of headwater,
- Inlet edge configuration, and
- Cross-sectional area and geometry of culvert opening.

With inlet control, the culvert barrel usually flows only partially full. Inlet control for culverts can occur under unsubmerged or submerged conditions.

**Unsubmerged Inlet:** The headwater depth is not sufficient to submerge the top of the culvert and the culvert invert slope is supercritical, as shown in Figure 11-3.

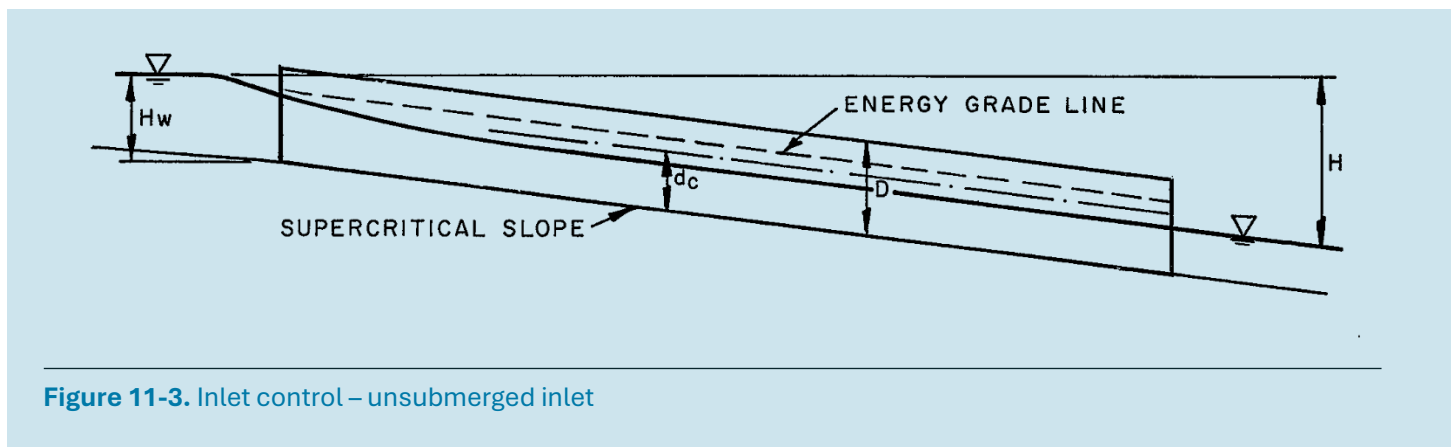


Figure 11-3. Inlet control – unsubmerged inlet

**Submerged Inlet:** The headwater submerges the top of the culvert, and the pipe does not flow full (Figure 11-4). This is the most common condition of inlet control.

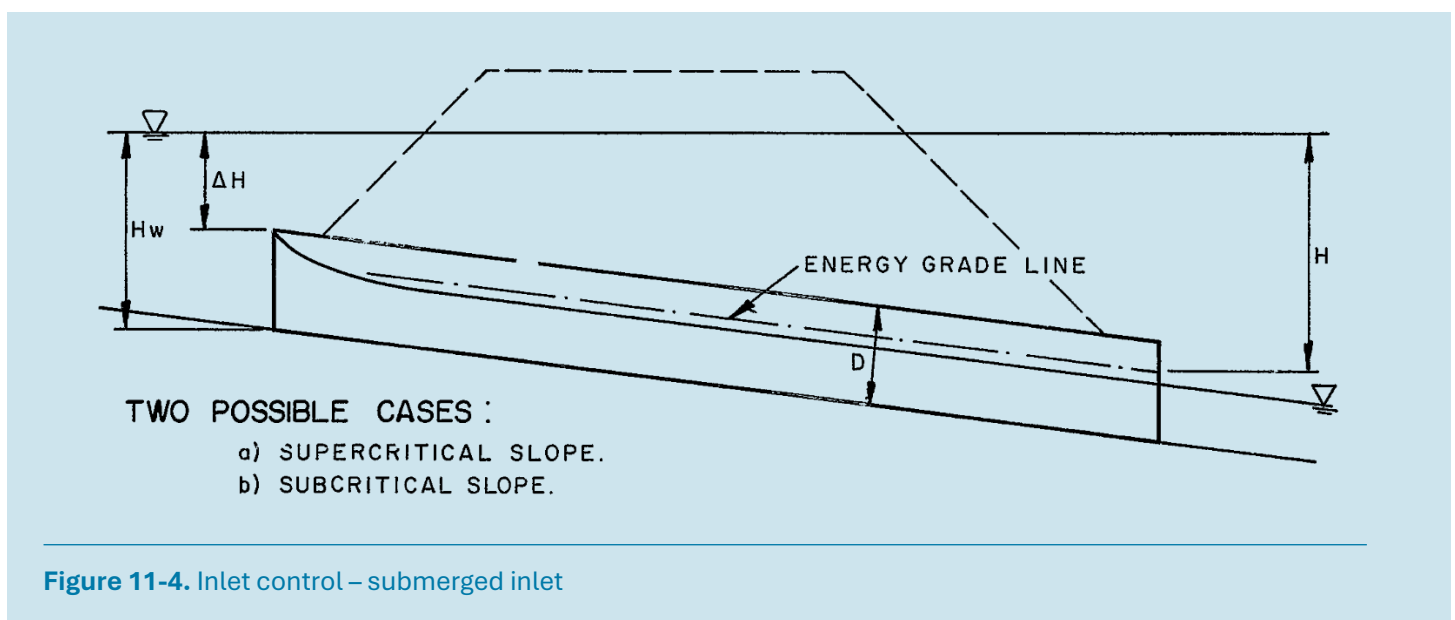


Figure 11-4. Inlet control – submerged inlet

A culvert flowing under inlet control is sometimes referred to as a “hydraulically short” culvert.

## Outlet Control

Outlet control refers to all head loss mechanisms other than those that occur at the culvert inlet. These outlet control mechanisms include head loss attributed to pipe friction, bends, expansion at the culvert outlet, and tailwater. Outlet control is the common term used when these losses dictate the capacity of a culvert, (FHWA, 2005). Conditions that may cause outlet control include high headwater, relatively flat culvert slope, or sufficiently long culvert length. With outlet control, culvert hydraulic performance is determined by the following factors:

- Depth of headwater,
- Inlet edge configuration,
- Cross-sectional area,
- Bends (if applicable),
- Culvert shape,
- Barrel slope,
- Barrel length,
- Barrel roughness, and
- Depth of tailwater.

Outlet control for culverts can occur under partially full or full conduit conditions.

**Partially Full Conduit:** The headwater depth is insufficient to submerge the top of the culvert, and the culvert slope is subcritical, resulting in the culvert flowing partially full (Figure 11-5). This is the least common condition of outlet control.

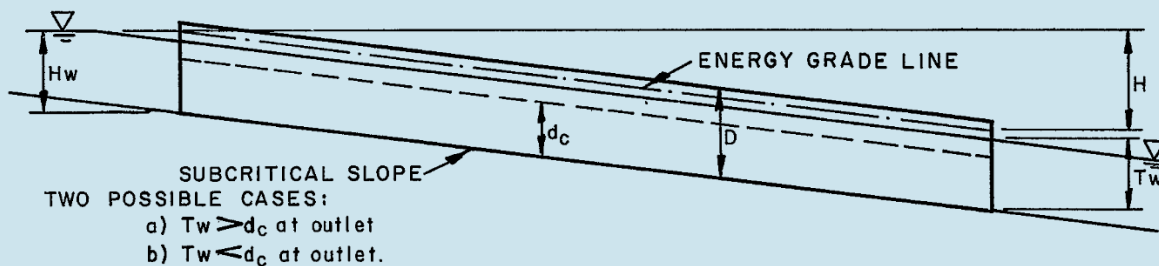


Figure 11-5. Outlet control – partially full conduit

**Full Conduit:** The culvert flows full along its length (Figure 11-6). This is the most common condition of outlet control.

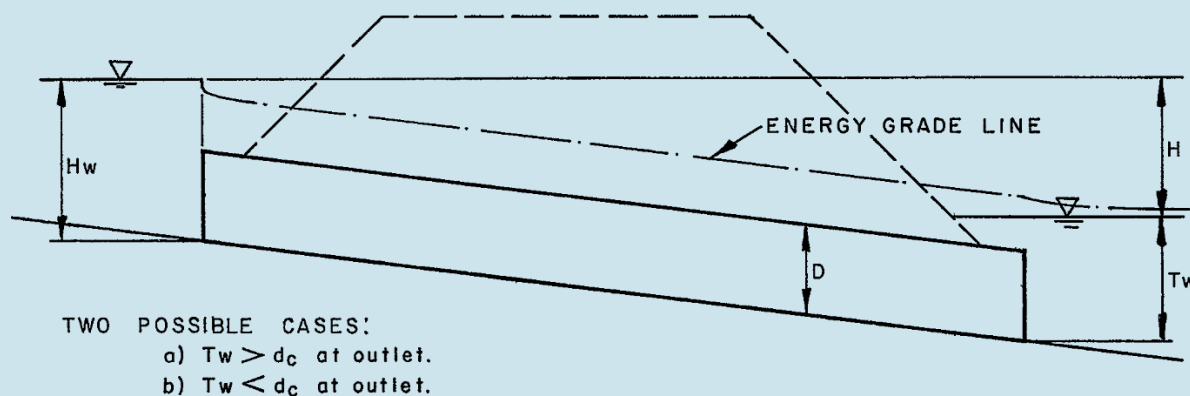


Figure 11-6. Outlet control – full conduit

A culvert flowing under outlet control is sometimes referred to as a “hydraulically long” culvert. With outlet control, factors that may affect performance for a given culvert size and headwater depth are barrel length, barrel roughness, and tailwater depth.

## 3.2 ENERGY LOSSES

Evaluate the following energy losses to determine the carrying capacity of a culvert:

- Inlet or entrance losses (Section 3.2.1)
- Friction losses through the culvert (Section 3.2.2)
- Bend losses (if applicable) (Section 4 of the Streets, Inlets, and Storm Drains chapter)
- Outlet (or exit) losses (Section 3.2.3)

It is noteworthy that the entrance losses in a culvert can be as important as the friction losses, particularly in short culverts.

### 3.2.1 Inlet Losses

For inlet losses, the governing equations are:

$$Q = CA\sqrt{2gH}$$

Equation 11-5

**Where:**

- $Q$  = flow rate or discharge (cfs)
- $C$  = contraction coefficient (dimensionless)
- $A$  = cross-sectional area (ft<sup>2</sup>)
- $g$  = acceleration due to gravity (32.2 ft/s<sup>2</sup>)
- $H$  = total head (ft)
- $H_e$  = head loss at entrance (ft)
- $K_e$  = entrance loss coefficient (dimensionless, see Section 5.0)
- $v$  = average velocity (ft/s)

$$H_e = K_e \frac{v^2}{2g}$$

Equation 11-6

and

## 3.2.2 Friction Losses

### Capacity based on headwater relevant to culvert rise

FHWA has determined that the orifice equation is not valid representation of actual capacity until the headwater (H) is at least 3 times the height (rise) of the culvert. For H less than 0.5 x rise, apply open channel minimum energy equations, and for 0.5 x rise < H < 3 x rise, use empirical best-fit equations. This methodology is programmed into HY-8.

### Pipes Flowing Partially Full

Friction head loss for pipes flowing partially full can be determined from the Manning's equation reformulated to calculate head loss:

$$H_f = \left( \frac{29n^2L}{R^{4/3}} \right) \left( \frac{v^2}{2g} \right)$$

Equation 11-7

**Where:**

- $H_f$  = frictional head loss in culvert barrel (ft)
- $n$  = Manning roughness coefficient (dimensionless)
- $L$  = culvert length (ft)
- $R$  = hydraulic radius (ft, area/wetted perimeter)
- $A$  = cross-sectional area of culvert barrel (ft<sup>2</sup>)
- $v$  = average velocity (ft)
- $g$  = acceleration due to gravity (32.2 ft/s<sup>2</sup>)

### Pipes Flowing Full

Friction head loss for turbulent flow in pipes flowing full can be determined from the Darcy-Weisbach equation:

$$H_f = f \left( \frac{L}{D} \right) \left( \frac{v^2}{2g} \right)$$

Equation 11-8

**Where:**

- $H_f$  = frictional head loss (ft)
- $f$  = friction factor (dimensionless)
- $L$  = culvert length (ft)
- $D$  = pipe diameter (ft)
- $v$  = average velocity (ft)
- $g$  = acceleration due to gravity (32.2 ft/s<sup>2</sup>)

### 3.2.3 Outlet Losses

For outlet (or exit) losses, the governing equations are related to the difference in velocity head between the flow in the culvert and the flow in the channel downstream of the culvert. The downstream channel velocity is usually neglected, resulting in the outlet losses being equal to the velocity head of full flow in the culvert barrel, given by the following:

$$H_o = \frac{v^2}{2g}$$

Equation 11-9

**Where:**

$H_o$  = outlet head loss (ft)

$V$  = average velocity in culvert barrel (ft)

$g$  = acceleration due to gravity (32.2 ft/s<sup>2</sup>)

### 3.2.4 Total Losses

The following equation for head loss, the difference in the headwater and tailwater elevations, combines the relationships for entrance loss, friction loss, and outlet (or exit) loss:

$$H = \left[ 1 + K_e + \frac{29n^2L}{R^{4/3}} \right] \frac{v^2}{2g}$$

Equation 11-10

**Where:**

$H$  = difference in the headwater and tailwater elevations (ft)

$K_e$  = entrance loss coefficient (dimensionless)

$n$  = Manning's roughness coefficient (dimensionless)

$L$  = culvert length (ft)

$R$  = hydraulic radius (area/wetted perimeter)

$v$  = average velocity (ft)

$g$  = acceleration due to gravity (32.2 ft/s<sup>2</sup>)

## 4.0 CULVERT SIZING AND DESIGN

The hydraulic design of culverts is typically accomplished using a computer program such as HY-8 or HEC-RAS, depending on the nature of crossing and upstream and downstream conditions. In addition to these public domain computer applications, numerous proprietary computer applications are also available for the hydraulic design of culverts. Proprietary software is discouraged because of the costs to local governments and/or MHFD to obtain licenses. MHFD and local governments may consider whether the specific proprietary software may be used on a case-by-case basis.

Capacity charts and nomographs were frequently used before the widespread use of computers; however, they are older methods that are now less commonly used. Capacity charts are no longer incorporated into FHWA's culvert design publications. FHWA's HDS 5 (2012), includes nomographs in Appendix C for a variety of culvert configurations, along with a detailed procedure for using nomographs for sizing culverts. These nomographs are graphical representations of the equations that are programmed into HY-8 and should produce comparable results to HY-8 when properly applied.

### 4.1 HY-8

HY-8 is a software program developed by FHWA as a culvert design tool. Input data include the range of design flows, tailwater channel characteristics, a roadway cross section, and an embankment template. HY-8 includes commercially available culvert sizes and materials and produces a performance curve and report for the culvert crossing. HY-8 is applicable to culvert crossings without upstream or downstream structures affecting hydraulics. HY-8 may be used for evaluation of tapered inlets, irregular shaped culverts, embedded culverts, and broken-back culverts. HY-8 is a useful tool when energy dissipator design is expected (FHWA, 2012).

### 4.2 HEC-RAS

HEC-RAS is a hydraulic analysis tool that can be applied to a stream reach with culverts and/or bridges to evaluate water surface profiles for user-specified peak flow rates. HEC-RAS is typically applied for steady flow analysis to design bridges and culverts; although, unsteady versions of HEC-RAS may be applicable in some cases where sediment transport is of interest. HEC-RAS should be used if any of the following apply:

- Crossing has a combination of bridges and culverts,
- Stream has upstream or downstream structures that affect hydraulics at crossing,
- A water surface profile is needed for the stream reach (for example, to evaluate backwater effects upstream), or
- Stream reach is part of a Federal Emergency Management Agency (FEMA) regulatory floodplain.

HEC-RAS has the same commercially available culvert alternative material and size ranges as HY-8. HEC-RAS also uses National Bureau of Standards equations from Appendix A of HDS 5 for inlet control computations (FHWA, 2012). HEC-RAS

#### Computer Applications for Hydraulic Design of Culverts

The following public domain computer applications are available for free download at the addresses shown and are acceptable for use in conjunction with this chapter:

- Federal Highway Administration (FHWA) HY-8 Culvert Analysis Program (FHWA, 2024).  
<http://www.fhwa.dot.gov/engineering/hydraulics/software/hy8/>
- U.S. Army Corps of Engineers Hydrologic Engineering Center - River Analysis System (HEC-RAS):  
<http://www.hec.usace.army.mil/software/hecras/>

and HY-8 provide similar solutions for submerged inlets and United States Geological Survey (USGS) flow types 4, 5, 6 and 7. For unsubmerged inlets and USGS flow types 1, 2, and 3, HEC-RAS carries the water surface profile through the structure and maintains the approach velocity.

## 4.3 DESIGN CONSIDERATIONS

The design of a culvert is more complex than simply sizing culvert dimensions, since other considerations arise with site-specific factors. The procedures for design in this manual only represent guidelines, since actual design considerations encountered are too varied and too numerous to be generalized. The process presented in this chapter is intended to help planners and designers think through a range of potential issues that may need to be addressed in the design process. Evaluate several combinations of entrance types, invert elevations, and pipe diameters to determine the most economic design that will meet the conditions imposed by topography and engineering constraints. The following sections discuss specific design considerations.

### 4.3.1 Culvert Profile

After determining the allowable headwater elevation, the tailwater elevation, and the approximate culvert length, assign culvert inlet elevations. Significant scour is less likely when the culvert has the same slope as the channel. To reduce the chance of failure due to scour, use invert elevations corresponding to the natural grade as a first trial. Investigate the flow conditions downstream from the culvert to determine if scour is likely and evaluate the area upstream of the planned culvert for the potential of debris or adverse consequences from increased sedimentation or backwater effects.

Design the culvert entrance and exit elevations and orientation to minimize changes to upstream and downstream flow characteristics to maintain sediment transport continuity through the embankment. Refer to MHFD's *Geomorphically Informed Stream Crossing Structures* guidance document (ICON Engineering, 2025) for additional information on maintaining geomorphic continuity at stream crossings.

Creating a drop structure at the outlet of the culvert and with a depressed basin beneath the drop, as shown in drop structure details in the *Hydraulic Structures* chapter, establishes a sediment and debris collection area that minimizes the risk of blockage in front of the culvert outlet.

### 4.3.2 Minimum Culvert Diameter

Since small diameter culverts are often plugged by sediment and debris and difficult to maintain, culverts in the public right-of-way should have diameters of no less than 15 inches. Larger culverts will be easier to maintain and more effective for drainage over the long term than smaller culverts. Private driveway culverts may have diameters as small as 12 inches.

### 4.3.3 Limited Headwater

If there is limited headwater to drive the design flow through the culvert, consider options such as oversizing the culvert barrel, lowering the inlet invert, using an alternate cross section (arch or elliptical), or a combination of the preceding to increase the discharge rate.

If the inlet invert is lowered, consider the potential for upstream headcutting and scour from the acceleration of flow into the culvert. Evaluate the use of a drop structure, riprap or other protective measures, along with headwalls, apron, and toe walls, to stabilize the area around the culvert entrance and prevent upstream propagation of headcutting.

### 4.3.4 Culvert Outlet

Check the outlet velocity for potential downstream scour during the major storm. If scour is indicated, which is frequently the case, refer to the *Outlet Protection* section of this chapter (Section 6.0). Inadequate culvert outlet protection is a common problem. Erosion undermines the culvert outlet and degrades the downstream channel unless adequate culvert outlet protection is provided.

### 4.3.5 Minimum Velocity

To minimize sediment deposition in the culvert, maintain a minimum velocity of 3 feet per second during the average annual flow event. If the minimum velocity is not achieved based on the design slope and average annual peak flow, consider decreasing the culvert diameter, steepening the slope, using a smoother culvert, or a combination of these to increase velocity.

### 4.3.6 Culvert Shape

Carefully select the shape of culvert based on the characteristics and needs of the stream, providing functionality beyond simply conveyance when feasible. For example, a circular culvert may effectively handle the design peak discharge but could limit the movement of aquatic organisms and sediment or debris, while potentially encroaching the floodplain. In contrast, a sunken-bottom four-sided culvert or three-sided culvert can maintain the natural streambed, improve sediment and debris conveyance, and support fish passage. Arch culverts are also typically compatible with aquatic organism passage and can be used to span the bankfull channel for smaller streams. Box culverts are well suited for passing high flow rates and velocities, while elliptical culverts are often used in situations where vertical cover is a constraint. Where possible, size the width of the culvert to span the bankfull width of the channel to minimize disruptions to sediment transport, decreasing the sediment fall out at the inlet and decreasing the maintenance burden (ICON Engineering, 2025).

## 5.0 CULVERT INLETS

A culvert's capacity is ultimately determined by the amount of water that can enter the inlet. While engineers often focus on factors such as slope, cross section, hydraulic roughness, and other parameters, it's important to remember the inlet's role in the overall design.

The longer a culvert is, the more important it is to design a hydraulically efficient entrance. A large culvert unable to flow at the design capacity represents wasted investment. Typically, air vents are necessary immediately downstream of the entrance of a long culvert to allow entrained air to escape and to act as breathers should sub-atmospheric pressures develop in the pipe due to high velocities.

Where constraints exist such as limited headwater depth, erosion problems, or where sedimentation is likely, a more efficient inlet may be required to obtain the necessary discharge for the culvert. Conversely, if detention or other temporary water storage upstream from the culvert is desirable, an inlet with more limited capacity may be an economical choice (in such a case, the embankment should effectively be designed as a dam). The design of a culvert, including both the inlet and the outlet, requires a balance between cost, hydraulic efficiency, purpose, and topography at the proposed culvert site.

The entrance coefficient,  $K_e$ , a variable in Equation 11-6 and Equation 11-10, is a measure of the hydraulic efficiency at the inlet, with lower values indicating greater efficiency (lower head losses). Table 11-3 provides recommended entrance loss coefficients. Different types of inlets and their suited uses are defined in Section 5.1.

**Table 11-3. Entrance loss coefficients (FHWA, 2012)**

Type of Structure and Entrance Design	Entrance Loss Coefficient, $K_e$
<b>Concrete Pipe</b>	
Projecting from fill, socket end (groove-end)	0.2
Projecting from fill, sq. cut end	0.5
Headwall or headwall and wingwalls	
Socket end of pipe (groove-end)	0.2
Square-edge	0.5
Rounded (radius = D/12)	0.2
Mitered to conform to fill slope	0.7
*End-Section conforming to fill slope	0.5
Beveled edges, 33.7° or 45° bevels	0.2
Side- or slope-tapered inlet	0.2
<b>Corrugated Metal Pipe or Arch Pipe</b>	
Projecting from fill (no headwall)	0.9
Headwall or headwall and wingwalls square-edge	0.5
Mitered to conform to fill slope, paved or unpaved slope	0.7
*End-Section conforming to fill slope	0.5
Beveled edges, 33.7° or 45° bevels	0.2
Side- or slope-tapered inlet	0.2
<b>Reinforced Concrete Box</b>	
Headwall parallel to embankment (no wingwalls)	
Square-edged on 3 edges	0.5
Rounded on 3 edges to radius of D/12 or B/12 or beveled edges on 3 sides	0.2
Wingwalls at 30° to 75° to barrel	
Square-edged at crown	0.4
Crown edge rounded to radius of D/12 or beveled top edge	0.2
Wingwalls at 10° to 25° to barrel	
Square-edged at crown	0.5
Wingwalls parallel (extension of sides)	
Square-edged at crown	0.7
Side- or slope-tapered inlet	0.2

\* Note: "End Sections conforming to fill slope" made of either metal or concrete, are the sections commonly available from manufacturers. From limited hydraulic tests they are equivalent in operation to a headwall in both inlet and outlet control. Some end sections, incorporating a closed taper in their design have a superior hydraulic performance. These latter sections can be designed using the information given for the beveled inlet.

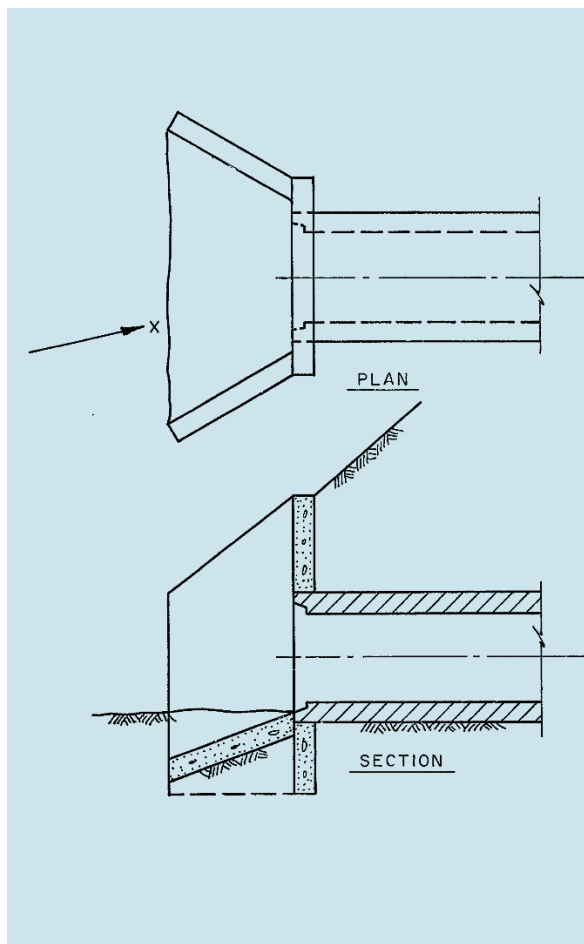
# 5.1 TYPES OF INLETS AND APPURTENANT STRUCTURES

## 5.1.1 Headwalls

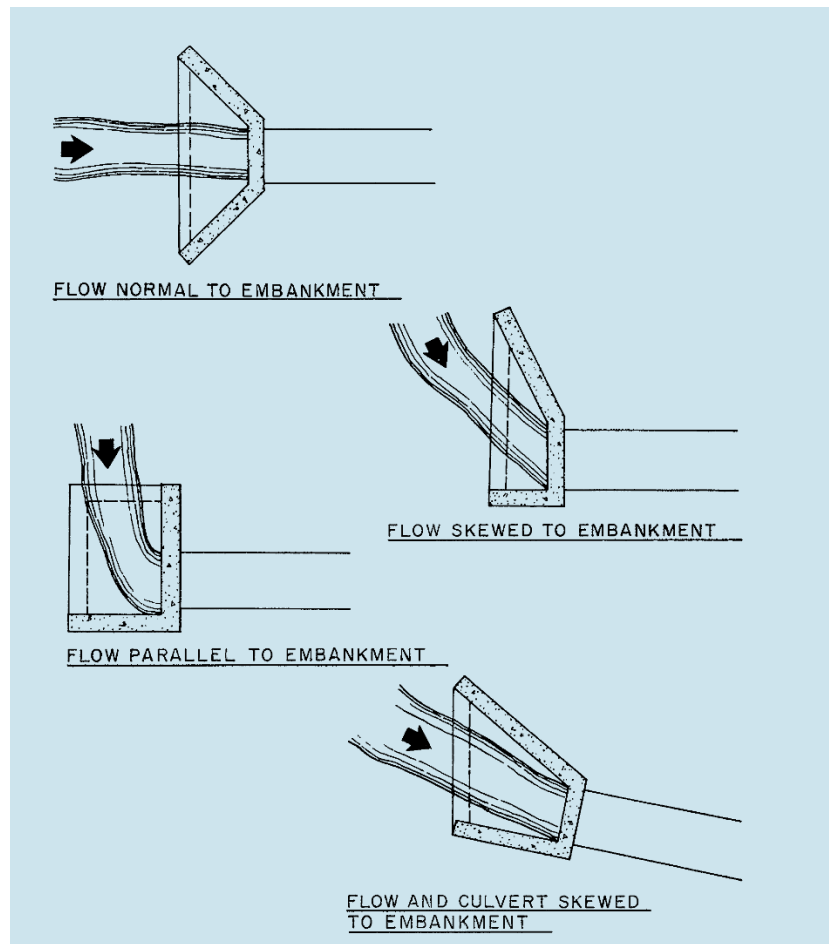
Headwalls are used for a variety of reasons, including increasing the inlet efficiency, providing embankment stability, and protecting the embankment from erosion. The relative efficiency of the inlet varies with the pipe material used as well as with the orientation of headwalls and wingwalls relative to the direction of flow entering the culvert. Figure 11-7 illustrates an inlet configuration with a headwall and wingwalls.

## 5.1.2 Wingwalls

Wingwalls are used where the side slopes of the channel adjacent to the entrance are unstable and/or where the culvert is skewed to the normal channel flow. Wingwalls are often needed to transition from the channel bottom to the embankment slope without creating grades that are too steep. Wingwalls do not provide a large improvement in hydraulic efficiency, regardless of the pipe material used, and therefore, should be justified for reasons other than an increase in hydraulic efficiency. Figure 11-8 illustrates several cases where wingwalls are used. For parallel wingwalls, the minimum distance between wingwalls should be at least 1.25 times the diameter of the culvert.



**Figure 11-7.** Inlet with headwall and wingwalls



**Figure 11-8.** Typical headwall-wingwall configurations

### 5.1.3 Aprons

If high headwater depths are anticipated, or if the approach velocity of the channel will cause scour, provide a short channel apron at the toe of the headwall. Extend this apron at least one pipe diameter upstream from the entrance. The top of the apron should not protrude above the normal streambed elevation.

Design culverts with wingwalls with a concrete apron extending between the walls. Reinforce aprons to control cracking. As illustrated in Figure 11-8, the actual configuration of the wingwalls varies according to the direction of flow and will also vary according to the topographical characteristics of the site. Incorporate a toe wall/cutoff into the apron design to guard against scour.

### 5.1.4 Special Inlets

A large variety of inlets exist in addition to those described previously. Among these are special end-sections (i.e., flared end sections), which are frequently used at both ends of culverts. This section discusses special inlets for concrete and corrugated metal pipes, two of the most common pipe materials, although similar improved inlets are manufactured for other pipe types. Because of differing requirements due to pipe materials, special end-sections for corrugated metal pipe and concrete pipe are discussed separately. Mitered inlets and inlets for long conduits also are discussed in this section.

#### Corrugated Metal Pipe

Special end-sections for corrugated metal pipe add little to the overall cost of the culvert and have the advantages of reducing the potential for damage and maintenance requirements compared to a projecting entrance and increased hydraulic efficiency.

#### Concrete Pipe

As with corrugated metal pipe, concrete flared end-sections (FES) protect the end of the pipe during maintenance activities and may aid in increasing the embankment stability or in retarding erosion at the inlet. When properly designed they can also provide an improved appearance compared to a projecting entrance. The hydraulic efficiency of this type of concrete inlet depends on the geometry of the end-section to be used, as indicated in Table 11-3.

#### Mitered Inlets

Mitered inlets are simply culvert pipes cut with the slope of the embankment. They are most commonly used with corrugated metal pipes. The hydraulic efficiency of mitered inlets is dependent on the construction procedure used. Uplift is an important factor for a mitered inlet. Do not use mitered inlets with unpaved embankment slopes where the entrance may be submerged to a depth of more than 1.5 times the culvert rise.

#### Inlets to Long Culverts

While inlets are important in the design of short culverts, such as road crossings, they are even more significant in the economical design of long culverts and pipes. Unused capacity in a long culvert is a wasted investment. Long culverts are costly and require detailed engineering, planning, and design work. The inlets to these culverts are extremely important to the structure's functionality and require special attention.

Most long culverts require special inlet considerations to maximize the flow through the barrel of the culvert. Generally, for longer culverts, hydraulic model testing will result in better and less costly inlet construction. For additional considerations for long culverts, see the inset.

### Venting Considerations for Long Culverts

When hydraulic calculations indicate a Froude Number higher than 0.7 for flows up to and including the design flow, or when the culvert's entrance is submerged, the engineer must evaluate the need for adequate air vents along the culvert. Vents are necessary to minimize major pressure fluctuations that can occur if flow becomes unstable. Flow instability can result in negative pressures (less than atmospheric) in the culvert, surging flow, and other issues. Under this condition, air vents can mitigate and reduce structural loads and fluctuating hydraulic capacity in the culvert. Maintenance holes and storm inlets allow air to flow in and out of a culvert as it is filling and emptying. They also provide surface overflow outlets from the culvert when the design flow is exceeded, or the culvert is blocked.

A large rectangular culvert with a special entrance and an energy dissipater at the exit may need a maintenance hole that equipment can be lowered into in case major repair work becomes necessary. This can be a large, grated opening just downstream from the entrance. This grated opening can also serve as an air vent. Equipment may be lowered into the culvert by a crane or A-frame.

A long culvert must be easy to inspect; therefore, maintenance holes are desirable at various locations. If a rectangular culvert is situated under a curb, the maintenance hole may be combined with inlets. Align the opening with the vertical wall of the box to allow rungs in the riser and box to be aligned.

### Inlets to Rectangular Culverts

Entrances for rectangular culverts are especially important because the flow must be limited to avoid surcharging the conduit. Surcharging (pressurized flow) can cause the hydraulic grade line to exceed the road elevation, resulting in flooding, and can damage the culvert if not designed for the high velocities and additional pressure of these flow conditions. Special maximum-flow limiting entrances are often used with rectangular conduits. These special entrances should reject flow over the design discharge so that when a flow larger than the design flow occurs, the excess water will flow via other routes, often overland. A combined weir-orifice design is useful for this purpose. A second function of the entrance should be to accelerate the flow to the design velocity of the culvert, usually to meet the velocity requirements for normal depth of flow in the upstream reach of the culvert. For additional considerations for rectangular conduits, see the inset.

### Other Considerations for Rectangular Culverts

The use of rectangular culverts with high flow capacity can sometimes have cost advantages over large-diameter pipes. They can also be poured in place, providing flexibility in culvert dimensions. Consider the following when contemplating a rectangular culvert:

**Culvert Capacity:** The culvert's capacity drops significantly when the water surface reaches its roof since the wetted perimeter dramatically increases. The drop is 20% for a square cross section and more for a rectangular cross section where the width is greater than the height.

**Internal Pressure:** An obstruction, or even a confluence with another conduit, may cause the flow in a near-full rectangular culvert to strike the roof and choke the capacity. The capacity reduction may then cause the entire upstream reach of the culvert to flow full, with a resulting surge and pressure head increase of sufficient magnitude to cause a structural failure. When structural design has not been based on internal pressure, internal pressures are typically limited to no more than 2 to 4 feet of head. Surges or culvert capacity choking cannot be tolerated if the structure is not designed for the internal pressure resulting from these conditions. Thorough design is required to overcome this inherent potential problem.

**Air Entrainment:** Entrained air causes a swell in the volume of water and an increase in depth than can cause flow in the culvert to reach the height of the roof with resulting loss of capacity. Therefore, hydraulic design must account for entrained air. In rectangular culverts and circular pipes, flowing water will entrain air at velocities of about 20 ft/sec and higher. Additionally, other factors such as entrance condition, channel roughness, distance traveled, channel cross section, and volume of discharge all have some bearing on air entrainment. Volume swell can be as high as 20% (Hipschman, 1970).

**Slope and Alignment:** Structural requirements and efficiency for sustaining external loads, rather than hydraulic efficiency, usually control the shape of the rectangular conduit. A rectangular culvert should have a straight alignment and should not decrease in size or slope in a downstream direction. It is desirable to have a slope that increases in a downstream direction as an added safety factor against it flowing full. This is particularly important for supercritical velocities that often exist in long culverts.

**Curves and Bends:** The analysis of curves in rectangular culverts is critical to ensure adequate hydraulic capacity. When the water surface (normal, standing or reflecting waves) reaches the roof of the culvert, hydraulic losses increase significantly and the capacity drops. Superelevation of the water surface must also be investigated, and allowances must be made for a changing hydraulic radius, particularly in high-velocity flow. Analyze dynamic loads created by the curves to assure structural integrity for the maximum flows the culvert may experience. See the *Hydraulic Structures* chapter of the USDCM.

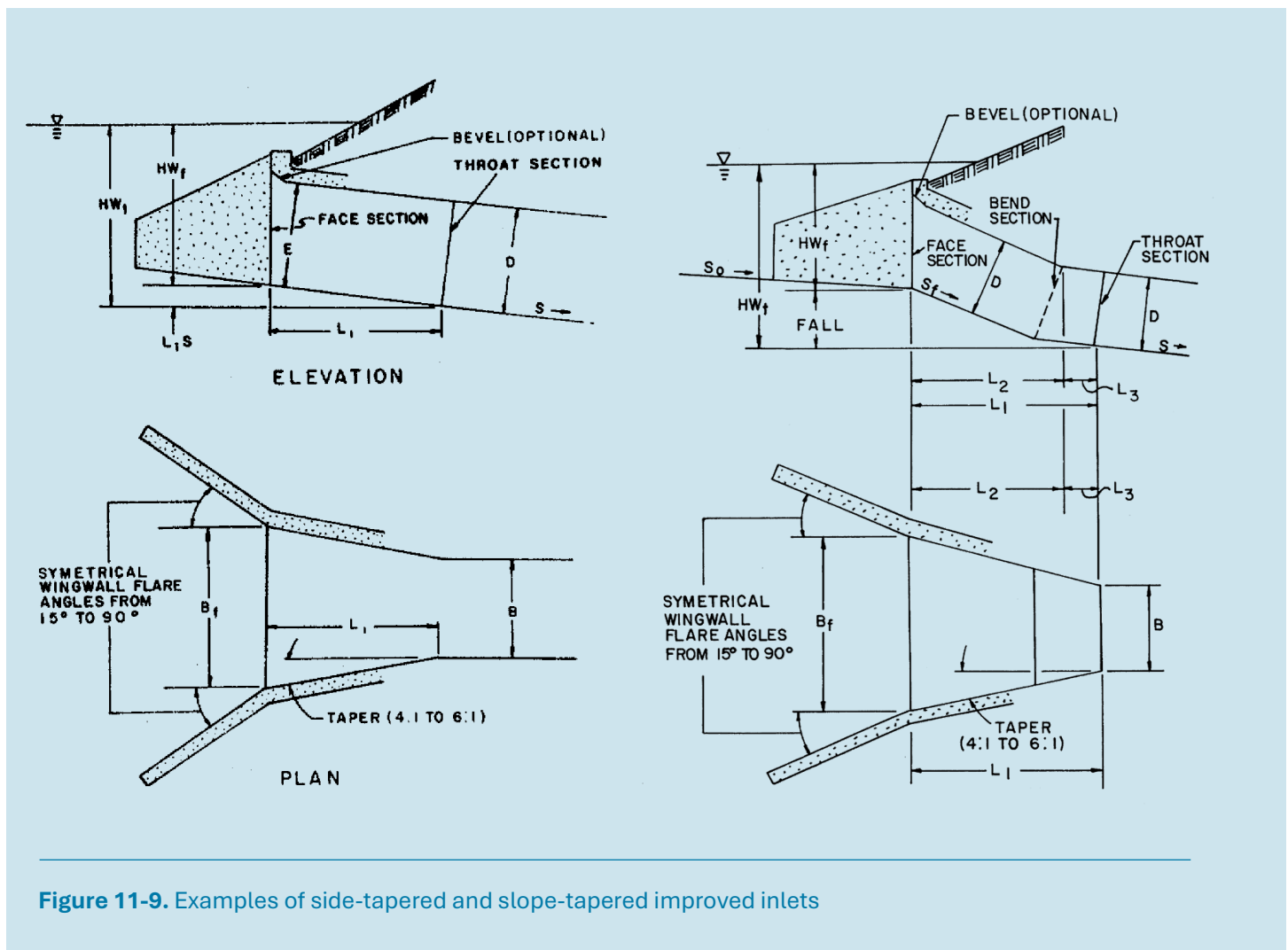
## Projecting Inlets

Do not use projecting inlets (protruding pipes at the inlet). Instead, use headwalls, wingwalls, and flared end sections to maximize efficiency and minimize turbulence, head loss, and erosion. This is especially important for flexible pipe materials (metal or plastic). This condition can cause severe suction and displacement of the pipe.

## Improved Inlets

Inlet edge configuration is one of the prime factors influencing the performance of a culvert operating under inlet control. Inlet edges can cause a severe contraction of the flow, as in the case of a thin edge, projecting inlet. In a flow contraction, the effective cross-sectional area of the barrel may be reduced to about one-half of the actual barrel cross-sectional area. As the inlet configuration is improved, the flow contraction is reduced, thus improving the performance of the culvert.

A tapered inlet is a flared culvert inlet with an enlarged face section and a hydraulically efficient throat section. Tapered inlets improve culvert performance by providing a more efficient control section (the throat). However, tapered inlets are not recommended for use with culverts flowing under outlet control because under outlet control, the simple beveled edge is of equal benefit. The two most common improved inlets are the side-tapered inlet and the slope-tapered inlet, as illustrated in Figure 11-9. FHWA's HDS 5 (2012) provides guidance on the design of improved inlets.



**Figure 11-9.** Examples of side-tapered and slope-tapered improved inlets

## 5.2 INLET PROTECTION

Culvert inlets, especially those on live streams, should be evaluated relative to debris control and buoyancy.

### 5.2.1 Debris Management

Accumulation of debris at a culvert entrance reduces the conveyance capacity of the culvert and increases the headwater depth required to pass the design flow rate. This can create hazardous conditions due to road overtopping, inundation of upstream property, and/or flooding of property. The designer has four general options for addressing the issue of debris plugging a culvert:

- Retain the debris upstream of the culvert.
- Attempt to pass the debris through the culvert.
- Install a bridge to create more cross-sectional area for passage of debris.
- Relocate the crossing to a geomorphically appropriate location where the reach is relatively stable with a consistent gradient and minimal skew in the alignment. Refer to MHFD's *Geomorphically Informed Stream Crossing Structures* guidance document (ICON Engineering, 2025) for additional information.

If the debris is to be retained by an upstream structure or by a grate at the culvert inlet, frequent maintenance will be required. The design of a debris control structure should include a thorough study of the debris problem and should consider the factors listed in the text box below.

#### Debris Study Considerations

Factors to be considered in a debris study include:

- Type of debris (large woody debris, small woody debris, urban trash, boulders, etc.).
- Quantity of debris and flow rate and volume bulking effects - see *Caltrans' Highway Design Manual, Chapter 810 – Hydrology* for guidance on bulking factors (Caltrans, 2020).
- Alternate overland flow path(s) (under plugged conditions) – the depths and extents of the overland flow path(s) should be quantified to assess potential for hazardous depths and velocities and potential flooding damages.
- Expected changes in type and quantity of debris due to future development of the watershed.
- Velocity in the vicinity of culvert entrance and overflow depths and velocities.
- Maintenance plan for debris removal (during and between events) and safety of maintenance personnel.
- Availability of upstream storage areas with maintenance access.
- Potential for damages due to debris clogging, if protection is not provided.
- Potential safety implications of a grated versus un-grated culvert entrance.

Refer to Hydraulic Engineering Circular No. 9, *Debris Control Structures Evaluation and Countermeasures* (HEC-9, FHWA 2005), when designing debris control structures. The Colorado Water Conservation Board (CWCB)'s *Stream Crossing Assessment and Design for Post-Fire Conditions* fact sheet (CWCB, 2024) also provides guidance related to managing debris at culverts for burned and unburned watershed conditions.

## 5.2.2 Buoyancy

The forces acting on a culvert inlet vary as the hydrograph rises and falls in a runoff event. When a culvert functions under inlet control, an air pocket forms just inside the inlet, creating a buoyant effect when the inlet is submerged. The buoyancy forces increase with an increase in headwater depth under inlet control conditions. These forces, along with vortices and eddy currents, can cause scour, undermine culvert inlets, and erode embankment slopes, thereby making the inlet vulnerable to failure, especially if deep headwater conditions are present.

In general, installing a culvert in a natural stream channel constricts the normal flow. The constriction is accentuated when the capacity of the culvert is impaired by debris or damage. The large unequal pressures resulting from inlet constriction are, in effect, buoyant forces that can cause entrance failures, particularly on corrugated metal pipe with mitered, skewed, or projecting ends. The failure potential increases with steepness of the culvert slope, depth of headwater, flatness of the fill slope over the upstream end of the culvert, and the depth of the fill over the pipe.

Anchoring the culvert entrance helps to protect against these failures by increasing the deadload on the end of the culvert, protecting against bending damage, and protecting the fill slope from the scour. Use a standard concrete headwall or end wall to help counteract the hydrostatic uplift and to prevent failure due to buoyancy.

Because of a combination of high head on the outside of the inlet and the large region of low pressure on the inside of the inlet, the end of the culvert can experience a large bending moment, which may result in failure. This problem has been noted for culverts under high fills, on steep slopes, and with projecting inlets. Consult with geotechnical and structural engineers under these conditions. In cases where upstream detention storage is necessary and the headwater depth exceeds 20 feet it is better to restrict discharge by reducing the culvert size rather than using an inefficient projecting inlet.

## 5.3 SAFETY GRATES

Every year in the U.S., multiple people and often children and first responders, die from being swept into culverts that have open entrances. Many of these fatalities could be avoided by providing properly designed and maintained safety grates at hazardous culvert entrances. Small circular pipes (where a person can become stuck in the culvert) and long culverts, especially those with bends that can entrap people, pose some of the most hazardous conditions. This section provides criteria for when safety grates are required, how they should be designed, and how grates should be evaluated along with other potential hazards.

### Culvert and Pipe Related Fatalities

MHFD's *Technical Memorandum on Safety Grates Recommendations for Circular Pipes* (MHFD, 2024) includes documentation of nearly 40 fatalities related to pipes and culverts from 1996 – 2024. Of the injuries and deaths documented, most incidents have been related to smaller circular pipes ranging from a 12-inch to 54-inch diameter. In these instances, most victims were either playing in water or attempting to cross ponded water. The victims were primarily children (aged 6 to 17) and first responders. In many of these cases, the pipe opening was unprotected, and victims inadvertently entered or were pulled into the storm drain. In fewer cases, the storm drain opening was protected by a grate; however, the victims were unable to remove themselves from the grate. The total number of occurrences is unknown as there is no official agency that tracks how many Americans get pulled into storm drains or culverts during flood events. ProPublica identified 35 cases since 2015 using news accounts and court records. They reported that 21 of these people died and nearly half of those lost were children (ProPublica 2021).

## 5.3.1 Culvert Entrances with Design Flows up to 300 CFS

To develop improved criteria for circular culvert entrances, MHFD partnered with Colorado State University's Hydraulics Laboratory (CSU), AECOM, and Larimer County Dive Rescue Team from 2022 to 2024 to conduct flume tests and computational fluid dynamics modeling to assess various culvert grate configurations and determine conditions that limited a person's ability to self-rescue. This study focused on circular culverts. The details of these field tests and hydraulic modeling efforts are detailed in two publications:

- CSU, 2024. Physical Model Flume Tests of Storm Drain Safety Grates.
- AECOM, 2024. Storm Drain Safety Grates: Computational Fluid Dynamics Modeling Report.

MHFD's *Technical Memorandum on Safety Grates Recommendations for Circular Pipes* (MHFD, 2024) provides the results of these studies and criteria for circular pipes, summarized in Table 11-4. Based on this study, smaller circular pipes are especially dangerous. Although the 2024 study did not evaluate rectangular (box) culverts or elliptical pipe entrances, for design flows up to 300 cfs, MHFD recommends treating these similarly to circular entrances.

**Table 11-4.** Types of safety grate required for circular pipes of varying design discharge and headwater to diameter ratios (HW/D)

Culvert Condition (Design Discharge and Hw/D)	Open Pipe (No Grate)	Prefabricated Flared End Section with Prefabricated Grate	Grate per MHFD Design
Design Discharge < 20 cfs and HW/D ≤ 1.5	suitable	suitable	suitable
20 cfs < Design Discharge < 100 cfs and HW/D ≤ 1.5	not suitable	suitable	suitable
HW/D > 1.5 or 100 cfs < Design Discharge < 300 cfs	not suitable	not suitable	suitable

The MHFD grate design referenced in Table 11-4 is a grate that is offset 12 inches from the face of the pipe opening, has a 1:1 slope, and bar spacing 5-inches clear (Photograph 11-4). The 12-inch offset serves to increase the distance between the culvert entrance and a person, which reduces the force exerted on a person and provides a step to aid in self-rescue or a place for a first responder to stand while assisting a person attempting to remove themselves from the grate. Transverse support bars located at the back of the grate need to be as few as possible, but sufficient to keep the grate from collapsing under full hydrostatic loads. Design grating to satisfy two loading conditions with a deflection of 1/4 inch or less, 1) a uniform load of 100 pounds per square foot and 2) a concentrated load of 200 pounds applied at the center of the span. Figure 11-10 is a conceptual detail of the MHFD Safety Grate.

### 5.3.2 Design Flows Exceeding 300 CFS including Box Culvert Entrances

For culverts with design discharges exceeding 300 cfs, conduct a site specific analysis considering the factors discussed in this section and included in the inset on the following page to determine if a safety grate is warranted and if so, what type of grate to use. Grates of this size may require specialized structural design due to the weight of the structure and hydraulic forces on the grate.

Always consider the use of safety grates at inlets to culverts and underground pipes where intended or unintended entry by a person could be dangerous. While safety grates help protect the public from entering culverts, on streams with high debris loads, grates can become obstructed, leading to flooding problems and/or safety risks to maintenance staff clearing debris during a flood event. In these situations, a multi-factor decision making approach is useful to consider the hazards posed over the range of flow rates analyzed. The intent is to evaluate hazards associated with a person entering the culvert compared to the hazards related to debris on the grate. This allows decision makers to consider the frequency of various hazards such as drowning, flooding, injury or death of maintenance personnel, hazardous road conditions, and others. If the ultimate decision is to forego a safety grate due to other hazards outweighing the culvert drowning hazard, at a minimum, strongly worded signage must be provided to warn the public. In park settings, also consider how the area around the culvert entrance can be restricted or closed to the public during flood events. Documentation of the decision-making approach and different hazards considered is essential.

Frequently, box culverts are used for high design flows. Many box culverts have sufficient cross-sectional area and short enough lengths that safety grates are not needed. However, for box culverts that are long (cannot see from one end to the other), or those with



**Photograph 11-4.** A safety grate used in the CSU flume study, designed per MHFD criteria.

#### Key Findings from Safety Grate Physical Flume Research

- When the force on a human subject exceeds 110 lbf in the flow direction, the subject may find it difficult to free themselves from a safety grate.
- A safety grate with a 1:1 (horizontal: vertical) slope and 12-inch offset from the face of the pipe orifice was suitable (did not exceed the design threshold of 110 lbf) in all conditions tested in the flume.
- Horizontal bars placed behind the sloped portion of the grate did not increase a person's ability to self-rescue and may restrict mobility during rescue.

bends or potential utility crossings, the risks of entrapment and drowning are much higher. Evaluate the need for a safety grate in these situations.



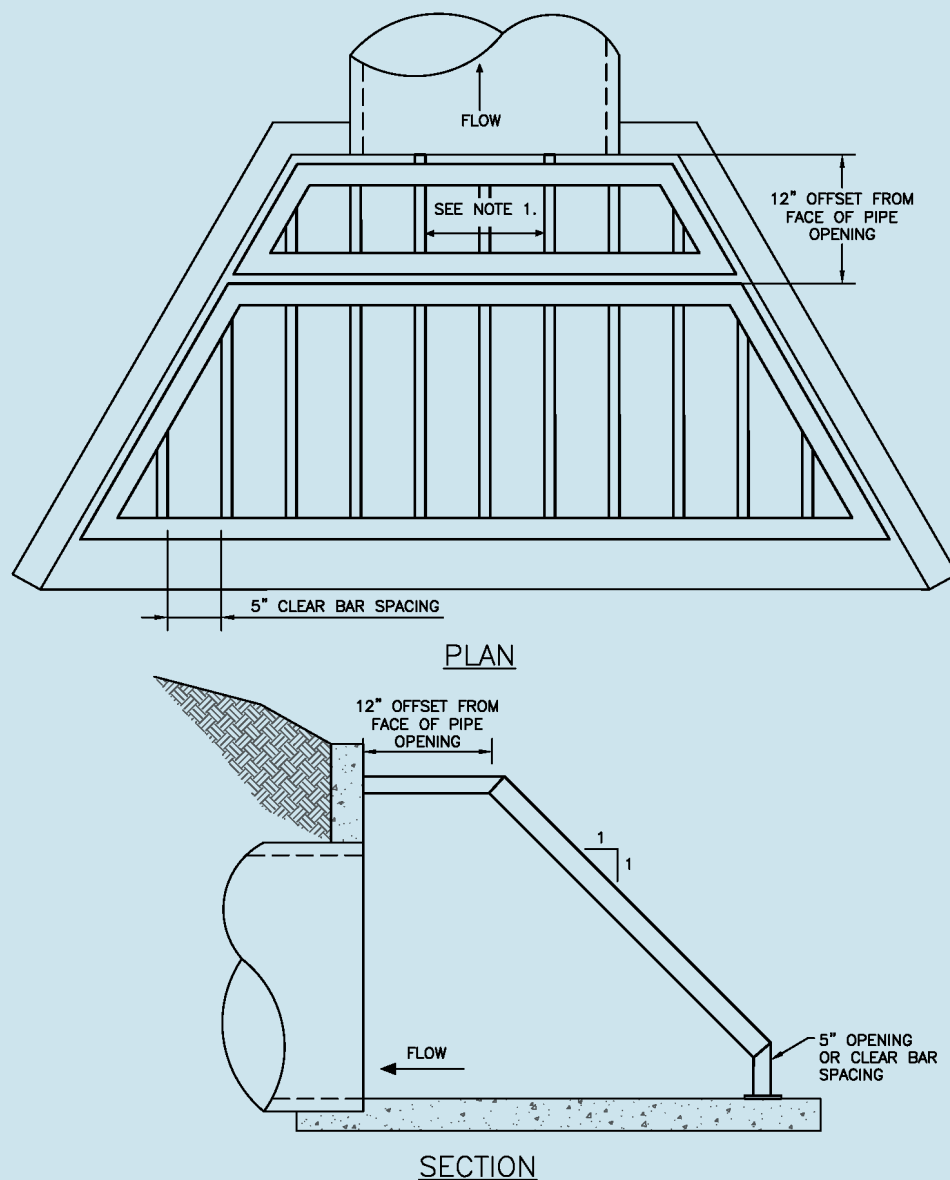
**Photograph 11-5.** A grated outlet poses a risk to those that enter the storm drain and requires more frequent maintenance. Evaluate all risks and place grates on an outlet only as a last resort. Photo courtesy of City and County of Denver.

### Safety Grate Design

- For design flows 300 cfs and below, refer to Table 11-4 for suitable safety grate configurations.
- For box culverts and circular culverts exceeding 300 cfs, review hazards related to the depth and velocity of flow, frequency and conditions under which the hazard occurs, surrounding site features, the condition of the site during high water (i.e., what will be visible to someone that may be unfamiliar with the site and what will be hidden), the length and size of the culvert, and other similar factors.
- For box culverts where there is not a clear line of sight from the entrance to the exit of the culvert, evaluate the need for a safety grate based on factors including length of culvert, bends and junctions, debris characteristics, outlet conditions, first responder and maintenance personnel access and safety, risk of floodings, and similar considerations.
- For custom safety grates ensure a net open area of 4 times the culvert-entrance area.
- Make bar openings 5-inches clear to reduce foot entrapment and allow passage of small debris.
- Design a clear opening at the bottom of no more than 5 inches. Where the bottom surface is vegetated or uneven, openings may vary and exceed this dimension. The intent is to reduce potential for a person to be swept under the grate. Where design flow exceeds 300 cfs and debris flows are significant, risk of clogging and overtopping and risks to maintenance personnel may be present. Compare relative risks to determine if a larger clear space at the bottom is needed for debris. Mitigate risks where possible.
- Orient bars on the face of the grate with the direction of flow to minimize hydraulic losses and facilitate maintenance of debris.
- Evaluate hydraulics of the grate to avoid forces that could pin a person to the face of the grate (AECOM, 2024 and Guo et al., 2010). A large, sloped grate anchored well in front of the culvert entrance, such as the MHFD grate, reduces the risk of pinning.
- Provide maintenance access behind the grate. Access could be via a maintenance hole behind the headwall, a hatch within the grate, or a hinged grate. Consider locking the access where appropriate.

### 5.3.3 Outlet Grating

Evaluate risks to human life and only install grating at the outlet of a culvert or storm drain as a last resort because a person swept into the culvert will be trapped inside the grate where they will face certain death (Photograph 11-5). Additionally, debris will impinge against the grate and cause significant flow capacity reductions and potentially flood upstream areas. Pressurization in the pipe can also result in an unreasonable risk to the health and safety of the public. Where outlet grating cannot be avoided due to other public safety concerns, ensure access into the storm drain system is restricted in all other potential entry locations and install signage to warn of extreme danger if entered.



**NOTES:**

1. DESIGN GRATING TO SATISFY TWO LOADING CONDITIONS WITH A DEFLECTION OF 1/4 INCH OR LESS: 1) A UNIFORM LOAD OF 100 POUNDS PER SQUARE FOOT AND 2) A CONCENTRATED LOAD OF 200 POUNDS APPLIED AT THE CENTER OF THE SPAN.
2. SAFETY GRATES MUST HAVE A NET OPEN AREA (EXCLUDING THE BARS) OF 4 TIMES THE CULVERT-ENTRANCE AREA.
3. ACCESS TO THE PIPE FOR MAINTENANCE AND DEBRIS REMOVAL IS REQUIRED.

**Figure 11-10. Conceptual MHFD Safety Gate**

### 5.3.4 Collapsible Grating

MHFD does not generally recommend the use of collapsible grating because of the risk of the mechanism getting jammed or clogged, reducing the effectiveness of the inlet and creating a safety risk. Nevertheless, on larger culverts where grating is found to be necessary, the use of collapsible grating may be desirable. Such grating must be carefully designed from the structural standpoint so that collapse is achieved with a hydrostatic load of approximately one-half of the maximum allowable headwater. The collapse of the grate should be such that it clears the waterway opening adequately to permit the inlet to function properly.

### 5.3.5 Upstream Debris Collectors

In lieu of a collapsible grate and where a safety hazard exists, a grate for debris collection situated a reasonable distance upstream from the actual inlet is often satisfactory. This type of grating may be a series of vertical pipes or posts embedded in the approach channel bottom. If blocking of this grating occurs, the backwater effect causes water to flow over the top of the grating and into the culvert with only minimal upstream backwater effect. The grating must not be so high as to cause the water to rise higher than the maximum allowable elevation.

## 6.0 OUTLET PROTECTION



**Photograph 11-6.** Energy dissipation and outlet protection are essential to promote channel stability.

The high velocity of flow through a culvert often creates the potential for scour at culvert outlet and mitigation against erosion is required (Photograph 11-6). This section provides background information and speaks to the complexity of this transitional area. See the *Hydraulic Structures* chapter for detailed discussion and details of outlet protection practices.

Compared to the stream, flow in a culvert barrel is usually confined to a lesser width and greater depth. This results in increased velocity and potential erosion as flow exits the barrel. Turbulence and erosive eddies form as the flow expands into the downstream channel. However, the velocity and depth of flow at the culvert outlet and the velocity distribution upon reentering the stream are not the only factors that must be considered.

The characteristics of the stream bed and bank material, velocity, and depth of flow in the stream at the culvert outlet (tailwater), and the amount of sediment and other debris in the flow are all contributing factors to scour. Scour prediction is not an exact science due to the variability of flow rates both between different events and within a single runoff event, as well as the challenges in evaluating the hydraulics of rapidly changing flow.

As discussed in the *Hydraulic Structures* chapter, riprap channel expansions and concrete aprons stabilize the transition and redistribute or spread the flow. Barrel outlet expansions operate in a similar manner. Headwalls and cutoff walls protect the integrity of the fill. At some locations, use of a rougher culvert material may alleviate the need for a special outlet protection device by limiting velocities in the barrel of the culvert. When outlet velocities are high enough to create excessive downstream problems, consider using energy dissipation devices such as stilling basins, streambed level dissipators, riprap basins and aprons, drop structures, or stilling wells. Design information for the general types of energy dissipators is provided in the *Hydraulic Structures* chapter of the USDCM and in *Hydraulic Design of Energy Dissipators for Culverts and Channels* (HEC-14, FHWA, 2006).

# 7.0 BRIDGES

## 7.1 GENERAL

Bridges are used to carry roadways, railroads, shared-use paths (Photograph 11-7), and utilities over surface waters. In some cases smaller bridges may behave hydraulically like culverts if they become pressurized or submerged. If a bridge is not sized properly, overtopping and flooding will occur, leading to public hazards, erosion damage, and possible structural failure. All bridge projects involve an assumption of a certain level



**Photograph 11-7.** Bridges for a shared-use path.

of risk typically determined by the owner or local jurisdiction based on the design event(s) specified for different street classifications. This section provides a brief overview of hydraulic design of bridges and includes references for additional design guidance. Structural design is not addressed in this manual, refer to the American Association of State Highway and Transportation Officials (AASHTO) Standard Specifications for Highway Bridges (AASHTO, 2002) for this information.

There are many references for bridge hydraulics. A key source of information is the FHWA. To view a list of FHWA references go to: [http://www.fhwa.dot.gov/engineering/hydraulics/library\\_listing.cfm](http://www.fhwa.dot.gov/engineering/hydraulics/library_listing.cfm). Be sure to use the most recent version of a publication as FHWA, CDOT, and AASHTO periodically update criteria.

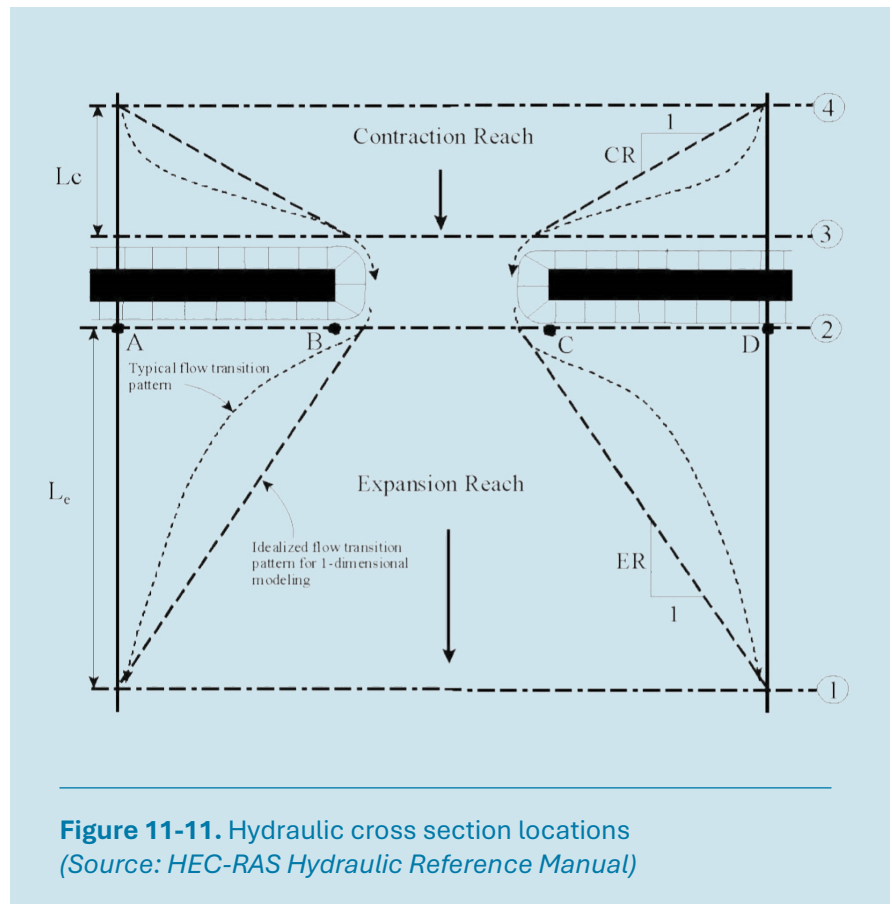
Some of the key references for bridge hydraulics published by FHWA and others include:

- FHWA, *Hydraulic Design of Safe Bridges*, Hydraulic Design Series No. 7 (HDS 7), 2012.
- FHWA *Highways in the River Environment: Roads, Rivers, and Floodplains*, Second Edition, HEC-16, 2023.
- FHWA, *Highways in the River Environment: Floodplains, Extreme Events, Risk, and Resilience*, Second Edition, HEC-17, 2016.
- FHWA, *Evaluating Scour at Bridges*, Fifth Edition, HEC-18, 2012.
- FHWA, *Stream Stability at Highway Structures*, Fourth Edition, HEC-20, 2012.
- FHWA, *Design of Bridge Deck Drainage*, HEC-21, 1993.
- FHWA, *Bridge Scour and Stream Instability Countermeasures Experience, Selection, and Design Guidance*, Volumes 1 and 2, Third Edition, HEC-23, 2009.
- CDOT, 2019. *Drainage Design Manual, Chapter 10: Bridges*.
- AASHTO, *Highway Drainage Guidelines, Chapter 7: Hydraulic Analysis for the Location and Design of Bridges*, 2007.

Most roadway bridges are designed to pass the 100-year flood event. However, other types of bridges (such as for shared-use paths) may allow for more frequent overtopping. Verify the design event(s) for the bridge with the owner and local government. If a bridge is located within a regulatory floodplain, analyze the effects of the bridge on upstream water surface elevations and velocities through the structure using HEC-RAS or comparable calculations. An advantage of using HEC-RAS for hydraulically sizing a bridge is that the program can also evaluate scour. Contact the local government to determine floodplain permitting requirements. At a minimum a floodplain development permit will be required, and in many cases a CLOMR/LOMR will be needed.

## 7.2 BACKWATER AND HYDRAULIC ANALYSIS

To the extent feasible, design bridge openings and embankments to minimize impacts to the flow characteristics in the stream channel and floodplain. Bridge abutments and embankment fills in the floodplain and piers in the floodway constrict flow and cause a backwater effect upstream. Most bridges are designed to pass design flows with freeboard between the design upstream water surface elevation and the low chord of the bridge; however, backwater effects may affect upstream structures and sediment transport characteristics through the bridge. For purposes of regulatory floodplain modeling and backwater analysis, analyze subcritical flow conditions. When needed for scour evaluation, use a mixed flow regime to evaluate maximum velocities. HEC-RAS is recommended for analysis of bridge hydraulics and backwater effects, as it incorporates the latest hydraulic and scour calculations from FHWA.

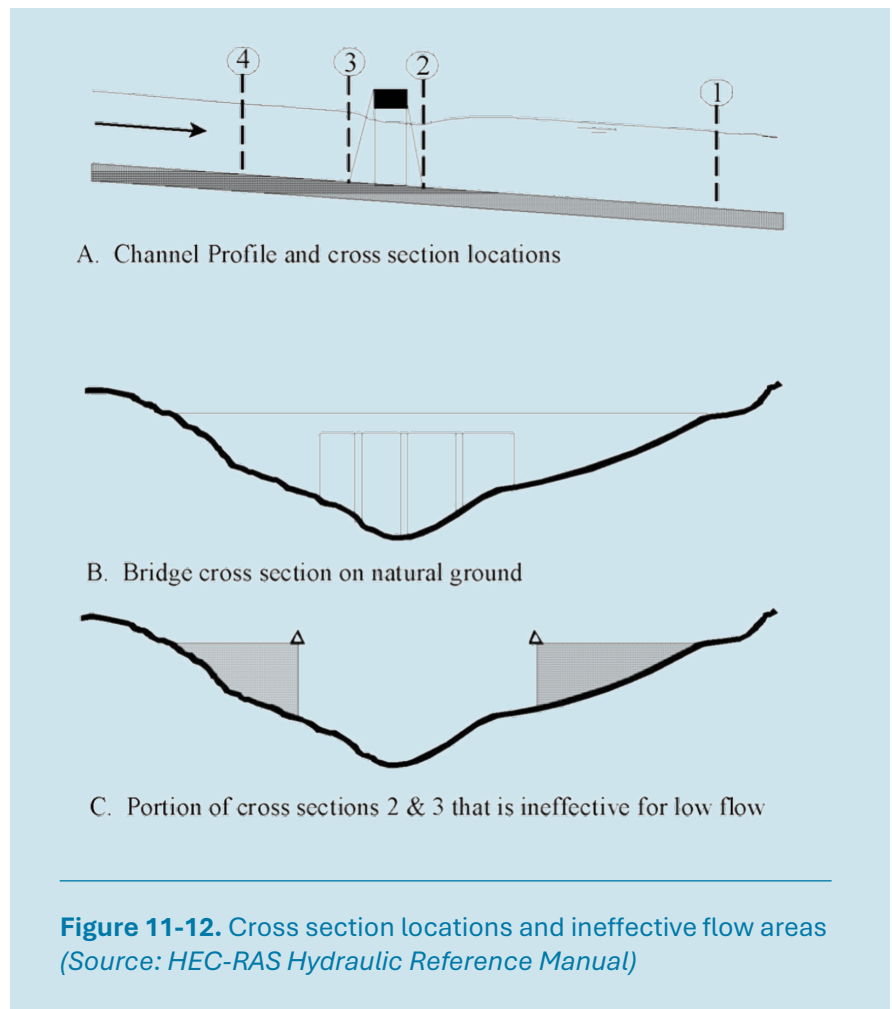


The HEC-RAS User's Manual and Hydraulic Reference Manual (available through the USACE's HEC RAS website) provide a thorough description of the input parameters required for the model and the technical basis for calculations. One of the most fundamental aspects of modeling a bridge (or a culvert) is the layout of the cross sections upstream and downstream of the bridge. Figure 11-11 and Figure 11-12 illustrate the proper layout of cross sections at a bridge. This layout is needed to represent the contraction and expansion of the flow as it enters and leaves the bridge. The contraction and expansion zones create ineffective flow areas to either side of the bridge opening for a relatively short distance upstream and downstream, as illustrated in Figure 11-12. Increase expansion and contraction coefficients to account for additional energy losses due to rapid change in velocities for cross sections upstream and downstream of the bridge. See the HEC-RAS Hydraulic Reference Manual for guidance on cross section locations, contraction and expansion ratios (CR and ER in Figure 11-11), ineffective flow areas, and contraction and expansion coefficient adjustments.

## 7.3 FREEBOARD

Unlike culverts, which are typically designed with a headwater elevation above the top of the structure, bridges are designed to have freeboard between the design water surface elevation and the low chord of the bridge. Freeboard for bridges is critical because the heavy debris carried in a major flood can permanently damage the structure if it is not passed through the bridge, potentially leaving an important roadway out of service.

Bridge freeboard is the vertical distance between a design water surface elevation and the low chord of the bridge superstructure. Freeboard accounts for a reasonable degree of uncertainty of the design flow rate and allows for passage of ice, debris, and waves during a flood event. Criteria for bridge freeboard vary from 1-foot to 4-feet in Colorado depending on the jurisdiction and risk of debris specific to the stream. CDOT recommends minimum freeboard of 2 feet for low-to-moderate debris streams and 4 feet or more for high-debris streams (CDOT, 2019). Add the freeboard to the water surface elevation approximately 50 to 100 feet upstream of the face of the bridge to get the bottom or low-girder elevation (CDOT, 2019). Additionally, some criteria define freeboard based on the geometry of the bridge (e.g., CDOT provides figures for measuring freeboard for bridges with a vertical curve and continuous grade). When the local government does not have bridge freeboard criteria, refer to CDOT, CWCB, or AASHTO and confer with the local government to determine appropriate freeboard criteria (CDOT 2019, CWCB 2008, AASHTO 2002).



## 7.4 BRIDGE SCOUR ANALYSIS

The increased flow velocities at a bridge constriction often lead to scour, which is of particular concern because it can undermine a bridge's foundations and potentially cause collapse of the structure. Established methodologies for estimating scour at bridges and designing countermeasures are contained in FHWA HEC-18, HEC-20, and HEC-23 (available at [www.fhwa.dot.gov/engineering/hydraulics/](http://www.fhwa.dot.gov/engineering/hydraulics/)).

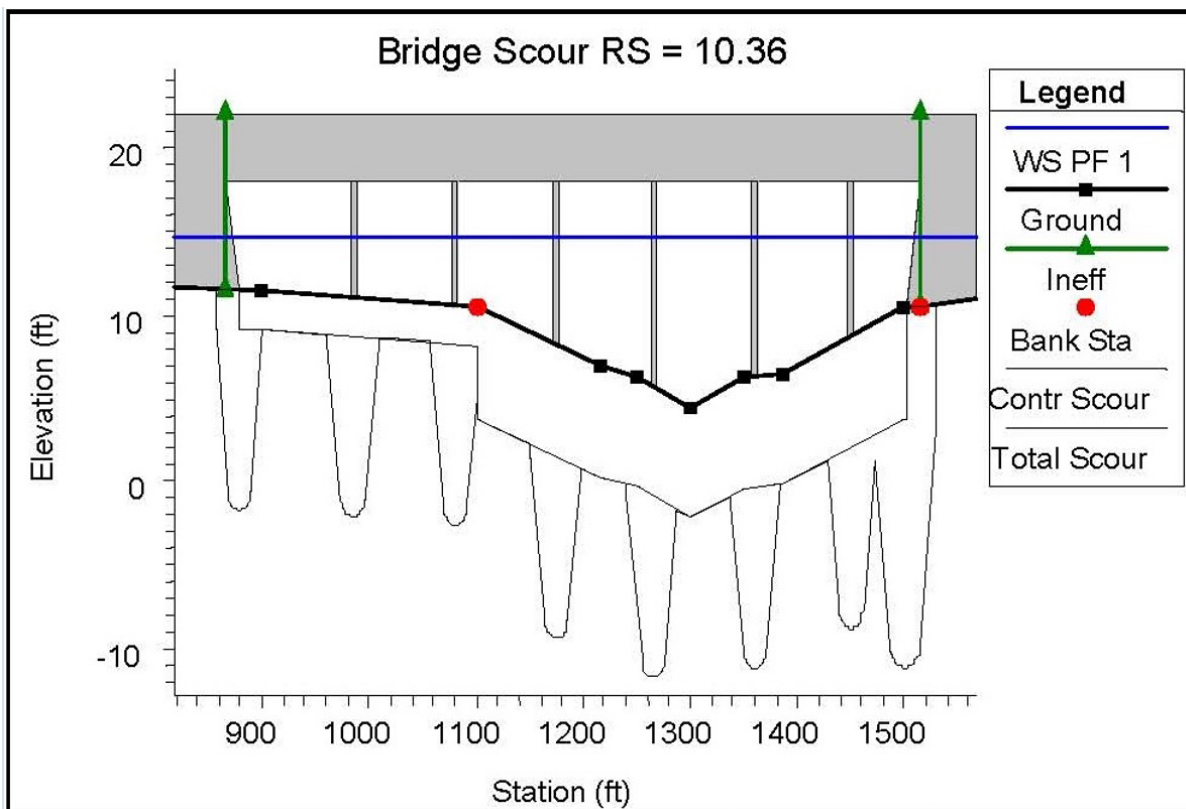
The methods described in the 2001 version of HEC-18 (FHWA, 2001) and HEC-20 are incorporated into the HEC-RAS computer program in its Hydraulic Design/Scour module. The program automatically calculates many of the input parameters for scour routines based on the program's hydraulic output around the bridges. For gradation inputs, collect samples of bed and bank material upstream of, through and downstream of the structure and use a representative value or perform a sensitivity analysis if there is wide variability in gradation data.

When using HEC-RAS for scour calculations, it is critical to understand the input including cross section and output parameters, applicability and limitations of different scour methods, and whether the resulting values are reasonable. This can depend on the way data are imported for bridge geometry, bank stations, and other input variables.

When using HEC-RAS for scour calculations, it is critical to understand the input and output parameters, applicability and limitations of different scour methods, and whether the resulting values are reasonable. This can depend on the way data are imported for bridge geometry, bank stations, and other input variables. Localized bridge scour is comprised of:

- Contraction scour
- Local pier scour
- Local abutment scour

These three components are added together to arrive at a final scour envelope, as illustrated in Figure 11-13, an example of HEC-RAS scour output for a bridge with six piers and sloping abutments.



**Figure 11-13.** Example of scour envelope, as calculated with HEC-RAS  
(Source: HEC-RAS Hydraulic Reference Manual)

FHWA recommends calculation of scour for piers and abutments with the absence of riprap at roadway bridges. Reliance upon riprap for overall bridge stability and foundation design is not advised. However, riprap is often used as a scour countermeasure. FHWA provides guidance on selecting and designing scour countermeasures, including riprap at bridge piers and abutments in HEC-23 *Bridge Scour and Stream Instability Countermeasures, Experience, Selection, and Design Guidance* (FHWA, 2009).

It is important to note that the above methodology for calculating scour assumes that unconsolidated alluvial material makes up the channel bottom within the scour envelope. If bedrock is located within the scour envelope, or especially if bedrock is exposed at the surface of the channel bottom, other methodology should be used to determine the bedrock erodibility. The Erodibility Index Method was developed to evaluate scour in bedrock and is described in *Scour Technology: Mechanics and Engineering Practice* (Annandale, 2006).

A scour analysis must address long-term patterns of channel change. An understanding of fluvial geomorphology is important in determining this portion of the analysis. This includes evaluation of sediment transport, patterns of channel invert or overbank lowering (degradation), patterns of deposition (aggradation), and lateral migration. Aggradation can lead to loss of capacity under a bridge, and degradation can cause undermining of a bridge foundation. In the case of long-term degradation of a channel, consider grade control structures downstream of the bridge. However, local scouring around a bridge's structural elements can still occur even with grade control structures. Long term aggradation may indicate the need for upstream bed and bank stabilization measures to reduce sediment loading. While the latest versions of HEC-18, HEC-20, and HEC-23 provide the basis for evaluating scour, stream stability, and countermeasures for bridges, FHWA and the National Cooperative Highway Research Program (NCHRP) continue to study scour at bridges.

### Ongoing Bridge Scour Research

Resources and information on updates to bridge scour methods and criteria can be found at:

- FHWA Scour Technology Program: <http://www.fhwa.dot.gov/engineering/hydraulics/scourtech/index.cfm>.
- NCHRP Research Field 24 – Foundations and Scour: <http://www.trb.org/NCHRP/NCHRPProjects.aspx>. Many of these advancements were incorporated into the 2012 version of HEC-18.

## 8.0 DESIGN EXAMPLE

This section demonstrates culvert sizing using HY-8, the method applicable to many culvert sizing applications that are not affected by upstream or downstream hydraulic structures. This example sizes a culvert given the following information:

- $Q_{5\text{-yr}} = 20$  cfs
- $Q_{100\text{-yr}} = 35$  cfs
- $L = 95$  ft
- Maximum allowable  $H_w = 5288.5$  ft
- Culvert shape is circular
- Channel invert elevations:
  - Inlet = 5283.5 ft
  - Outlet = 5281.5 ft
- Tailwater depth, 5-year storm = 2.5 ft
- Tailwater depth, 100-year storm = 3.0 ft
- Excavated trapezoidal channel with gravel (uniform section, clean), 2:1 side slopes, bottom width = 10 ft

This section guides the user through the typical steps to set up and run a model in HY-8. To begin, start a new project by adding a “Crossing” with the information in Table 11-5. Figure 11-14 shows the input interface window. Once all the inputs are entered, the culvert may be analyzed using “Analyze Crossing” button near the bottom right corner of the box shown in Figure 11-14. This should generate an output screen that looks like Figure 11-15. If any critical input values are missing, the program will not execute properly.

HY-8 provides extensive output for modeled culverts and has options for exporting reports and generating rudimentary figures. Please refer to the HY-8 User’s Manual for further interpretation of model output and options for presenting results.

**Table 11-5. HY-8 program inputs**

Parameter	Value	Source
Min Flow (cfs)	0.0	User-specified, usually 0.0 for developing a performance curve
Design Flow (cfs)	Q <sub>5-yr</sub> or Q <sub>100-yr</sub>	User specified based on local criteria
Max Flow (cfs)	35	Usually set for event that overtops roadway
Channel Type	Trapezoidal Channel	Select channel type to represent downstream channel characteristics
Bottom Width (ft)	10	Downstream channel geometry
Side Slope (H:V) (_:1)	2	Downstream channel geometry
Channel Slope	0.03 ft/ft	Downstream channel geometry
Manning's n (channel)	0.025	Downstream channel bed and bank roughness characteristics
Channel Invert Elevation (ft)	5283.5	Downstream channel topography or grading
Roadway Profile Shape	Constant Roadway Elevation	Civil design input, must be coordinated with bridge opening height
First Roadway Station (ft)	0	Civil design input, set at 0 for preliminary calculations, use road stationing for final design
Crest Length (ft)	100	Civil design input, often approximated as broad weir for preliminary calculations, use topography/grading for final design
Crest Elevation (ft)	5288.5	Civil design input, must be coordinated with bridge opening height
Roadway Surface	Paved	Civil design, paved typical
Top Width (ft)	150	Civil design, can be approximated for preliminary design based on culvert length and roadway side slopes
Shape	Circular	Design parameter
Material	Concrete	Design parameter
Diameter	2.0 feet	Design parameter
Embedment Depth	0	Design parameter
Manning's n	0.012	User specified based on material
Culvert Type	Straight	User specified, HY-8 has multiple options
Inlet Configuration	Square edge with headwall (Ke=0.5)	User specified, HY-8 has multiple options
Inlet Depression?	No	User specified, depression may be used to increase inlet capacity
Inlet Station	0	Typically set at 0 for preliminary analysis, use stream stationing for final design
Inlet Elevation	5283.5	User specified
Outlet Station	95	Inlet station + length of culvert
Outlet Elevation	5281.5	User specified
Number of Barrels	1	User specified, HY-8 can model multiple barrels

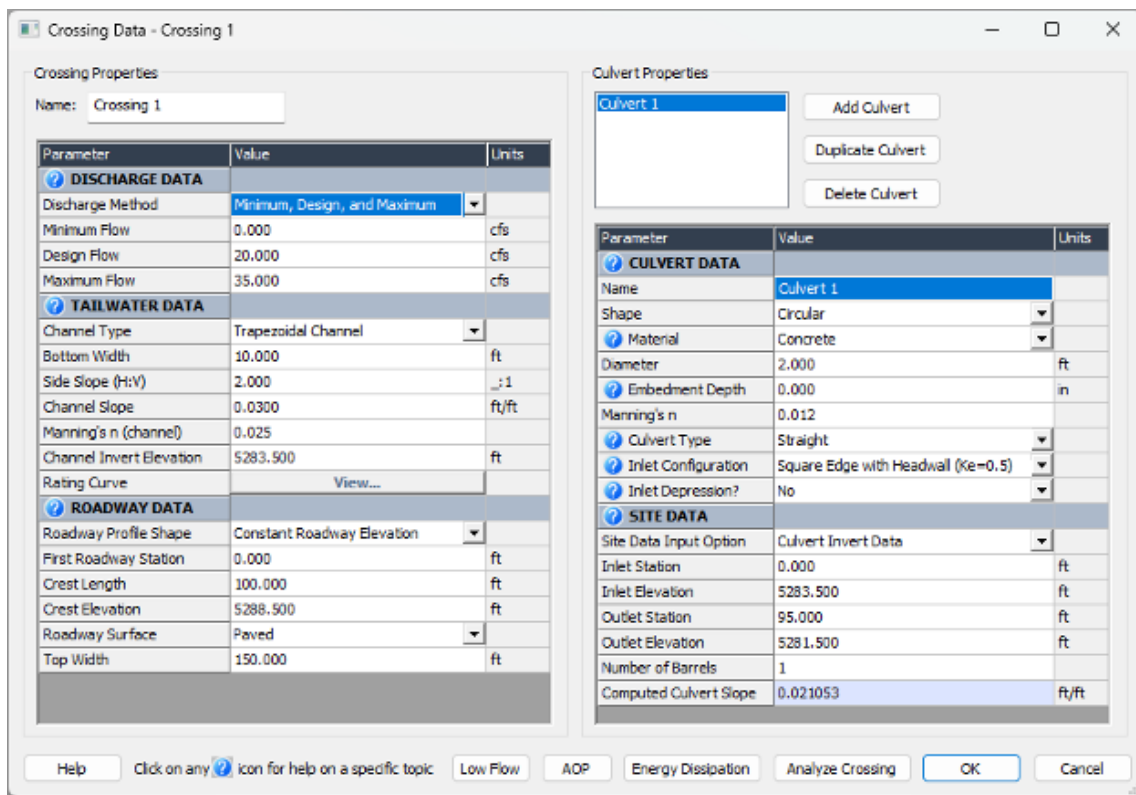


Figure 11-14. Adding a crossing in HY-8

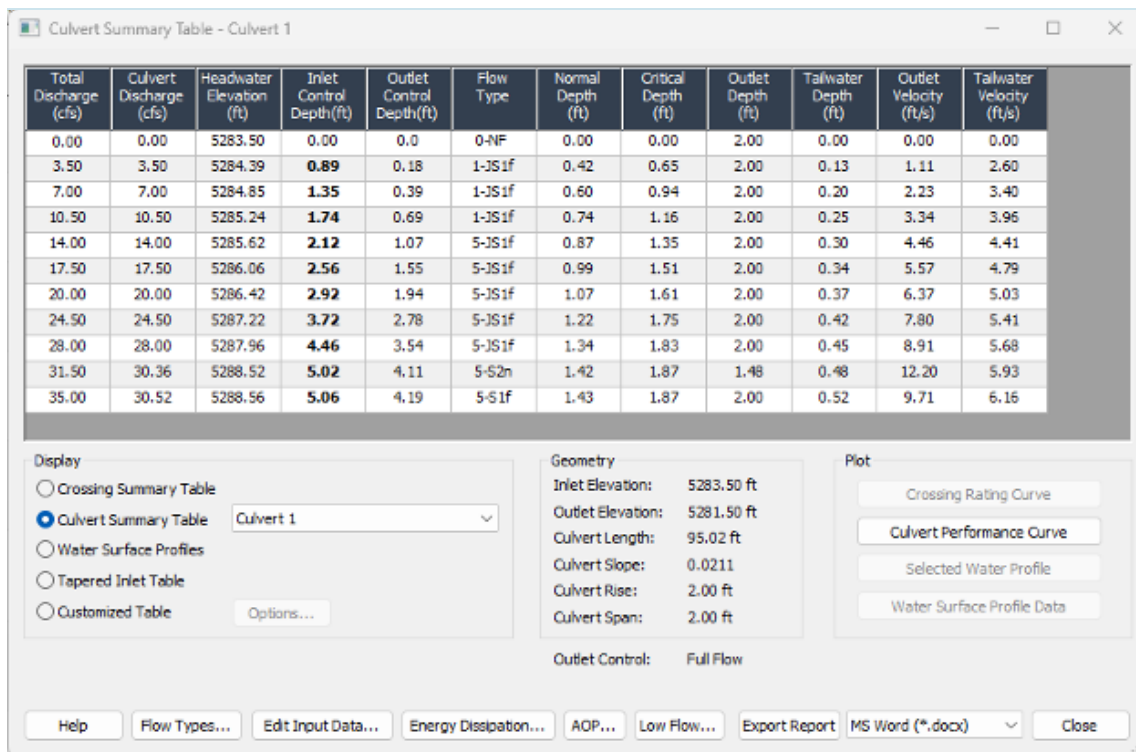


Figure 11-15. HY-8 output

# 9.0 CULVERT CHECKLIST

Criterion/Requirement	✓
Minimum culvert diameter of 15 inches.	
HW/D ratio does not exceed limits in Table 11-1, unless justified and adequate measures are implemented to protect embankment. Limit HW/D to 1.5 or less when possible.	
<p>Evaluate the need for safety grating for culverts:</p> <p>Follow criteria in Table 11-4 for circular culverts</p> <p>For box culverts, consider safety grates in cases where there is not a clear line of site from the entrance to the exit or when conditions within the culvert (bends, obstructions, vertical drops) or at the outlet are likely to trap or seriously injure a person.</p>	
Refer to the latest hydraulic design guidance from CDOT, FHWA, and AASHTO as appropriate for design.	
When a culvert is sized such that the overlying roadway overtops during large storms, check the depth of cross flow with the <i>Streets, Inlets, and Storm Drains</i> chapter.	
Provide adequate outlet protection in accordance with Section 6.0 of this chapter and the <i>Hydraulic Structures</i> chapter. Refer to the latest guidance in HEC-23 for additional information on countermeasures for scour.	

## 10.0 REFERENCES

- AECOM, 2024. Storm Drain Safety Grates: Computational Fluid Dynamics Modeling Report. Available at [www.mhfd.org](http://www.mhfd.org).
- American Iron and Steel Institute (AISI), 1980. Modern Sewer Design, Washington D.C.
- AASHTO, 2002. Standard Specifications for Highway Bridges, 17<sup>th</sup> Edition. AASHTO: Washington, D.C.
- AASHTO, 2007. Highway Drainage Guidelines. Chapter 7: Hydraulic Analysis for the Location and Design of Bridges. AASHTO: Washington, D.C.
- Annandale, G. W., 2006. Scour Technology: Mechanics and Engineering Practice. McGraw-Hill Civil Engineering Series.
- Caltrans, 2020. *Highway Design Manual, Seventh Edition, Chapter 810- Hydrology*. Sacramento, CA: California Department of Transportation
- CDOT, 2019. Drainage Design Manual. Denver, CO: Colorado Department of Transportation.
- CDOT, 2023. Structure Selection Report QA Checklist. <https://www.codot.gov/programs/bridge/bridge-manuals/form-letters/structure-selection-report-qa-checklist-final.pdf>
- CSU, 2024. Physical Model Flume Tests of Storm Drain Safety Grates. Available at [www.mhfd.org](http://www.mhfd.org)
- CWCB, 2008. Colorado Floodplain and Stormwater Criteria Manual. Denver, CO: Colorado Department of Natural Resources, Colorado Water Conservation Board.
- CWCB, 2024. Wildfire Ready Watersheds: Stream Crossing Assessment and Design Considerations for Post-Fire Conditions Fact Sheet. Denver, CO: Colorado Department of Natural Resources, Colorado Water Conservation Board. <https://www.wildfirereadywatersheds.com/resource>
- FHWA, 1993. Design of Bridge Deck Drainage, Hydraulic Engineering No. 21. Washington, DC: U.S. Department of Transportation, Federal Highway Administration.
- FHWA, 2001. Evaluating Scour at Bridges, Hydraulic Engineering Circular No. 18, Fourth Edition. Washington, DC: U.S. Department of Transportation, Federal Highway Administration.
- FHWA, 2005. Debris Control Structures Evaluation and Countermeasures. Hydraulic Engineering Circular No. 9. Publication No. FHWA-IF-04-016. Washington, DC: U.S. Department of Transportation, Federal Highway Administration.
- FHWA, 2006. Hydraulic Design of Energy Dissipators for Culverts and Channels. Hydrologic Engineering Circular No. 14, Third Edition. Washington, DC: U.S. Department of Transportation, Federal Highway Administration.
- FHWA, 2009. Bridge Scour and Stream Instability Countermeasures, Experience, Selection, and Design Guidance. Hydraulic Engineering Circular No. 23, Third Edition. Volumes 1 and 2. Washington, DC: U.S. Department of Transportation, Federal Highway Administration.
- FHWA, 2010. Culvert Design for Aquatic Organism Passage. Hydraulic Engineering Circular No. 16. Washington, DC: U.S. Department of Transportation, Federal Highway Administration.
- FHWA, 2012. Evaluating Scour at Bridges, Hydraulic Engineering Circular No. 18, Fifth Edition. Washington, DC: U.S. Department of Transportation, Federal Highway Administration.
- FHWA, 2012. Hydraulic Design of Safe Bridges, Hydraulic Design Series No. 7. Washington, DC: U.S. Department of Transportation, Federal Highway Administration.

- FHWA, 2012. Hydraulic Design of Highway Culverts, Hydraulic Design Series No. 5. Washington, DC: U.S. Department of Transportation, Federal Highway Administration.
- FHWA, 2012. Stream Stability at Highway Structures, Hydraulic Engineering Circular No. 20, Fourth Edition. Washington, DC: U.S. Department of Transportation, Federal Highway Administration.
- FHWA, 2016. Highways in the River Environment – Floodplains, Extreme Events, Risk and Resilience, Hydraulic Design Series No. 17. Washington, DC: U.S. Department of Transportation, Federal Highway Administration.
- FHWA, 2023. Highways in the River Environment: Roads, Rivers, and Floodplains, Hydraulic Design Series No. 16. Washington, DC: U.S. Department of Transportation, Federal Highway Administration.
- FHWA, 2023. Highway Hydrology: Evolving Methods, Tools, and Data, Hydrologic Engineering Circular No. 19. Publication No. FHWA-HIF-23-050. Washington, DC: U.S. Department of Transportation, Federal Highway Administration.
- FHWA, 2024. Aquatic Organism Passage at Highway Crossings: An Implementation Guide. FHWA Publication Number: HIF-24-054. Washington, DC: U.S. Department of Transportation, Federal Highway Administration.
- FHWA, 2024. HY 8 Culvert Hydraulic Analysis Program, Version 8.0.0. Washington, DC: U.S. Department of Transportation, Federal Highway Administration.
- Guo, J., Jones, J. and T.A. Earles, 2010. Method of Superimposition for Suction Force on Trash Rack. Journal of Irrigation and Drainage Engineering. J. Irrig. Drain. Eng. ASCE. 136. 10.1061/(ASCE)IR.1943-4774.0000253.
- Hipschman, R., 1970. Erosion Protection for the Outlets of Small and Medium Culverts. Electronic Theses and Dissertations. 3784. <https://openprairie.sdstate.edu/etd/3784>
- ICON Engineering, 2025. Geomorphically Informed Stream Crossing Structures. Available at [www.mhfd.org](http://www.mhfd.org)
- MHFD, 2024. Technical Memorandum on Safety Grates Recommendation for Circular Pipes. Available at [www.mhfd.org](http://www.mhfd.org)
- Propublica, 2021. Storm Drains Keep Swallowing People During Floods. Retrieved April 26, 2024 at <https://www.propublica.org/article/storm-drains-keep-swallowing-people-during-floods>.
- Union Pacific Engineering Department, March 26, 2019. General Conditions and Specifications.
- Union Pacific Railroad – BNSF Railway, January 5, 2016. Guidelines for Railroad Grade Separation Projects. Bridge Standards.
- U.S. Army Corps of Engineers, 2010. Hydrologic Engineering Center, River Analysis System (HEC-RAS) User’s Manual and Hydraulic Reference Manual.
- U.S. Fish and Wildlife Service, 2024. Culvert Design Guidelines for Ecological Function.
- Washington Department of Fish and Wildlife, 2003. Design of Road Culverts for Fish Passage.

DC: U.S. Department of Transportation, Federal Highway Administration.

Federal Highway Administration (FHWA). 2005a. Hydraulic Design of Highway Culverts, Hydraulic Design Series No. 5. Washington, DC: U.S. Department of Transportation, Federal Highway Administration.

Federal Highway Administration (FHWA). 2005b. Debris Control Structures Evaluation and Countermeasures. Hydraulic Engineering Circular No. 9. Publication No. FHWA-IF-04-016. September.

Federal Highway Administration (FHWA). 2011. HY 8 Culvert Hydraulic Analysis Program. Washington, DC: U.S. Department of Transportation, Federal Highway Administration.

SLA 1985. Design Manual for Engineering Analysis of Fluvial Systems. Prepared for the Arizona Department of Water Resources.

Peterka, A.J. 1984. Hydraulic Design of Stilling Basins and Energy Dissipators. Engineering Monograph No. 25. Washington, DC: U.S. Bureau of Reclamation.

Smith, C. D. 1975. Cobble Lined Structures. Canadian Journal of Civil Engineering, Volume 2.

Stevens, M.A., D.B. Simons, and F.J. Watts. 1971. Riprapped Basins for Culvert Outfalls. Highway Research Record No. 373. Washington, D.C.: Highway Research Service.

Stevens, M.A. and B.R. Urbonas. 1996. Design of Low Tailwater Riprap Basins for Storm Sewer Pipe Outlets. Flood Hazard News 26(1)11-14.

U.S. Army Corps of Engineers, 2010. Hydrologic Engineering Center, River Analysis System (HEC-RAS) Computer Program Version 4.1.0.

U.S. Army Corps of Engineers, 2010. Hydrologic Engineering Center, River Analysis System (HEC-RAS) User's Manual and Hydraulic Reference Manual



# Chapter 12

## Storage

### Contents

<b>1.0</b>	<b>Overview .....</b>	<b>1</b>
<b>2.0</b>	<b>Implementation of Regional, Sub-regional, and On-site Detention Facilities .....</b>	<b>2</b>
2.1	Regional Detention.....	2
2.2	Subregional Detention.....	5
2.3	Onsite Detention.....	6
2.4	Detention and UDFCD 100-Year Floodplain Management Policy.....	7
<b>3.0</b>	<b>Full Spectrum Detention as the Recommended Approach .....</b>	<b>8</b>
3.1	Background .....	8
3.2	Excess Urban Runoff Volume.....	9
3.3	Compatibility of Full Spectrum Detention with Minor and Major Event Detention.....	11
3.4	Water Quality Capture Volume and Full Spectrum Detention.....	12
<b>4.0</b>	<b>Sizing of Full Spectrum Detention Storage Volumes.....</b>	<b>17</b>
4.1	Simplified Equations .....	17
4.1.1	Full Spectrum Detention Volume .....	17
4.1.2	100-year Release Rates .....	19
4.1.3	Predevelopment Peak Discharges for Various Return Periods .....	20
4.2	UD-Detention Workbook.....	20
4.2.1	Hydrograph Routing using CUHP and SWMM.....	20
<b>5.0</b>	<b>Design Considerations .....</b>	<b>21</b>
5.1	General Layout and Grading .....	21
5.2	Storage Volume.....	22
5.3	Embankments.....	22
5.4	Emergency Spillways.....	23
5.4.1	Soil Riprap Spillway .....	23
5.4.2	Baffle Chute Spillway .....	24
5.5	Outlet Structure .....	25
5.5.1	Flush Safety Grate.....	26
5.6	Trash Racks and Debris Blockage.....	28
5.7	Inlets.....	29
5.8	Vegetation .....	29
5.9	Retaining Walls.....	29
5.10	Access .....	30
5.11	Geotechnical Considerations .....	30
5.12	Linings .....	30
5.13	Environmental Permitting and Other Considerations.....	30
5.14	Orifice and Weir Hydraulics .....	31
5.14.1	Orifices.....	31
5.14.2	Weirs.....	31
<b>6.0</b>	<b>Additional Configurations of Detention Facilities.....</b>	<b>34</b>
6.1	Water Storage Reservoirs.....	34
6.2	Upstream of Railroad and Highway Embankments .....	34

6.3	Side-Channel Detention Basins.....	34
6.4	Parking Lot Detention.....	34
6.5	Underground Detention.....	35
6.6	Blue Roofs .....	35
6.7	Retention Facilities .....	35
<b>7.0</b>	<b>Designing for Safety, Operation, and Maintenance.....</b>	<b>35</b>
<b>8.0</b>	<b>Design Examples .....</b>	<b>37</b>
8.1	Example - Design of a Full Spectrum Detention Sand Filter Basin using UD-Detention.....	37
<b>9.0</b>	<b>References.....</b>	<b>41</b>

## Tables

Table 12-1.	Extended detention basin combined with full spectrum detention .....	12
Table 12-2.	Retention pond combined with full spectrum detention .....	13
Table 12-3.	Constructed wetland pond combined with full spectrum detention.....	13
Table 12-4.	Sand filter or bioretention facility combined with full spectrum detention .....	16
Table 12-5.	Applicability of full spectrum sizing methods based on watershed area .....	17
Table 12-6.	Coefficients for NRCS hydrologic soil group A.....	19
Table 12-7.	Coefficients for NRCS hydrologic soil group B.....	19
Table 12-8.	Coefficients for NRCS hydrologic soil group C.....	20

## Figures

Figure 12-1.	Example configuration for regional detention (Source: Arapahoe County).....	3
Figure 12-2.	Example configuration for subregional detention (Source: Arapahoe County) .....	5
Figure 12-3.	Example configuration for on-site detention (Source: Arapahoe County).....	6
Figure 12-4.	EURV is relatively constant for runoff producing storms.....	9
Figure 12-5.	Comparison of full spectrum detention and conventional practices for a sample watershed consisting of fifty 100-acre subwatersheds .....	11
Figure 12-6.	Extended detention basin combined with full spectrum detention .....	12
Figure 12-7.	Retention pond combined with full spectrum detention.....	13
Figure 12-8.	Constructed wetland pond combined with full Sspectrum detention .....	13
Figure 12-9.	Sand filter combined with full spectrum detention.....	14
Figure 12-10.	Sand filter and zone 2 combined with downstream zone 3 basin.....	14
Figure 12-11.	Stand-alone sand filter with downstream zone 2/zone 3 basin.....	15
Figure 12-12.	Bioretention combined with full spectrum detention (not ideal for vegetation).....	15
Figure 12-13.	Bioretention and zone 2 combined with downstream zone 3 basin.....	16
Figure 12-14.	Stand-alone bioretention with downstream zone 2/zone 3 basin.....	16
Figure 12-15.	Flush grate (sloping drop box shown) .....	26
Figure 12-16.	Grate with vertical openings (horizontal drop box shown) .....	26
Figure 12-17.	Grate with vertical opening (sloping drop box shown) .....	27
Figure 12-18.	Grate with offset vertical panels (horizontal drop box shown) .....	27
Figure 12-19.	Typical grate configurations for outlet structures.....	29
Figure 12-20.	Sloping broad-crest weir.....	32
Figure 12-21.	Embankment protection details and rock sizing chart (adapted from Arapahoe County)...	33

## 1.0 Overview

Detention storage facilities manage stormwater quantity by attenuating peak flows during flood events. Depending on the design, they can also enhance stormwater quality by incorporating design components to promote sedimentation, infiltration, and biological uptake. This chapter provides guidance for the analysis and design of storage facilities implemented independently or in combination with stormwater quality facilities. Specific design guidance for stormwater quality facilities (e.g., extended detention basins, wetland basins, sand filters, etc.) are in Volume 3 of the USDCM.

Other topics discussed in this chapter include:

- Regional, sub-regional, and onsite detention facilities,
- Full spectrum detention,
- Basin sizing methodology,
- Outlet structures and safety grates,
- Emergency spillways,
- Landscape considerations,
- Designing for maintenance; and
- Parking lot detention.

UDFCD strongly encourages the development of multipurpose, attractive detention facilities that are safe, maintainable and viewed as community assets rather than liabilities.



**Photograph 12-1.** Detention facilities can be designed to integrate the management of both stormwater quality and quantity.



**Photograph 12-2.** Detention facilities can become attractive amenities and have potential to increase property values in commercial and residential settings, especially with the assistance of experienced landscape architects.

## **2.0 Implementation of Regional, Sub-regional, and On-site Detention Facilities**

Colorado law requires detention be provided to control the 100-year peak flow for all new development in the unincorporated portions of all counties, and most incorporated municipalities in Colorado require the same. There are three basic approaches for locating storage facilities in relation to their upstream watersheds. These are:

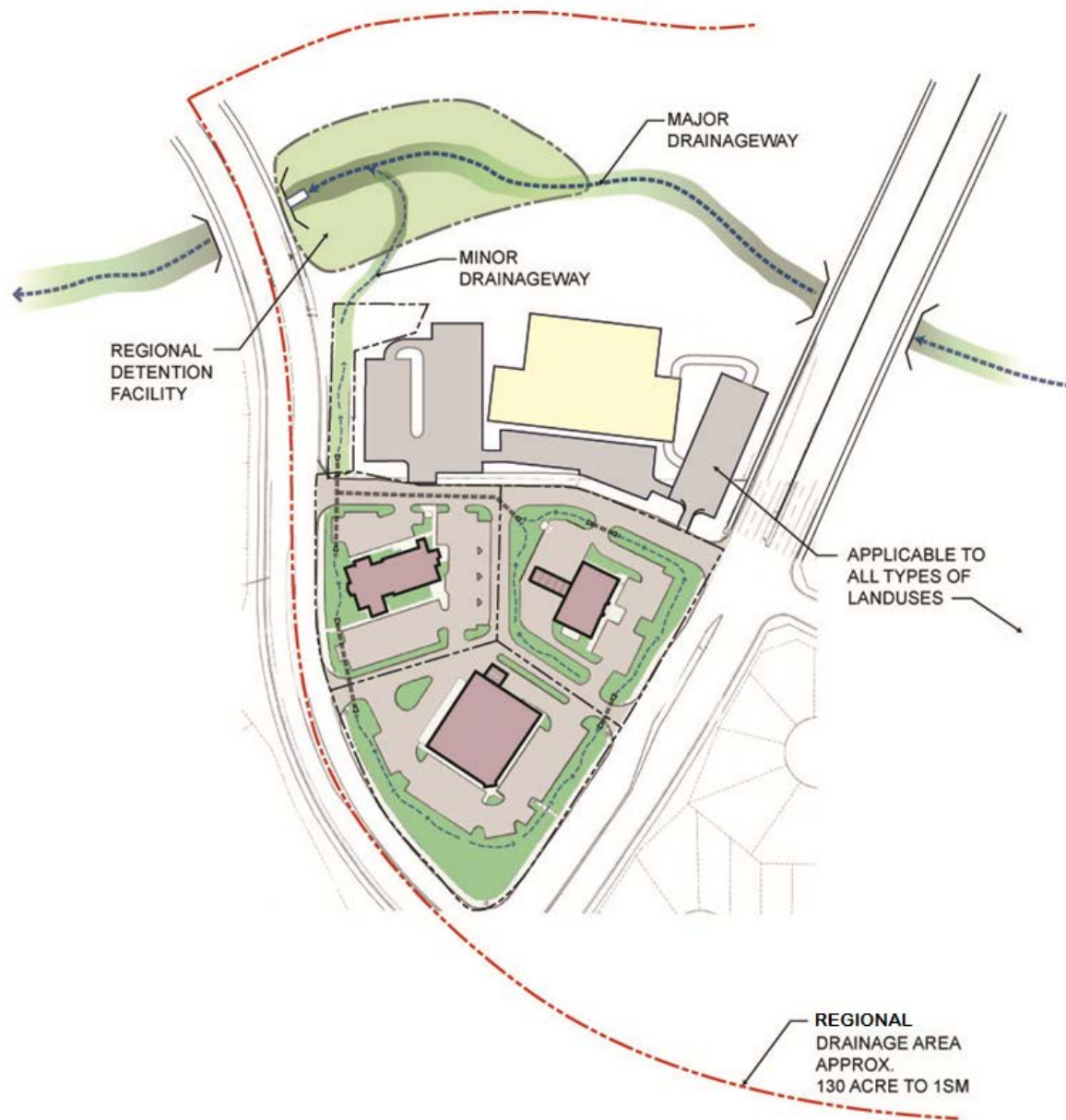
- Regional Detention
- Subregional Detention
- Onsite Detention

These three approaches are described in the following sections.

### **2.1 Regional Detention**

Regional detention basins serve multiple property owners in watershed areas ranging from about 130 acres to one square mile. Figure 12-1 provides an example configuration for an on-line regional detention approach.

In some cases, regional detention is effective for watershed areas larger than one square mile and for multiple facilities arranged in series; however, due to the complexities associated with how they function within a watershed, these configurations must be modeled and approved in the context of a formal master planning process.



**Figure 12-1. Example configuration for regional detention** (Source: Arapahoe County)

Regional detention facilities may be constructed by a public entity such as a municipality, special district, or property owner but should always be based on a master plan or a detailed hydrologic model approved by the local jurisdiction that accounts for future development upstream and impacts downstream of the facility.

Compared to on-site facilities, regional detention facilities typically require proportionally less total land area and are more cost effective to construct and maintain. Well-designed regional facilities may also provide more favorable riparian habitat and offer greater opportunities for achieving multi-use objectives, such as combining with park and open space resources and connecting shared use paths.

There are limitations associated with the implementation of on-line regional detention facilities. To avoid excessive accumulation of sediment, it is not recommended that regional detention facilities be constructed on streams experiencing significant upstream bed or bank erosion unless stabilization improvements are constructed ahead of the basin.

When an on-line regional facility is designed to provide water quality, storm water best management practices (BMPs) are still required in the tributary watershed to address water quality and channel stability for the reach upstream of the regional facility. In accordance with MS4 permits and regulations, areas of "New Development and Significant Redevelopment" must be treated with BMPs prior to discharging to a State Water. See Chapter 1 of Volume 3 of the USDCM for additional information when incorporating water quality into a regional facility.

## 2.2 Subregional Detention

Subregional detention generally refers to facilities that serve multiple landowners or lots and have a total watershed of less than 130 acres. Figure 12-2 illustrates a typical sub-regional detention approach in a commercial area. Most detention facilities located within residential communities are subregional in that they serve multiple lots that are each individually owned. Subregional detention facilities are located off-line from the receiving stream.

Like regional facilities, subregional detention facilities may be constructed by a public entity such as a municipality or special district to serve several landowners in the upstream drainage area, but are more typically designed and constructed by a single developer to serve an area being developed.

Subregional detention offers many of the same benefits as regional facilities in comparison to onsite detention, and is also subject to the same limitations, described in Section 2.1.

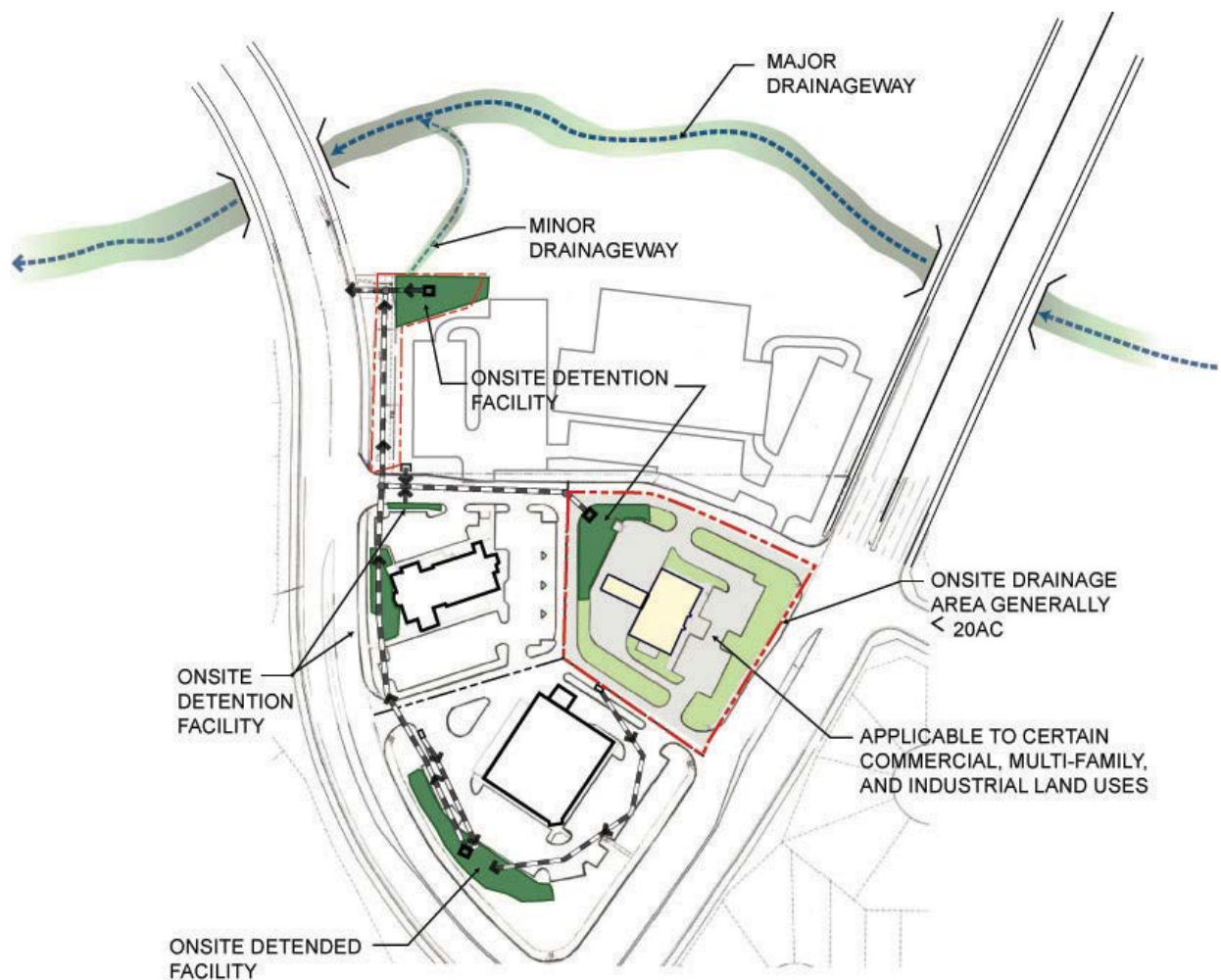


**Figure 12-2. Example configuration for subregional detention** (Source: Arapahoe County)

### 2.3 Onsite Detention

Onsite detention refers to facilities serving one lot, generally commercial or industrial sites draining areas less than 20 to 30 acres. Figure 12-3 illustrates a typical on-site detention approach.

On-site facilities are usually designed to control runoff from a specific land development site and are not typically located or designed to effectively reduce downstream flood peaks along the receiving stream. The volume of runoff detained in the individual on-site facility is relatively small and, their effectiveness in aggregate has been shown to diminish along the downstream reaches of streams. The application of consistent design and implementation criteria and assurance of their continued maintenance and existence is of paramount importance if large numbers of on-site detention facilities are to be effective in controlling peak flow rates on a watershed scale (Glidden 1981; Urbonas and Glidden 1983).



**Figure 12-3. Example configuration for on-site detention** (Source: Arapahoe County)

The principal advantage of on-site facilities is that developers can be required to build them as a condition of site approval. Major disadvantages include the need for a larger total land area for multiple smaller on-site facilities as compared to a larger regional facility serving the same tributary catchment area. If the individual on-site facilities are not properly maintained, they can become a nuisance to the community and a basis for many complaints to municipal officials. It is also difficult to ensure adequate maintenance and long-term performance. Approximately 100 on-site facilities built, or required by municipalities to be built, as a part of land developments over about a 10-year period were inspected and it was concluded that a lack of adequate maintenance and implementation contributed to a loss of continued function or even presence of these facilities (Prommesberger 1984).

## **2.4 Detention and UDFCD 100-Year Floodplain Management Policy**

In light of the difficulties involved in ensuring the long term effectiveness of on-site detention and privately maintained subregional detention facilities, UDFCD adheres to the following policies when developing hydrology for the delineation and regulation of the 100-year flood hazard zones:

1. Hydrology must be based on fully developed watershed conditions (e.g., imperviousness) as estimated to occur, at a minimum, over the next 50 years.
2. No detention basin will be recognized in the development of hydrology unless:
  - a. It serves a watershed that is at least 130 acres or otherwise provides substantial flood reduction, and
  - b. It is owned (or controlled by legal document) and maintenance is either performed or required by a public agency, and
  - c. The public agency has committed to ensure that the detention facility continues to operate in perpetuity as designed.

These policies are for the definition and administration of the 100-year floodplain and floodway zones and the design of facilities along major drainageways. The intent is not to discourage communities from using subregional or onsite detention discussed above. Subregional and onsite detention can be very beneficial for stormwater quality and quantity management, reducing the sizes of local storm drains and other conveyances, and providing a liability shield (defense) when needing to address the issue of keeping stormwater-related damages to downstream properties from increasing as upstream lands are developed.

## 3.0 Full Spectrum Detention as the Recommended Approach

The design guidance provided in this chapter is based on an approach termed “full spectrum detention.” The intent of full spectrum detention is to reduce the flooding and stream degradation impacts associated with urban development by controlling peak flows in the stream for a range of events.

### 3.1 Background

Roofs, streets, parking lots, sidewalks, and other impervious surfaces increase peak flows, frequency of runoff and total volume of stormwater surface runoff when compared to pre-development conditions.

This increase is most pronounced for the smaller, more frequent storms and can result in stream degradation and water quality impacts as well as flooding during the large events.

Criteria for stormwater detention design have evolved from a focus on the minor and major events to an approach shown to better control peak flows for a wide range of events. In the interest of stream stability, specific focus should be placed on frequent events. Incorporating a slow release for the water quality capture volume (WQCV) helps to address very frequent urban runoff events; however, it is also important to extend the volume of water attenuated to capture the range of flows that transport the most bed load in the receiving stream. This range of flows depends on reach-specific characteristics but is typically between the annual event and the 5-year peak flow rate. Runoff events in this range can produce profound geomorphic changes in ephemeral, intermittent and perennial streams resulting in severe erosion, loss of riparian habitat, and water quality degradation.

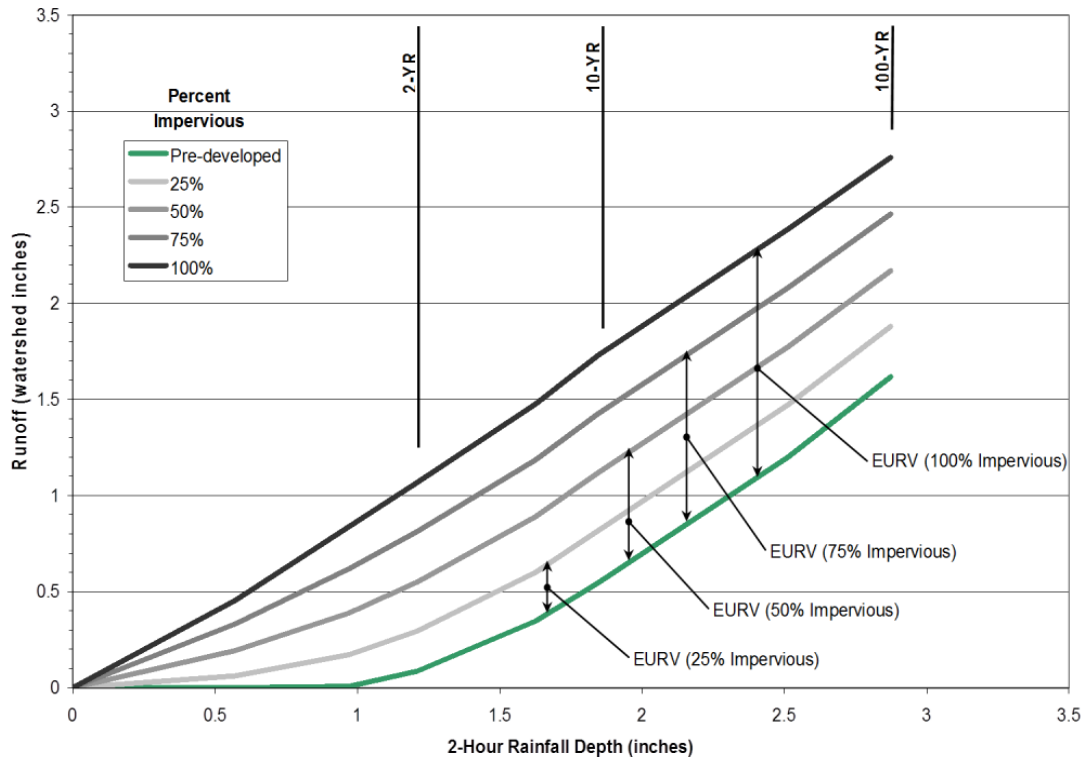
Furthermore, outflow hydrographs from traditional detention facilities tend to be “flat-topped” and broad, maintaining flows near the maximum release rates for relatively long periods of time. This allows hydrographs released from multiple independent basins to overlap and add to each other to a greater degree than they would have during pre-development conditions. Thus, traditional detention practices can result in an increase in *watershed-wide* discharges even if individual detention facilities each would control peak discharges to pre-developed conditions.

Full spectrum detention is designed to address these two limitations of traditional detention. First, it is focused on controlling peak discharges over the full spectrum of runoff events from small, frequent storms up to the 100-year flood. Second, full spectrum detention facilities produce outflow hydrographs that, other than a small release rate of the excess urban runoff volume (EURV), replicates the shape of pre-development hydrographs. Full spectrum detention modeling shows reduction of urban runoff peaks to levels similar to pre-development conditions over an entire watershed, even with multiple independent detention facilities.

### 3.2 Excess Urban Runoff Volume

The lower portion of volume in a full spectrum detention facility is designed to capture and slowly release the excess urban runoff volume (EURV). The EURV is the difference between the developed condition runoff volume and the pre-development volume. Based on the hydrologic methods used within the UDFCD region, the EURV appears to be relatively consistent at any given level of imperviousness for the range of storms (generally beyond the 2-year event) that produce runoff. This is illustrated in Figure 12-4. The full spectrum detention concept is to reduce runoff for all the frequent storms (smaller than approximately the 2-year event) to as close to zero as possible and less than the threshold value for erosion in most streams. When this is done, the remaining runoff from a site approximates the runoff volume for pre-development conditions.

The EURV is typically two to three times the water quality capture volume (WQCV) and the release rates are generally comparable. Therefore, designing for EURV typically results in a design that also meets the recommended drain time for treatment of the WQCV.



**Figure 12-4. EURV is relatively constant for runoff producing storms**

The upper portion of volume in a full spectrum detention facility is designed to reduce the developed condition 100-year peak discharge down to 90 percent of the pre-development 100-year peak flow rate from the tributary sub-watershed. Through modeling, it has been found that releasing 90 percent of the 100-year event peak discharge at each full spectrum detention basin within a watershed results in flows in the receiving stream that are near pre-development. Figure 12-5 illustrates the effectiveness of full spectrum detention in comparison to traditional practices for a test watershed made up of fifty 100-acre subwatersheds each modeled with a detention basin (Wulliman and Urbonas, 2005).

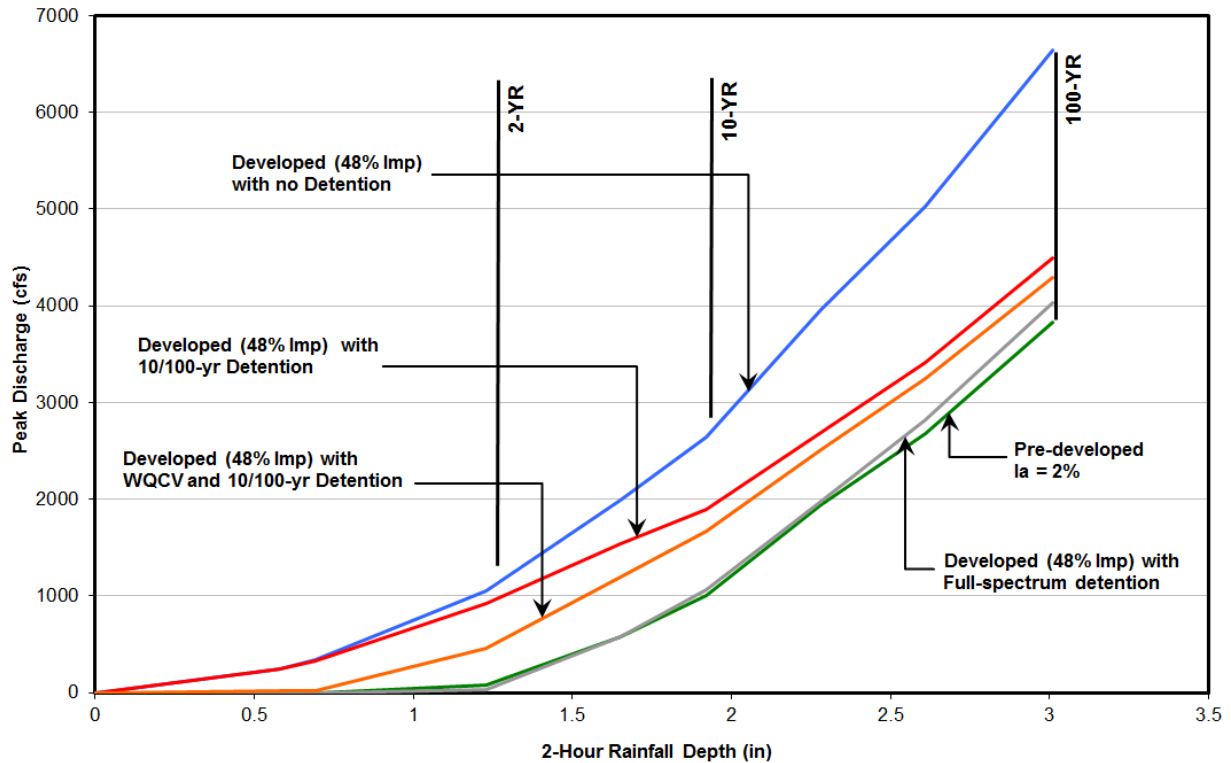
#### **Benefits of Implementing Full Spectrum Detention on a Watershed Level**

- A properly designed full spectrum detention facility can reduce urban peak discharges to levels similar to pre-development conditions for the full spectrum of runoff events from small, frequent storms up to the 100-year event. This reduces the stresses imposed by urban runoff on streams so degradation will occur at reduced rates compared to conventional detention practices.
- With the capture and slow release of the EURV mitigating to some degree the additional runoff impacts associated with development, the remaining volume that is released from a full spectrum facility approximates the runoff from the upstream area for pre-development conditions. This allows regional full spectrum detention to effectively control peak discharges within a watershed even when multiple independent facilities are used.
- The design of full spectrum detention is relatively simple, and certainly no more complex than traditional detention practices.
- Required 100-year storage volumes for full spectrum detention facilities are generally similar to traditional flood control and water quality detention practices.

Because of these benefits, UDFCD recommends the use of full spectrum detention over typical detention criteria associated with stormwater quantity.

### 3.3 Compatibility of Full Spectrum Detention with Minor and Major Event Detention

The EURV and 100-year detention volumes are similar in magnitude to 10-year/100-year detention facilities volumes. The main difference is that the EURV described in Section 2.2 is drained at a much slower rate than the 10-year detention volume would be based on past criteria provided in this manual.



**Figure 12-5. Comparison of full spectrum detention and conventional practices for a sample watershed consisting of fifty 100-acre subwatersheds**

Where existing master plans recommend detention facilities designed to address minor and major events, UDFCD generally intends that these will be implemented as full spectrum facilities; however, the final determination of detention policy should be made by each jurisdiction.

There may be opportunities to convert existing 10-year/100-year detention facilities into full spectrum facilities by reducing the capacity of the 10-year control orifice to a EURV release rate, and ensuring that the debris grate for the EURV orifices and the 100-year outlet and emergency spillway for the facility are adequate.

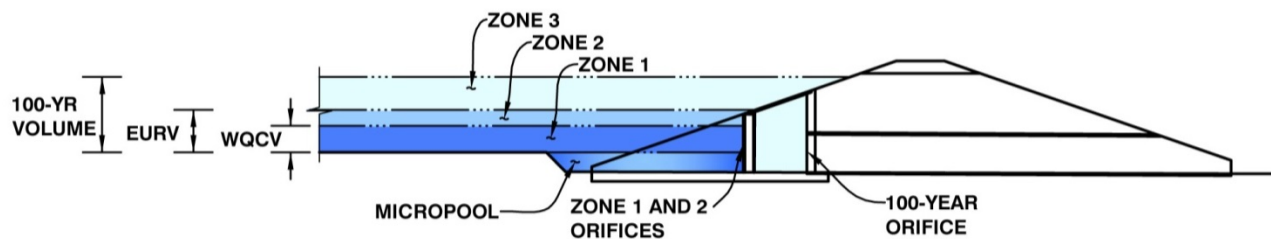
### 3.4 Water Quality Capture Volume and Full Spectrum Detention

This section provides criteria for incorporating five types of WQCV treatment best management practices (BMPs) into full spectrum detention basins. Volume 3 of the USDCM further describes these BMPs. They are:

- Extended detention basins,
- Retention ponds,
- Constructed wetland ponds,
- Sand filters, and
- Rain gardens (bioretention)

The 100-year full spectrum detention volume described in this chapter is consistently expressed as the total detention volume including EURV; also, EURV consistently includes the water quality volume. Therefore, the WQCV and the EURV are both inclusive of the 100-year full spectrum detention volume and UDFCD does not recommend adding any part of the WQCV to either the EURV or the 100-year volumes calculated based on Section 3.0.

Figure 12-6 illustrates an extended detention basin combined with full spectrum detention. In the figure, Zone 1 represents the water quality portion of the facility. Zone 2 represents the difference between the EURV and Zone 1. Zone 3 represents the difference between the 100-year volume and the EURV. The design volume, drain time, and release rate of each zone of an extended detention basin combined with full spectrum detention is shown in Table 12-1.



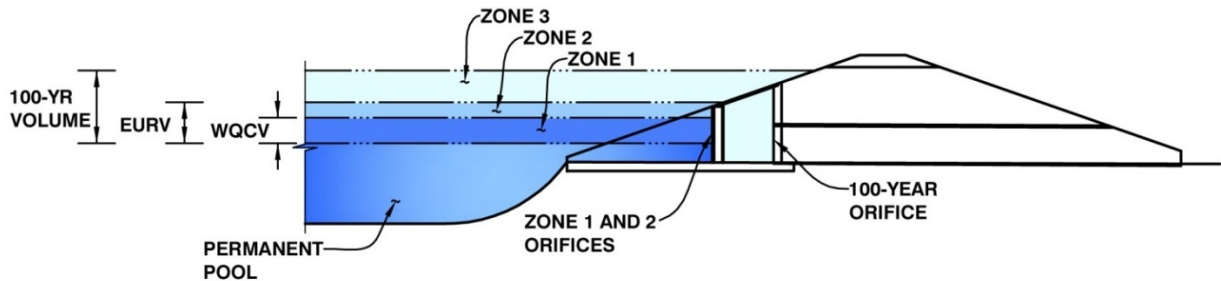
**Figure 12-6. Extended detention basin combined with full spectrum detention**

**Table 12-1. Extended detention basin combined with full spectrum detention**

Zone	Volume	Drain Time of Zone, hrs	Maximum Release Rate
1	40-hr WQCV	40	Based on drain time
2	EURV minus (40-hr WQCV))	12 to 32 <sup>1</sup>	Based on drain time
3	100-yr minus EURV	Based on release rate	0.9(predevelopment Q <sub>100</sub> )

<sup>1</sup>Colorado law requires 97% of the 5-year event to drain within 72 hours.

Because each of the five WQCV treatment BMPs has slightly different sizing criteria and release rate criteria, as described in Volume 3 of the USDCM, the design of full spectrum detention facilities also varies based on type of WQCV BMP. The design of a retention pond combined with full spectrum detention is shown in Figure 12-7 and in Table 12-2.



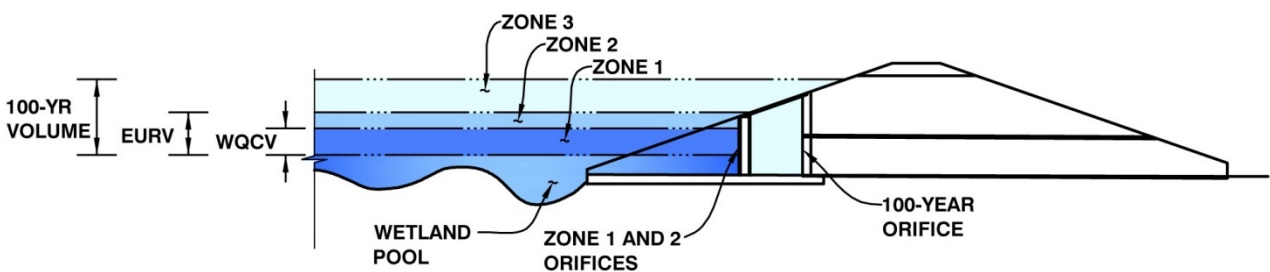
**Figure 12-7. Retention pond combined with full spectrum detention**

**Table 12-2. Retention pond combined with full spectrum detention**

Zone	Volume	Drain Time of Zone, hrs	Maximum Release Rate
1	12-hr WQCV	12	Based on drain time
2	EURV minus 12-hr WQCV	12 to 60 <sup>1</sup>	Based on drain time
3	100-yr minus EURV	Based on release rate	0.9(predevelopment Q <sub>100</sub> )

<sup>1</sup>Colorado law requires 97% of the 5-year event to drain within 72 hours.

The design of a constructed wetland pond combined with full spectrum detention is shown in Figure 12-8 and in Table 12-3.



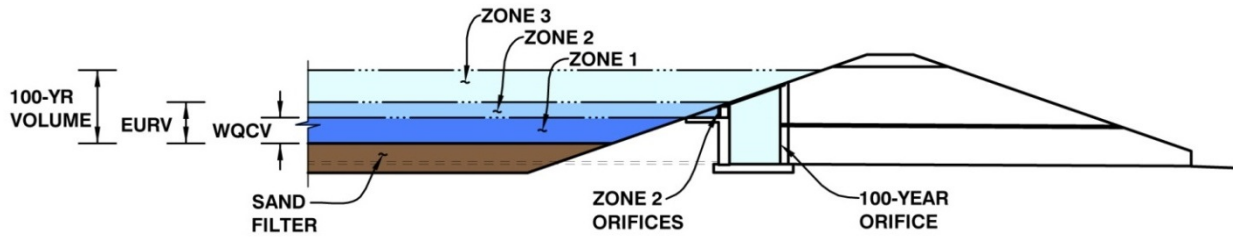
**Figure 12-8. Constructed wetland pond combined with full Spectrum detention**

**Table 12-3. Constructed wetland pond combined with full spectrum detention**

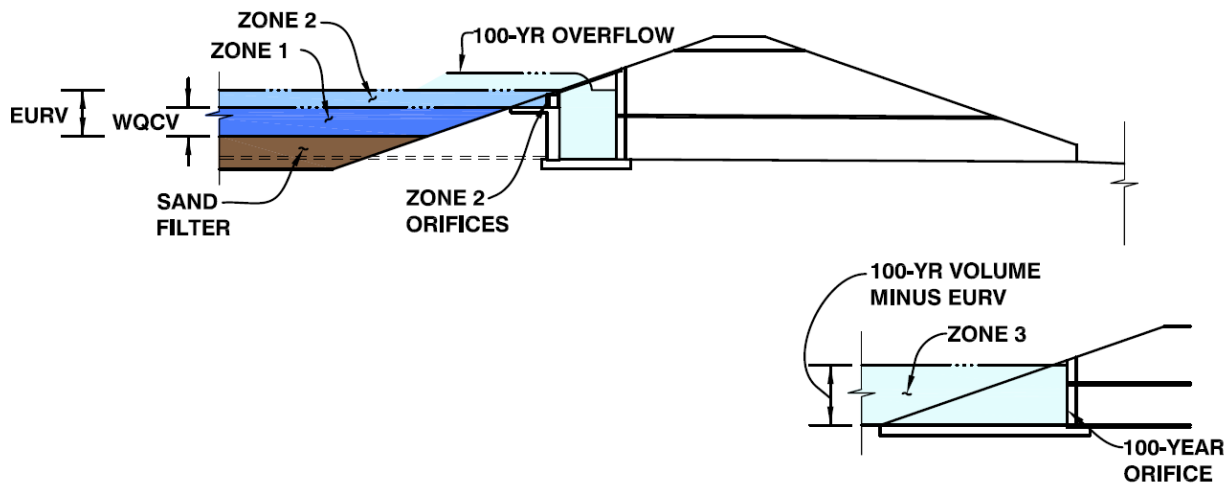
Zone	Volume	Drain Time of Zone, hrs	Maximum Release Rate
1	24-hr WQCV	24	Based on drain time
2	EURV minus 24-hr WQCV	12 to 48 <sup>1</sup>	Based on drain time
3	100-yr minus EURV	Based on release rate	0.9(predevelopment Q <sub>100</sub> )

<sup>1</sup>Colorado law requires 97% of the 5-year event to drain within 72 hours.

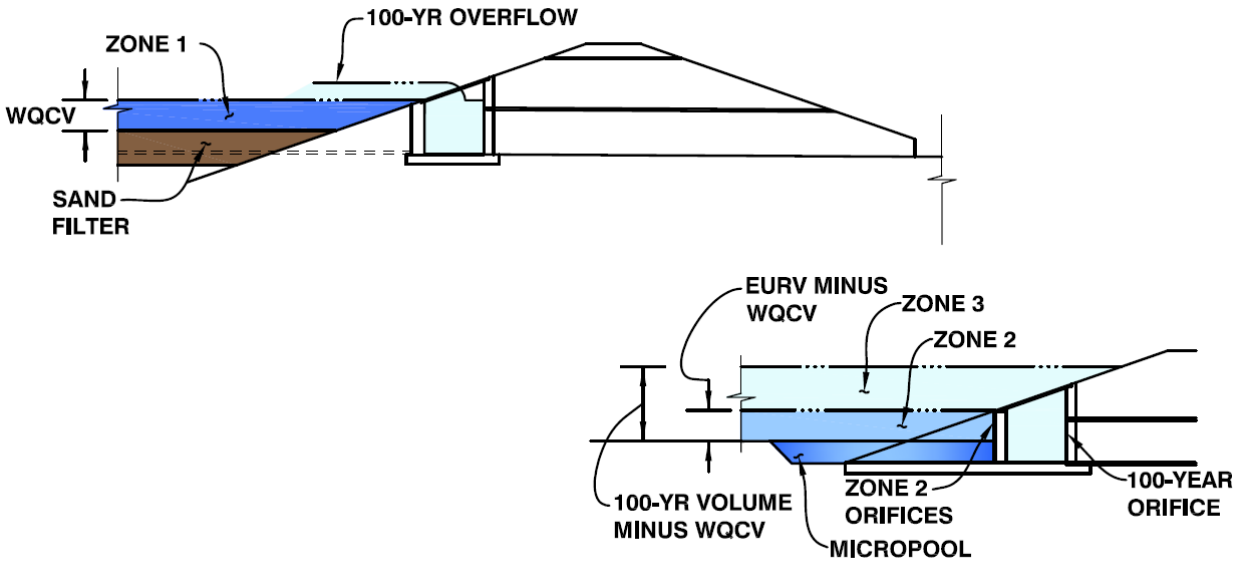
The design of a sand filter combined with full spectrum detention is shown in Figure 12-9 and in Table 12-4. Although the water quality event is released through the filter media, it is recommended that an orifice be provided to drain Zone 2 (the balance of the EURV) and a grated inlet or spillway be used to control the release of Zone 3 (the balance of the 100-year volume). This configuration reduces the amount of Zone 2 and 3 runoff flowing through the filter media.



**Figure 12-9. Sand filter combined with full spectrum detention**

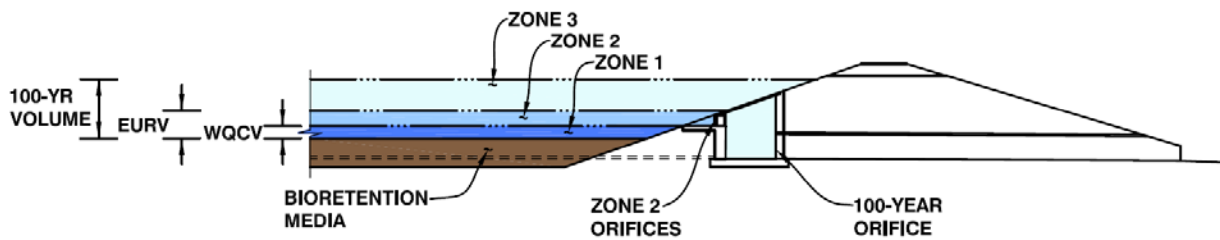


**Figure 12-10. Sand filter and zone 2 combined with downstream zone 3 basin**



**Figure 12-11. Stand-alone sand filter with downstream zone 2/zone 3 basin**

The design of a bioretention facility combined with full spectrum detention is shown in Figure 12-12 and in Table 12-4. As in a sand filter, it is recommended that an orifice plate be provided to drain Zone 2 (the balance of the EURV) and a grated inlet or spillway be used to control the release of Zone 3 (the balance of the 100-year volume). Because these facilities are often implemented in compact areas and in multiple installations such as in parking medians and small landscaped areas, and because maintaining vegetation is critical to the facility, it is recommended to separate these facilities from Zone 3 or from both Zone 2 and 3. Configurations of separate facilities are shown in Figures 12-13 and 12-14. In these cases, the volume, drain time, and release rate of the zones are still determined based on Table 12-4.



**Figure 12-12. Bioretention combined with full spectrum detention (not ideal for vegetation)**

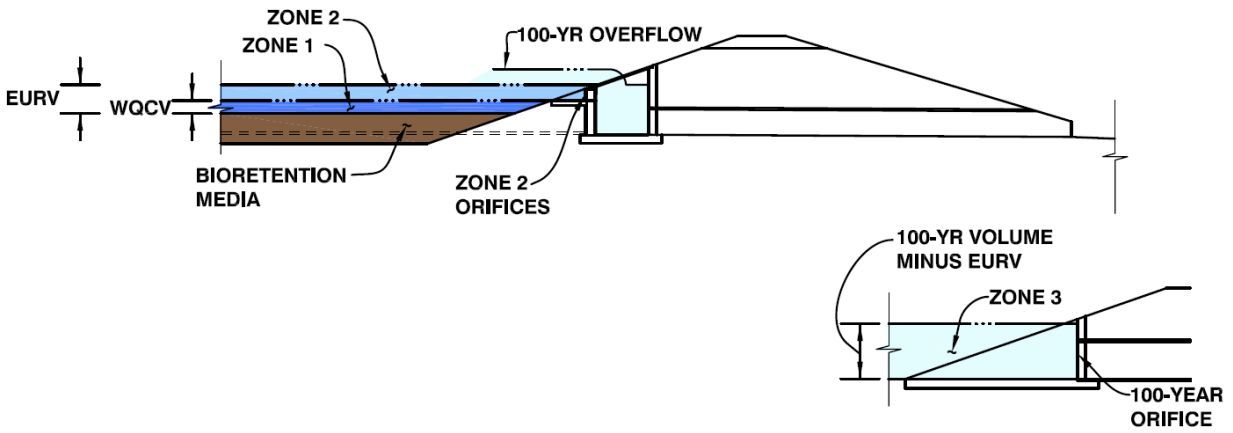


Figure 12-13. Bioretention and zone 2 combined with downstream zone 3 basin

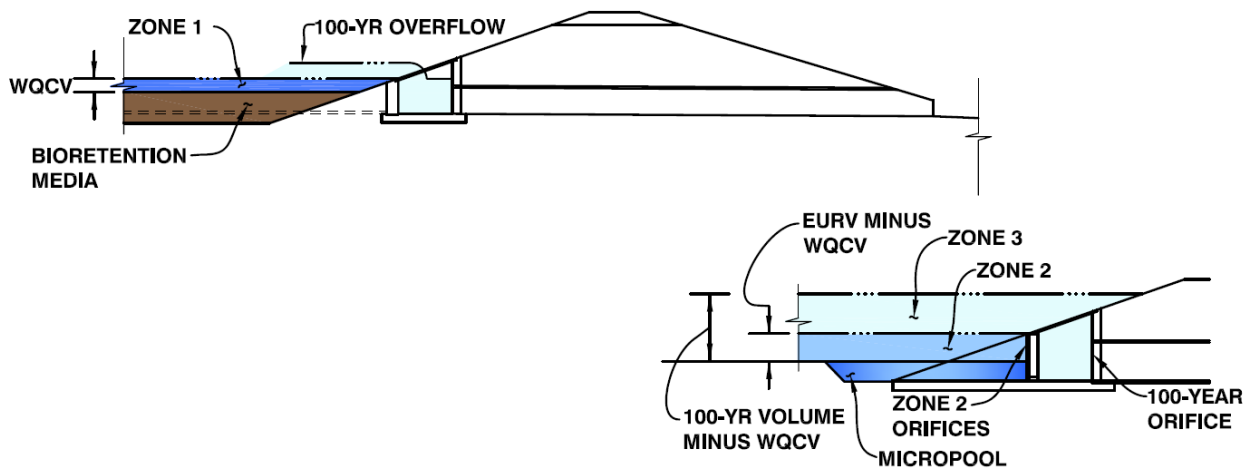


Figure 12-14. Stand-alone bioretention with downstream zone 2/zone 3 basin

Table 12-4. Sand filter or bioretention facility combined with full spectrum detention

Zone	Volume	Drain Time of Zone, hrs	Maximum Release Rate
1	12-hr WQCV	12	Based on drain time
2	EURV minus 12-hr WQCV	12 to 32 <sup>1</sup>	Based on drain time
3	100-yr minus EURV	Based on release rate	0.9(predevelopment Q <sub>100</sub> )

<sup>1</sup>Colorado law requires 97% of the 5-year event to drain within 72 hours.

## 4.0 Sizing of Full Spectrum Detention Storage Volumes

Three methods for sizing full spectrum detention storage volumes are described in the USDCM, as follows:

1. Simplified Equation
2. UD-Detention workbook
3. Hydrograph routing using CUHP and SWMM

The recommended range of application for the methods based on upstream watershed area is shown in Table 12-5. Full spectrum detention facilities may be sized using any of the methods shown in the table for the ranges of watershed area; however, the UD-Detention workbook more accurately represents input variables than the simplified equation and the hydrograph approach provides the most accurate approach. UDFCD recommends the hydrograph routing approach when evaluating multiple full spectrum detention facilities arranged in parallel or series in a watershed. The three sizing methods are described in the following sections.

**Table 12-5. Applicability of full spectrum sizing methods based on watershed area**

Watershed Properties	Sizing Method		
	Simplified Equations	UD-Detention <sup>1</sup>	CUHP/SWMM Hydrograph Routing
Less than 10 acre	X	X	
10 to 50 acres		X	X
50 to 130 acres		X	X
130 acres to 1 mile <sup>2</sup>		X	X
Greater than 1 mile <sup>2</sup>		X	X
Multiple detention facilities in parallel or series			X

<sup>1</sup>See Section 4.2 for additional discussion on the use of UD-Detention for the preliminary design and final design of a full spectrum facility.

### 4.1 Simplified Equations

Simplified equations are provided in this section for determining full spectrum detention design volumes and 100-year release rates. Once these values are determined, a full spectrum detention facility may be designed according to the technical guidance described in Section 5.0.

#### 4.1.1 Full Spectrum Detention Volume

Three different volumes are associated with the design of a full spectrum detention facility, as illustrated in Section 3.4. These are:

1. **WQCV** (Zone 1)
2. **EURV** (Zone 1 plus Zone 2)
3. **100-year volume** (sum of Zones 1, 2, and 3)

Within the ranges identified in Table 12-5, these volumes may be determined using simplified equations, as described below.

**WQCV.** The water quality capture volume for each of the five types of water quality facilities shown in Section 3.4 can be calculated based on the procedures described in Volume 3 of the USDCM.

**EURV.** Use equations 12-1, 2 and 3 to find EURV in watershed inches for specific soil types.

$$\text{EURV}_A = 1.68i^{1.28} \quad \text{Equation 12-1}$$

$$\text{EURV}_B = 1.36i^{1.08} \quad \text{Equation 12-2}$$

$$\text{EURV}_{CD} = 1.20i^{1.08} \quad \text{Equation 12-3}$$

Where:

$\text{EURV}_K$  = Excess urban runoff volume in watershed inches ( $K$  indicates NRCS soils type),  
 $i$  = Imperviousness ratio (a decimal less than or equal to 1)

The Technical Memorandum entitled *Determination of the EURV for Full Spectrum Detention Design*, dated December 22, 2016 documents the derivation of these equations. This is available at [www.udfcd.org](http://www.udfcd.org). Apply the equations above for each of the soil types found in the watershed and then calculate a weighted average value based on the relative area proportion of each soil type. Convert the EURV in watershed inches to a volume multiplying it by the watershed area.

Whenever NRCS soil surveys are not available for a catchment area, soils investigations are recommended to estimate equivalent soil type.

**100-Year Volume.** A simplified equation can be used to determine the required 100-year full spectrum detention volume for tributary areas less than 10 acres. This volume includes the EURV (and the EURV includes the WQCV). UDFCD does not recommend adding additional volume above that provided in Equation 12-4. The derivation of this equation is documented in a Technical Memorandum entitled *Estimation of Runoff and Storage Volumes for Use with Full Spectrum Detention*, dated January 5, 2017 (available at [www.udfcd.org](http://www.udfcd.org)). If a more detailed analysis is desired, see Table 12-5. The 100-year volume in watershed inches is converted to cubic feet or acre-feet by multiplying by watershed area and converting units.

$$V_{100} = P_1 \left[ \begin{array}{l} (0.806i^{1.225} + 0.109i^{0.225})A\% + (0.412i^{1.371} + 0.371i^{0.371})B\% \\ + (0.341i^{1.389} + 0.398i^{0.389})CD\% \end{array} \right] \quad \text{Equation 12-4}$$

Where:

$V_{100}$  = detention volume in watershed inches

$P_1$  = one-hour rainfall depth (inches)

$i$  = imperviousness ratio (a decimal less than or equal to 1)

$A\%$ ,  $B\%$ , and  $CD\%$  = indicates percentage of each NRCS soils type (expressed as a decimal)

### 4.1.2 100-year Release Rates

The maximum allowable 100-year release rate for a full spectrum detention facility is equal to 90 percent of the predevelopment discharge for the upstream watershed. Modeling has shown that using this release rate for multiple full spectrum detention basins within a watershed is effective in controlling future development peak discharges in the receiving stream to levels below predevelopment conditions for the 2, 5, 10, 25, 50, and 100-year events.

The predevelopment 100-year unit discharge for specific soil types per acre of tributary catchment varies based on the watershed slope and the watershed shape (described as the ratio of the flow length squared to the watershed area). Use Equation 12-5 with coefficients provided in Tables 12-6, 12-7, and 12-8 to calculate the peak unit flow rate based on an assumed predevelopment imperviousness of 2%. When using this equation, UDFCD recommends a sloped value no less than 0.01 and no greater than 0.04 and a shape value no less than one and no greater than six. Multiply the 100-year peak unit flow rate by 0.9 to determine the allowable 100-year release from a watershed.

See the Technical Memorandum entitled *UDFCD Predeveloped Peak Unit Flowrates*, dated December 21, 2016 for documentation of the following equation and tables. This is available at [www.udfcd.org](http://www.udfcd.org).

$$q = P_1 C_1 S^{C_2} \left( \frac{L^2}{A} \right)^{C_3} \quad \text{Equation 12-5}$$

Where:

- $q$  = peak unit flow rate (cfs/acre)
- $P$  = one-hour precipitation depth (in) from NOAA Atlas 14
- $S$  = watershed flow path slope (ft/ft)
- $L$  = watershed flow path length (ft)
- $A$  = area of tributary (ft<sup>2</sup>)
- $C_1, C_2, C_3$  = coefficients dependent on event frequency (see Tables 12-6, 12-7, and 12-8)

**Table 12-6. Coefficients for NRCS hydrologic soil group A**

Return Period →		2-Year	5-Year	10-Year	25-Year	50-Year	100-Year	500-Year
Leading Coeff.	$C_1$	0.0014	0.0104	0.0208	0.0478	0.2652	0.5622	0.9318
Slope Exp.	$C_2$	0.1684	0.2065	0.2070	0.2491	0.2056	0.2021	0.1853
Shape Exp.	$C_3$	-0.3533	-0.4430	-0.4453	-0.4406	-0.4385	-0.4286	-0.3933

**Table 12-7. Coefficients for NRCS hydrologic soil group B**

Return Period →		2-Year	5-Year	10-Year	25-Year	50-Year	100-Year	500-Year
Leading Coeff.	$C_1$	0.0285	0.0377	0.3509	0.8566	1.0437	1.2088	1.4061
Slope Exp.	$C_2$	0.1911	0.1855	0.2069	0.1761	0.1743	0.1677	0.1640
Shape Exp.	$C_3$	-0.4045	-0.3950	-0.4446	-0.3729	-0.3696	-0.3542	-0.3470

**Table 12-8. Coefficients for NRCS hydrologic soil group C**

Return Period →		2-Year	5-Year	10-Year	25-Year	50-Year	100-Year	500-Year
Leading Coeff.	C <sub>1</sub>	0.0338	0.2418	0.5375	0.9920	1.1614	1.3053	1.4949
Slope Exp.	C <sub>2</sub>	0.1869	0.2005	0.1901	0.1720	0.1715	0.1651	0.1623
Shape Exp.	C <sub>3</sub>	-0.3946	-0.4280	-0.4055	-0.3641	-0.3637	-0.3490	-0.3438

When multiple soil types exist in the watershed, use the table values for each soil type and calculate a weighted average value relative to the area proportion of each soil type. Use Equation 12-6 to calculate the allowable discharge from the basin.

$$Q = 0.9aq \quad \text{Equation 12-6}$$

Where:

- $Q$  = Allowable 100-year release rate (cfs)
- $a$  = Area of watershed (acres)
- $q$  = weighted average unit release rate based on relative proportions of watershed soil types (cfs/acre)

Unless otherwise recommended in an approved master plan, the maximum releases rates described in this section are for all full spectrum detention facilities.

### 4.1.3 Predevelopment Peak Discharges for Various Return Periods

The intent of the UDFCD full spectrum detention policy is to manage developed condition peak flows to levels similar to predevelopment conditions for a full range of return periods in areas serviced by full spectrum detention facilities. To gain a sense for the magnitude of predevelopment peak flow rates for various return rates, see the Technical Memorandum entitled *UDFCD Predeveloped Peak Unit Flowrates*, (MacKenzie and Rapp, 2016). This is available at [www.udfcd.org](http://www.udfcd.org).

## 4.2 UD-Detention Workbook

Beyond the simplified equation described in Section 4.1, an Excel-based workbook is available to size full spectrum detention basins for the range of watershed sizes identified in Table 12-5. UD-Detention is available at [www.udfcd.org](http://www.udfcd.org). This workbook uses the Modified Puls reservoir routing method to evaluate performance of the facility based on tributary watershed parameters and variables associated with the basin/pond geometry and outlet configuration. It compares calculated release rates to predevelopment discharges for the 2, 5, 10, 25, 50, and 100-year events. UD-Detention allows analysis of any retention pond or detention basin including extended detention, bioretention, sand filters, basins that may or may not be full spectrum, basins that only include one or two controlled zones, or basins having unusual outlet structures.

Section 8.0 of this chapter includes an example problem using each of the workbooks.

### 4.2.1 Hydrograph Routing using CUHP and SWMM

Hydrograph routing using CUHP and SWMM is a third option for sizing and designing full spectrum detention facilities, based on the watershed properties identified in Table 12-5. This is the only method that is able to assess the performance of multiple detention facilities arranged in parallel or in series in a watershed. Hydrograph routing using SWMM is similar to the evaluation mode of UD-Detention in that

the user needs to input stage-area and stage-discharge information based on a preliminary design and iterations may be necessary to arrive at a final basin and outlet structure configuration that reduces developed condition peak flows to levels equal to or below predevelopment conditions.

The reservoir routing capabilities in SWMM determine a detention basin's outflow characteristics given the stage-discharge relationship for a reservoir outlet link and the stage- area relationship for the reservoir storage node of the model. The stage- area relationship is determined by finding the water surface areas of the basin at different depths or elevations, which are then used by the model to calculate the incremental volumes used as the stage rises and falls. The basin layout and outlet structure are modified as needed after each model run to adjust the corresponding stage-area and stage-discharge data pairs, until the outflow from the basin meets the specified flow limit. No description of the theory of reservoir routing is provided in the USDCM, as the subject is well described in many hydrology reference books (Viessman and Lewis 1996; Guo 1999b).

For full spectrum basins evaluated using hydrograph routing, the EURV portion of the basin still needs to be sized using Equations 12-1 through 12-3 in Section 4.1 and the outlet designed to empty this volume as described in Section 3.4. The 100-year peak flow control volume above the EURV (Zone 3) must be determined, and its outlet designed using full hydrograph routing protocols. The maximum allowable 100-year release rate should not exceed 90 percent of the approved predevelopment release rate determined through CUHP/SWMM modeling of the upstream watershed (this may vary slightly from the predevelopment discharge values presented in Section 4.1.2), or maximum flow rates recommended in an accepted master plan.

## 5.0 Design Considerations

The design of a detention facility entails detailed hydraulic, structural, geotechnical, and civil design. This includes a detailed site grading plan, embankment design, spillway design, hydraulic and structural design of the outlet works, safety grate design, maintenance access, consideration of sedimentation and erosion potential within and downstream of the facility, liner design (if needed), etc. Collaboration between geotechnical engineers, structural engineers, hydrologic and hydraulic engineers, land planners, landscape architects, biologists, and/or other disciplines is encouraged during the preliminary and final design phases.

It is beyond the scope of the USDCM to provide detailed dam design guidance. There are many excellent references in this regard, such as *Design of Small Dams* (U.S. Bureau of Reclamation 1987). UDFCD urges all designers to review and adhere to the guidance in such references as failure of even small embankments can have serious consequences for the public and the municipalities downstream of the embankment.

As discussed in Section 3.4, full spectrum detention facilities are configured together with one of five types of water quality basins described in Volume 3 of the USDCM. The design of the water quality portion of the facility, illustrated as Zone 1 in Section 3.4, is described in detail in Volume 3. The following guidelines for the design of full spectrum detention facilities apply to Zones 2 and 3 as shown in Figures 12-6 through 12-14.

### 5.1 General Layout and Grading

Storage facility geometry and layout are often best developed in concert with land planners and landscape architect. Whenever desirable and feasible, multiple uses of a basin should be considered, such as creation of riparian and wetland vegetation, wildlife habitat, paths, and other passive or active recreation

opportunities. If multiple uses are being contemplated, it is recommended that the inundation of passive recreational areas be limited to one or two occurrences a year and of active recreation areas to once every two years. Generally, the area within Zone 1 and Zone 2 is not well suited for active recreation facilities such as ballparks, playing fields, and picnic areas, but may be suitable for passive recreation such as wildlife habitat and some hiking trails. It is desirable to shape the water quality portion of the facility (Zones 1 and 2) with a gradual expansion from the inlet and a gradual contraction toward the outlet, thereby minimizing short-circuiting.

Maintenance is also an important consideration with respect to layout and grading. Consider how lower areas of the basin, such as the forebay and micropool will be accessed, and with what equipment.

## 5.2 Storage Volume

Provide the total 100-year storage volume determined using one of the three methods described in Section 4, along with additional basin storage and depth necessary to contain emergency flows and provide freeboard as described in Section 5.3.

## 5.3 Embankments

Embankment should be designed to not catastrophically fail during the 100-year and larger storms that the facility may encounter. The following criteria apply in many situations (ASCE and WEF 1992):

- **Side Slopes:** For ease of maintenance, the side slopes of the embankment should not be steeper than 3(H):1(V), with 4(H):1(V) preferred. The embankment's side slopes should have fully vegetated coverage, with no trees or shrubs above the basin floor. Soil-riprap protection (or equivalent) may be necessary to protect it from wave action on the upstream face, especially in retention ponds.
- **Settlement and Compaction:** The design height of the embankment should be increased by roughly 5 percent to account for settlement. All earth fill should be free from unsuitable materials and all organic materials such as grass, turf, brush, roots, and other organic material subject to decomposition. The fill material in all earth dams and embankments should be compacted to at least 95 percent of the maximum density based on the Modified Proctor method of ASTM D698 testing.
- **Freeboard:** The elevation of the top of the embankment should be a minimum of 1 foot above the water surface elevation when the emergency spillway is conveying the maximum design or emergency flow. When the embankment is designed to withstand overtopping of the undetained peak flow without failure, freeboard requirements may be reduced or waived.

Anti-Seepage may also be required. This topic is covered in detail in FEMA's *Technical Manual: Conduits through Embankment Dams* (2005) and NRCS's *National Design Construction and Soil Mechanics Center Technical Note – Filter Diagrams for CO-1 Structures* (2003). Construction of a filter diaphragm will be adequate in most scenarios covered in this chapter.

If the storage facility is determined to be “jurisdictional” per the criteria of Colorado Division of Water Resources (DWR), also known as the Office of the State Engineer, the embankment shall be designed, constructed and maintained to meet DWR's most-current criteria for jurisdictional structures. The design for an embankment of a stormwater detention or retention storage facility should be based upon a site-specific engineering evaluation.

## 5.4 Emergency Spillways

Provide an open channel emergency spillway to convey flows that exceed the primary outlet capacity or when the outlet structure becomes blocked with debris. When the storage facility falls under the jurisdiction of the DWR, design this spillway based on the storm prescribed by the DWR (DWR 2007). If the storage facility is not a jurisdictional structure, the size of the spillway design storm should be based upon the risk and consequences of a facility failure (e.g., avoidance of a critical facility). Generally, embankments should be fortified against and/or have spillways that, at a minimum, are capable of conveying the 100-year peak runoff from the fully developed tributary area (prior to routing flows through the detention basin). However, detailed analysis and determination of downstream hazards (such as critical facilities) should be performed and may indicate that the embankment protection and/or spillway design needs to be designed for events larger than the 100-year design storm.

An emergency spillway also controls the location and direction of the overflow. Clearly depict the emergency spillway and the path of the emergency overflow downstream of the spillway and embankment on the construction plans and do not allow structures (such as utility boxes) to be placed in the path of the emergency spillway or overflow.

Soil riprap is the most common method for providing embankment protection on a spillway. Although not preferred, baffle chute spillways may also be considered on a case by case basis. Further discussion regarding these two types of embankment protection is provided below.

### 5.4.1 Soil Riprap Spillway

Soil riprap embankment protection should be sized based on methodologies developed specifically for overtopping embankments. Two such methods have been documented (U.S. Nuclear Regulatory Commission, 1988 and Robinson et al., 1998). See these publications for a complete description of sizing methodology and application information. Figure 12-21 illustrates typical rock sizing for small (under 10-foot high) embankments based on these procedures that may be used during preliminary design to get an approximate idea of rock size. Final design should be based on the more complete procedures documented in the referenced publications. The thickness should be based on the criteria identified in the *Open Channels* chapter for steep channels. For spillway design, it is critical that the soil riprap has an adequate percentage of well-graded rock.

The invert of the emergency spillway is set at or above the 100-year water surface elevation (based on local jurisdiction criteria). A concrete wall is recommended at the emergency spillway crest extending at least to the bottom of the soil riprap located immediately downstream. The top of the crest wall at the sides should extend to the top of the embankment, at least one foot above the spillway elevation.

### 5.4.2 Baffle Chute Spillway

The USBR has developed design standards for a reinforced concrete chute with baffle blocks on the sloping face of a spillway, commonly referred to as baffled chute drop spillway. The primary reference that is recommended for the design of these structures is *Design of Small Dams* (1987). In addition, *Design of Small Canal Structures* (Aisenbrey, et al. 1978) and *Hydraulic Design of Stilling Basins and Energy Dissipators* (Peterka 1984) may provide useful information for the design of baffle chute spillways.

The hydraulic concept behind baffle chute spillways involves flow repeatedly encountering obstructions (baffle blocks) that are of a nominal height equivalent to critical depth. The excess energy is dissipated through the drop by the momentum loss associated with reorientation of the flow. *Design of Small Dams* provides guidelines for sizing and spacing the blocks. Designing for proper approach velocities is critical to structure performance. One advantage of this type of spillway is that it does not require any specific tailwater depth. However, the designer does need to consider local flow and scour patterns in the transition back to the channel.



**Photograph 12-3.** Baffle chute drop after several decades of service.

For safety reasons and considerations of appearance, a baffle chute spillway is not recommended for use as a grade control structure in a stream. Caution is advised when using a baffle chute spillway in a high debris area because the baffles can become clogged, resulting in overflow, low energy dissipation, and direct impingement of the erosive stream jet downstream.

A step by step procedure for the design of a baffle chute drop spillway is provided in *Design of Small Dams*. Typical design elements consist of upstream transition walls, a rectangular approach chute, a sloping apron (generally equal to the downstream slope of the basin embankment) that has multiple rows of baffle blocks and downstream transition walls. The toe of the chute extends below grade and is backfilled with loose riprap to prevent undermining of the structure by eddy currents or minor degradation downstream. The structure is effective even with low tailwater; however, greater tailwater reduces scour at the toe. The structure lends itself to a variety of soils and foundation conditions.

The steps involved in the construction of a baffle chute spillway are typical of the construction of any reinforced concrete structure, and include subgrade preparation, formwork, setting reinforcing steel, placing, finishing and curing concrete, and structure backfilling. Baffle chutes generally provide consistent, dependable hydraulic performance and are relatively straightforward to construct. Potential construction challenges include foundation integrity, water control, and managing the multiple phases of formwork, reinforcing, and concrete placement and finishing.

## 5.5 Outlet Structure

Outlet structures control release rates from storage facilities and should be sized and structurally designed to release flows at the specified rates without structural or hydraulic failure. Sizing guidance is provided earlier in this chapter with additional guidance in Volume 3 of the USDCM.

The most common design consists of a configuration that releases the WQCV (Zone 1) and the balance of the EURV (Zone 2) through an orifice plate (typically a steel plate containing a vertical column of small, equally-spaced orifices. The 100-year volume above the EURV (Zone 3) is then controlled by an orifice at the bottom of the outlet vault structure, or drop box, after spilling over the crest of the drop box. The crest of the drop box acts as a weir and its length, as well as the size of the drop box opening, needs to be oversized to account for flow area reduction by the safety grate bars and blockage by debris. Figure OS-1 in Volume 3 of the USDCM provides guidance for determining initial minimum trash rack sizes for an outlet structure. Values from this figure account for clogging and metalwork losses through the safety grate. In addition to using Figure OS-1, also ensure that the velocity through the grate unhindered by debris blockage does not exceed 2 feet per second.

Design procedures for analyzing drop box hydraulics and accounting for debris blockage are described in Sections 5.5.1 through 5.5.4. Additional discussion regarding safety grates and debris blockage can be found in Section 5.6.

The hydraulic capacity of the various components of the outlet works (orifices, weirs, pipes) can be determined using the UD-Detention Excel workbook, or other standard hydraulic equations. A rating curve for the entire outlet can be developed by combining the rating curves developed for each of the components of the outlet and then selecting the most restrictive element that controls a given stage for determining the composite total outlet rating curve. The following sections describe procedures to generate a rating curve for four example types of 100-year drop box outlet structures. See Volume 3 of the USDCM for sizing the water quality orifices and incorporating water quality features into the outlet structure.

### Drop box Design Considerations

Considerations for the cost and appearance of the structure can limit the size of the drop box. However, it is important to consider maintenance access and ensure that neither the crest of the box nor the safety grate (even when partially clogged) is limiting flow to the 100-year orifice.

Safety considerations (pinning by impingement velocity through the grate) may also dictate a larger structure. Use Figure OS-1 in Volume 3 of the USDCM to size the grate while separately ensuring that velocity does not exceed 2 feet per second through the safety grate in its unclogged condition.

Additionally, UDFCD recommends providing a rail in any location where a drop exceeds 3-feet.

### 5.5.1 Flush Safety Grate

A flush grate drop box is a grate, either bar or close mesh, that is flush with the top of the box opening. The box opening may be horizontal or constructed with the slope of the embankment (as shown in Figure 12-15).

Evaluate the top of the outlet box for both weir (A) and orifice (B) flow at increasing water depths. The lesser of the two calculated flow values will indicate which controls for a given depth. Detailed discussion regarding weir and orifice hydraulics are in Section 5.14. Apply the net weir length and orifice open area, considering blockage by grating and potential debris, as discussed in Section 5.6. UDFCD contracted with Bureau of Recreation (USBR) to construct a physical model to refine weir/orifice calculations for a sloping drop box. Equations within the UD-Detention workbook equations are based on the USBR physical model. Documented at [www.udfcd.org](http://www.udfcd.org).

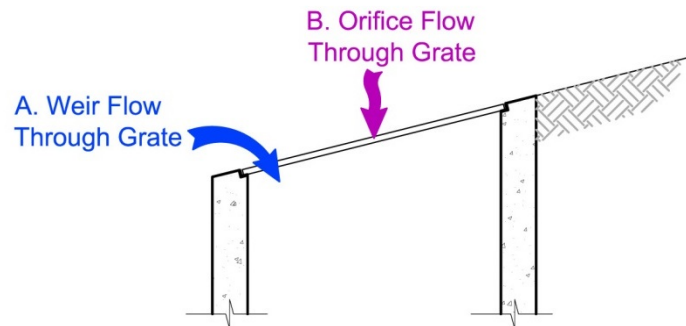


Figure 12-15. Flush grate (sloping drop box shown)

### 5.5.2 Raised Grate with Multiple Vertical Openings

A raised grate with multiple vertical openings offers improved flow capacity and resistance to debris blockage. It has vertical openings (open bar or close mesh) on two to four sides. See Figure 12-16 for a graphical representation of this grate configuration.

This outlet must be evaluated for the two separate flow conditions (listed below and shown in Figure 12-16) to determine which controls at each incremental depth:

- **A. Weir Flow:** Calculate weir flow using the drop box interior perimeter reduced for the vertical grate supports and a 10% perimeter reduction for clogging.
- **B. Orifice Flow:** Calculate orifice flow using the smaller of the interior drop box area or the total grate area reduced for metalwork and debris clogging.

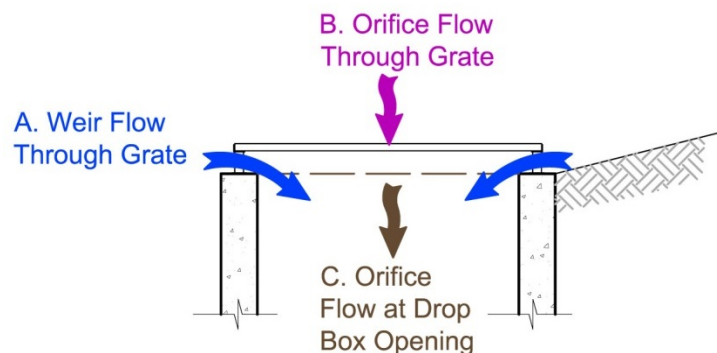


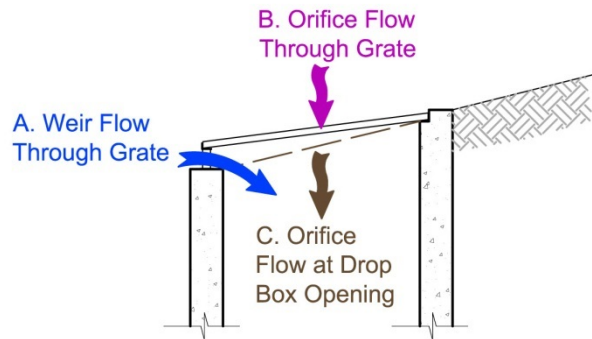
Figure 12-16. Grate with vertical openings (horizontal drop box shown)

### 5.5.3 Raised Safety Grate with Vertical Opening

A grate with one vertical opening may also offer improved flow capacity and resistance to debris blockage. Figure 12-17 provides a graphical representation of this grate configuration.

This outlet must be evaluated for the two separate flow conditions (listed below and shown in Figure 12-17) to determine which controls at each incremental depth:

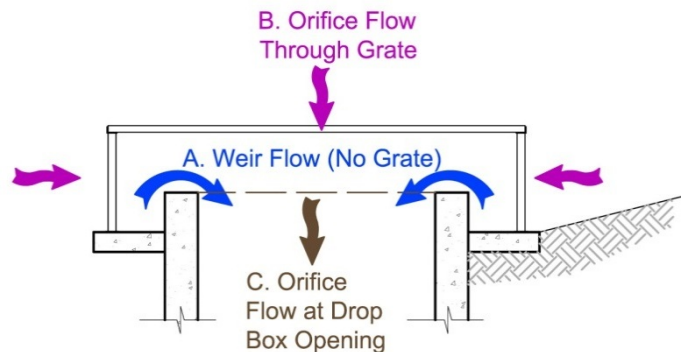
- **A. Weir Flow:** Calculate weir flow using the average of the net perimeter length (i.e., reduced for metalwork and clogging) calculated from the condition shown in Figure 12-15 and Figure 12-16.
- **B. Orifice Flow:** Calculate orifice flow using the smaller of the interior drop box area or the total grate area reduced for metalwork and debris clogging. To account for clogging, the vertical grate net opening area should be reduced by 10%, while the horizontal grate net opening should be reduced by 50%. To simplify orifice calculations at various stages for a vertical or sloping grate, use the UD-Detention workbook.



**Figure 12-17. Grate with vertical opening (sloping drop box shown)**

### 5.5.4 Raised Grate with Offset Vertical Openings

A grate with offset vertical openings is a bar or close mesh grate that is elevated and extends beyond the sidewalls of the concrete outlet structure. This results in a vertical and horizontal gap between the grate and the walls of the drop box on all four sides of the structure and provides grate area below floating debris similar to a micropool design (See Volume 3 of the USDCM). Figure 12-18 shows a horizontal grate configuration. The grate could also be sloped.



**Figure 12-18. Grate with offset vertical panels (horizontal drop box shown)**

This outlet must be evaluated for three separate flow conditions (listed below and shown in Figure 12-18) to determine which controls at each incremental depth:

- **A. Weir Flow:** Calculate weir flow over the walls of the drop box using the smaller of the unclogged drop box perimeter or the grate perimeter reduced for metalwork and 10% debris clogging.
- **B. Orifice Flow:** Calculate orifice flow using the smaller of the interior drop box area or the total grate area reduced for metalwork and debris clogging.

### 5.5.5 Outlet Pipe Hydraulics

Once the hydraulics of the top of a drop box are evaluated using the procedures discussed in Sections 5.5.1 through 5.5.4, the capacity of the outlet pipe and its orifice plate flow restrictor must be determined for increments of increasing water depth. The discharge pipe of the outlet works should be evaluated to ensure it is not under outlet control as a culvert at the 100-year (or design) discharge, and the orifice plate covering the opening of this pipe in the bottom of the drop box should be evaluated to ensure it limits flow to the required release rate. See the *Culverts* chapter for guidance regarding the calculation of the hydraulic capacity of outlet pipes. The UD-Culvert workbook can be used to determine the controlling condition of the culvert downstream of the orifice flow restrictor plate, while the UD-Detention workbook was designed to simplify these tasks.

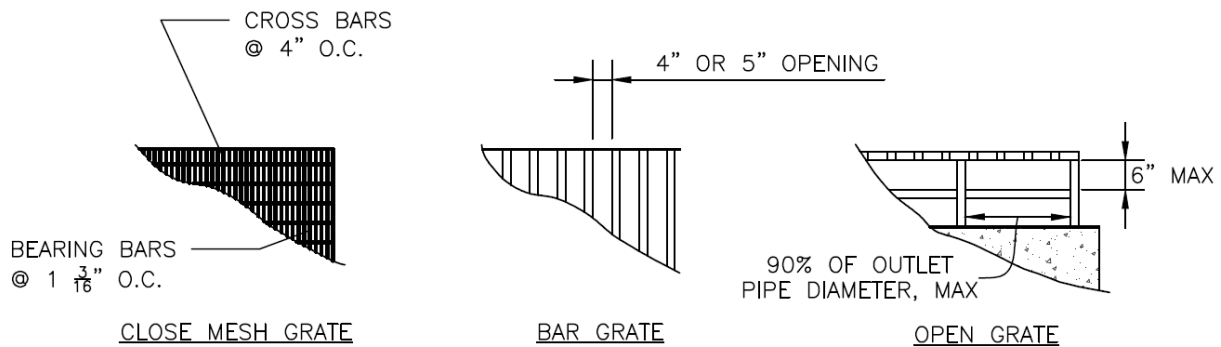
The stage-discharge relationship of the outlet pipe and orifice is then compared to the controlling stage-discharge relationship for the top of the drop box plus flow through the water quality/EURV orifices may also be added. The ultimate control of the outlet is the smaller value of the flow through the top of the drop box plus water quality/EURV orifices, and the flow through the outlet pipe orifice over the range of stage. The design goal is that the outlet pipe orifice controls flow for the 100-year event, and the grate controls for more frequent return periods.

Determining the final hydraulics of the outlet structure becomes an iterative process. A final stage discharge curve is determined by completing the steps outlined above. This stage-discharge curve and the basin geometry are then input into the UD-Detention workbook or a SWMM model to evaluate hydrograph routing and the associated maximum stage, storage volume, and release rate. Often times it will be necessary to adjust the dimensions of the outlet box or the restrictor plate and orifice area of the outlet pipe to achieve the desired outflow from the basin. The goal is to have the 100-year orifice at the bottom of the box in front of the outlet pipe control the 100-year release rate at the maximum stage, not the hydraulic condition at the top of the outlet box. A final check on the overall safety of the outlet should be made to ensure that the velocity of flow through the grate open area reduced for metalwork but not for clogging does not exceed 2 ft/s.

### 5.6 Trash Racks and Debris Blockage

Trash racks should always be installed as part of an outlet structure to reduce safety concerns. Consider maintenance of the structure and potential access by the public when selecting the type of trash rack. For example, a close mesh grate will be more appropriate in high pedestrian traffic but will require more frequent maintenance as it will catch smaller debris. Trash racks of sufficient size should always be provided on an outlet structure so that they do not interfere with the hydraulic capacity of the outlet. See figure OS-1 in Chapter 4 of Volume 3 of this manual for the minimum open area based on the outlet size.

Typically, outlet structure safety grates consist of either a bar grate, a close mesh grate or an open grate as shown in Figure 12-19 below. Close mesh and bar grates can be used for horizontal, sloping or vertical surfaces. Open grates are typically only used along vertical openings, as shown in Figures 12-16 through 12-18 of Section 5.5. Figure 12-19 provides typical dimensions for the three aforementioned grates. The open area of the grate is typically provided by the manufacturer for prefabricated grates. Alternatively, this can be calculated. It is always appropriate to apply a debris blockage reduction. This is typically 50%. In some cases, it may be appropriate to increase or decrease this value based upon the potential for debris at a specific site. Considerations should include land cover and the type of grate at a minimum.



**Figure 12-19. Typical grate configurations for outlet structures**

### 5.7 Inlets

Inlets should provide energy dissipation to limit erosion. They should be designed in accordance with drop structure or pipe outlet criteria in the *Hydraulic Structures* chapter of the USDCM, or using other energy dissipation structures as appropriate. Additionally, forebays or sediment traps are recommended to provide a location to remove coarse sediment from the system prior to it being deposited in the vegetated area of the basin. Forebays need regular monitoring and maintenance.

### 5.8 Vegetation

The type of grass used in vegetating a newly constructed storage facility is a function of the frequency and duration of inundation of the area, soil types, and the other potential uses (park, open space, etc.) of the area. UDFCD recommends use of native grasses to reduce frequency and cost of maintenance and help maintain infiltration rates. See the *Revegetation* chapter for detailed information on establishing vegetation, including soil testing and amendments, seed mixes, and plantings. A planting plan should be developed for new facilities to meet their intended use and setting in the urban landscape. Trees and shrubs are not recommended on dams or fill embankments. However, use of trees immediately outside of detention basins will not interfere with their flood control operation or increase maintenance needs significantly. Also, sparse planting of trees basins may also be acceptable as long as they are not located near inlets and outlet or on the emergency spillway(s) and will not interfere significantly with maintenance or create clogging problems with the water quality screen. On the other hand, use of shrubs on the banks and bottom, while not affecting the flood routing, can increase maintenance significantly by providing traps for a source of debris and obstructing maintenance procedures. Because storage facilities are frequently wet, they are ideal nurseries for invasive and undesirable plants such as Siberian Elms, Russian Olives, Tamarisk, etc. This unplanned vegetation should be removed annually.

### 5.9 Retaining Walls

The use of retaining walls within detention basins is generally discouraged due to the potential increase in long-term maintenance access and costs as well as concerns regarding the safety of the general public and maintenance personnel. Where walls are used, limit the length of the retaining walls to no more than 50 percent of the basin perimeter. Also, consider potential fall hazards associated with pedestrians, cyclists, and vehicles in determining the appropriate treatment between a sidewalk, path, or roadway and the top of the wall. Considerations include distance from the public to the wall, curvature of the path or roadway, single or terraced walls, surrounding land use, and volume of traffic. Potential solutions include dense vegetation, seat walls, perimeter fencing, safety railing and guardrail. In some cases walls less than 2 feet

will warrant a hard vertical barrier; in other cases a 3-foot wall may be the point at which this barrier is appropriate. Check requirements of the local jurisdiction. UDFCD recommends providing a hard vertical barrier in any location where walls exceed 3-feet.

Adequate horizontal separation between terracing walls should be provided to ensure that each wall is loaded by the adjacent soil, based on conservative assumptions regarding the angle of repose. When determining the separation between walls, consider the proposed anchoring system and the required equipment/space needed to repair the wall in the event of a failure. Ensure that failure and repair of any wall does not impact loading on adjacent walls. Separation between adjacent walls should be at least twice the adjacent wall height, such that a plane extended through the bottom of adjacent walls would not be steeper than a 2(H):1(V) slope. Slope of finished grade between walls should not exceed 4 percent. Wall designs exceeding these criteria or exceeding a height of 30 inches should only be performed by a Professional Engineer and should include a structural analysis for the design, evaluating the various loading conditions that the wall may encounter. Also consider a drain system behind the wall to ensure that hydrostatic pressures are equalized as the water level changes in the basin.

### **5.10 Access**

All weather stable maintenance access shall be provided to elements requiring periodic maintenance. Guidance for equipment access to water quality components is discussed in Volume 3 of the USDCM. This guidance may also be relevant for flood control (only) facilities.

### **5.11 Geotechnical Considerations**

The designer must take into full account the geotechnical conditions of the site. These considerations include issues related to ground water elevation, embankment stability, geologic hazards, seepage, and other site-specific issues.

It may be necessary to confer with a qualified geotechnical engineer during both design and construction, especially for the larger detention and retention storage facilities.

### **5.12 Linings**

Sometimes an impermeable clay or synthetic liner is necessary. Stormwater detention and retention facilities have the potential to raise the groundwater level in the vicinity of the basin. Where there is concern for damage to adjacent structures due to rising ground water, consider lining the basin with an impermeable liner. An impermeable liner may also be warranted for a retention pond where the designer seeks to limit seepage from the permanent pool. Note that if left uncovered, synthetic lining on side slopes creates a serious impediment to egress and a potential drowning hazard. See the Retention Pond Fact Sheet in Volume 3 of the USDCM for guidance and benefits associated with the constructing a safety wetland bench.

### **5.13 Environmental Permitting and Other Considerations**

The designer must take into account environmental considerations surrounding the facility and the site during its selection, design and construction. These can include regulatory issues such as:

- If construction will create disturbance or otherwise modify a jurisdictional wetland,
- If the facility is to be located on a waterway that is regulated by the U.S. Army Corps of Engineers as a “Water of the U.S.”, and

- If there are threatened and endangered species or habitat in the area.

There are also non-regulatory environmental issues that should be considered. UDFCD recommends early discussions with relevant federal, state and local regulators on these issues. Issues may include the following:

- Potential for encountering contaminated soils during excavation,
- Proper implementation of design elements to mitigate mosquito breeding (i.e., a micropool)
- Concern from area residents regarding the disturbance of existing riparian habitat that may be required for construction of the basin, and
- Colorado water rights issues related to large permanent pools or retention ponds.

## 5.14 Orifice and Weir Hydraulics

The following discussion regarding weirs and orifices is adapted from *Urban Drainage Design Manual*, Hydraulic Engineering Circular No. 22, Third Edition (Brown et al., 2009).

### 5.14.1 Orifices

Multiple orifices may be used in a detention facility, and the hydraulics of each can be superimposed to develop the outlet-rating curve. For a single orifice or a group of orifices, orifice flow can be determined using Equation 12-7.

$$Q = C_o A_o (2gH_o)^{0.5} \quad \text{Equation 12-7}$$

Where:

$Q$  = the orifice flow rate through a given orifice (cfs)

$C_o$  = discharge coefficient (0.60 recommended for square-edge orifices)

$A_o$  = area of orifice (ft<sup>2</sup>)

$H_o$  = effective head on each orifice opening (ft)

$g$  = gravitational acceleration constant (32.2 ft/sec<sup>2</sup>)

If the orifice discharges as a free outfall, the effective head is measured from the centroid of the orifice to the upstream water surface elevation. If the downstream jet of the orifice is submerged, then the effective head is the difference in elevation between the upstream and downstream water surfaces.

### 5.14.2 Weirs

Flow over a horizontal spillway or drop box crest can be calculated using the following equation for a horizontal broad-crested weir. See Figure 12-7 for a graphical representation of weir flow.

Horizontal Broad-Crested Weir: The equation typically used for a broad-crested weir is:

$$Q = C_{BCW} L H^{1.5}$$

Equation 12-8

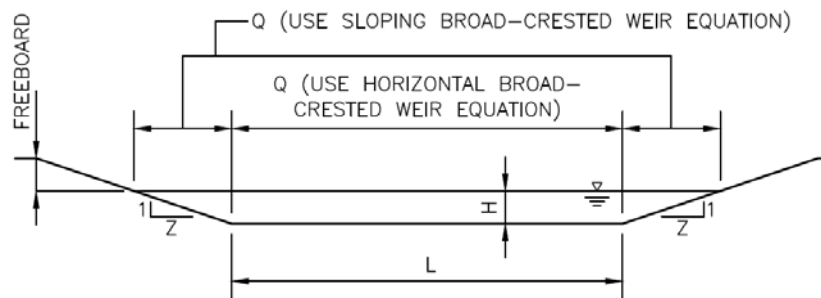
Where:

$Q$  = discharge (cfs)

$C_{BCW}$  = broad-crested weir coefficient (This ranges from 2.6 to 3.0. A value of 3.0 is often used in practice.) See Hydraulic Engineering Circular No. 22 for additional information.

$L$  = broad-crested weir length (ft)

$H$  = head above weir crest (ft)



**Figure 12-20. Sloping broad-crest weir**

Sloping Broad-Crested Weir: Figure 12-20 shows an example of a sloping broad-crested weir. The equation to calculate the flow over the sloping portion of the weir is as follows:

$$Q = \left(\frac{2}{5}\right) C_{BCW} Z H^{2.5}$$

Equation 12-9

Where:

$Q$  = discharge (cfs)

$C_{BCW}$  = broad-crested weir coefficient (This ranges from 2.6 to 3.0. A value of 3.0 is often used in practice.) See Hydraulic Engineering Circular No. 22 for additional information.

$Z$  = side slope (horizontal: vertical)

$H$  = head above weir crest (ft)

Note that in order to calculate the total flow over the weir depicted in Figure 12-20, the results from Equation 12-8 must be added to two times the results from Equation 12-9.

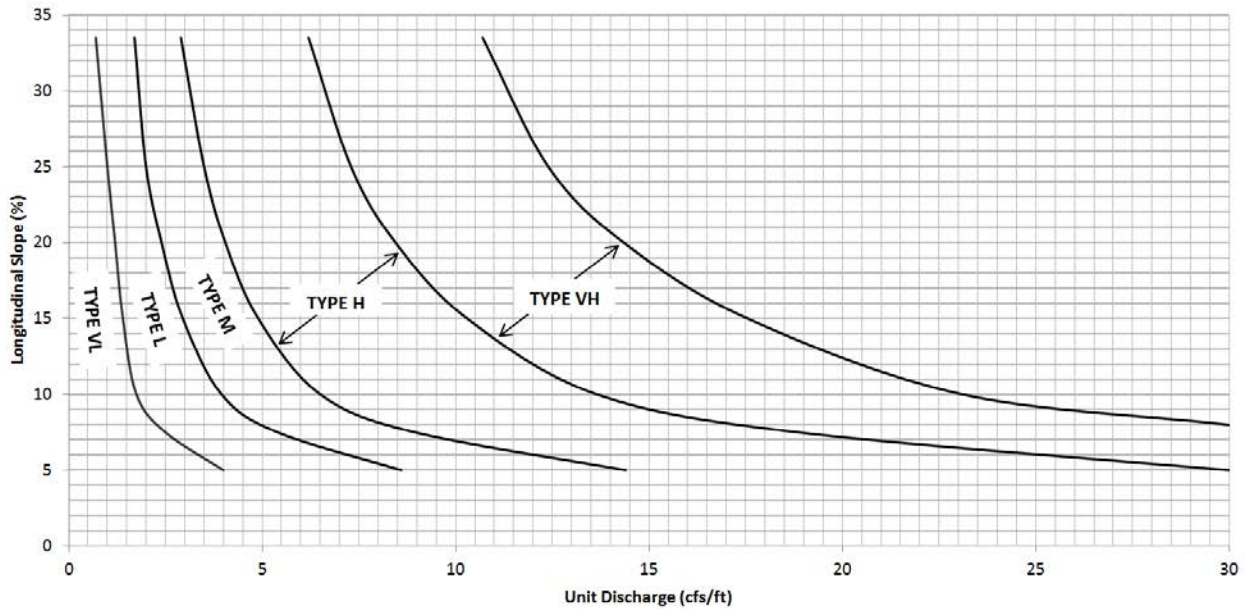
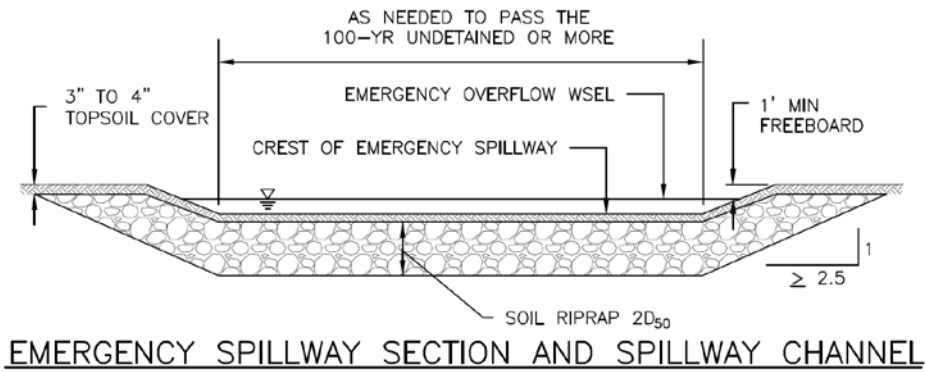
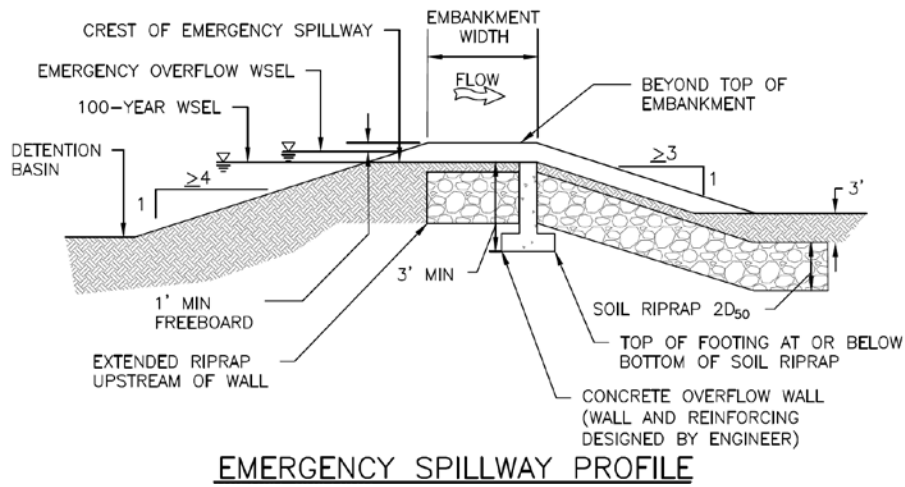


Figure 12-21. Embankment protection details and rock sizing chart (adapted from Arapahoe County)

## 6.0 Additional Configurations of Detention Facilities

In addition to regional, sub-regional, and onsite full spectrum detention facilities described in Section 2, there are a number of specialized types and configurations for storage that require special considerations.

### 6.1 Water Storage Reservoirs

Colorado State law specifically exempts the reliance of water storage reservoirs for flood control by downstream properties. If a project developer or local jurisdiction wants to utilize them for detention storage, some form of ownership of the flood storage pool and outlet function must be acquired from the reservoir owner. An agreement with the reservoir owner that ensures the continued existence of the facility or its detention function over time must be reached before relying on such reservoirs. It is also necessary to demonstrate that the embankment and spillway are safe and stable to ensure public safety.

### 6.2 Upstream of Railroad and Highway Embankments

Storage behind road, railroad, and other embankments can also be lost due to site grading and fill changes and/or the installation of larger culverts or bridges. If the designer intends to utilize roadway, railroad, or other embankments for detention storage, some form of ownership of the flood storage pool and control of the outlet must be acquired. An agreement with the roadway, railroad, or other agency that ensures the continued full flood protection benefit of the facility over time must be reached before relying on the facility. In addition, it is necessary to demonstrate that 1) roadway, railroad or other embankment stability will not be compromised, 2) embankment overtopping during larger storms will not impact upstream or downstream properties, and 3) the storage facility will remain in place as a detention facility in perpetuity.

### 6.3 Side-Channel Detention Basins

Also referred to as offline detention, this type of storage facility is located immediately adjacent to a stream and depends on a diversion of some portion of flood flows out of the waterway into the detention basin, typically over a side-channel spillway. These facilities can be used to “shave the peak” off of a flood hydrograph and can potentially be smaller and store water less frequently than on-line facilities. These facilities do not include WQCV or EURV and therefore address only flood peak reduction. They generally have limited application, but may be one of the storage alternatives considered during watershed master planning studies.

### 6.4 Parking Lot Detention

Parking lot islands or adjacent landscape areas can be desirable locations to provide WQCV or even EURV; however, it is recommended that the maximum water surface for WQCV or EURV be kept below the elevation of the pavement surface.

It is more problematic to provide 100-year detention within parking lots given the inconvenience imposed by ponding water in areas of vehicle and pedestrians use. If 100-year parking lot detention is allowed by local jurisdictions, depth limitations and signage requirements should be considered carefully.

## 6.5 Underground Detention

Because of the problems associated with placing detention “out of sight”, the difficulty and hazardous nature of access for maintenance, seepage concerns, and uncertain design life for vessels subject to corrosion, underground detention is not recommended by UDFCD. Some local jurisdictions may allow underground 100-year detention in limited high-density urban developments; in those cases, careful consideration must be given to requirements to ensure ongoing inspection, maintenance, and functionality.

## 6.6 Blue Roofs

A blue roof is a rooftop designed to provide detention. Rooftop detention was removed from this manual as part of a previous update because conventional systems could be easily manipulated by maintenance personal that viewed standing water on a roof as problematic and would make adjustments to the outlet resulting in loss of detention. Depending on the design, blue roofs can be successful in providing storage and slow release of the WQCV or larger events. To ensure long-term maintenance, the design should both appear as an intentional part of the roof design and should not be easily bypassed.



**Photograph 12-4.** This blue roof system utilizes trays. The design appears as an intentional feature to the lay person. Additionally, the design is such that it cannot be easily manipulated. Photo courtesy of Geosyntec.

## 6.7 Retention Facilities

Retention facilities (basins with a zero release rate or a very slow release rate) have been used in some instances as temporary measures when there is no formal downstream drainage system, or one that is grossly inadequate, until an adequate system is developed. However, these facilities are problematic on a number of levels. Sizing these facilities for a given set of assumptions does not ensure that another scenario produced by nature (e.g., a series of small storms that add up to large volumes over a week or two) will not overwhelm the intended design. In addition, water rights concerns and problems associated with standing water make these facilities undesirable. For these reasons, retention basins are recommended by UDFCD only as a choice of last resort.

After taking into consideration the concerns summarized above, if a retention facility is to be designed and constructed then UDFCD recommends the following design parameters. The retention facility should be sized to capture, as a minimum, 2.0 times the 24 hour, 100-year storm plus 1 foot of freeboard.

## 7.0 Designing for Safety, Operation, and Maintenance

Maintenance considerations during design include the following (adapted from ASCE and WEF 1992).

1. Use of mild side slopes (e.g., no steeper than 4(H):1(V)) along the banks and installation of landscaping that will discourage entry along the periphery near the outlets and steeper embankment

sections are advisable. Also, use of safety railings at vertical or very steep structural faces. If the impoundment is situated at a lower grade than and adjacent to a highway, installation of a guardrail is in order. Providing features to discourage public access to the inlet and outlet areas of the facility should be considered.

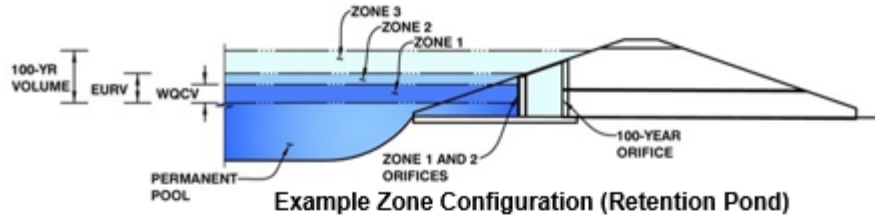
2. The facility should be accessible to maintenance equipment for removal of silt and debris and for repair of damages that may occur over time. Easements and/or rights-of-way are required to allow access to the facility by the owner or agency responsible for maintenance.
3. Permanent ponds should have provisions for complete drainage for sediment removal (or other means of sediment removal). The frequency of sediment removal will vary among facilities, depending on the original volume set aside for sediment, the rate of accumulation, rate of growth of vegetation, drainage area erosion control measures, and the desired aesthetic appearance of the pond.
4. For multiuse facilities, especially those intended for active recreation, the play area might need special consideration during design to minimize the frequency and periods of inundation and wet conditions. It may be advisable to provide an underground drainage system if active recreation is contemplated.
5. Adequate dissolved oxygen supply in ponds (to minimize odors and other nuisances) may be able to be maintained by artificial aeration.
6. Use of fertilizer, pesticides and herbicides adjacent to the permanent pool pond and within the detention basin should be avoided (this includes EPA-approved pesticides and herbicides).
7. Secondary uses that would be incompatible with sediment deposits should not be planned unless a high level of maintenance will be provided.
8. French drains or the equivalent are almost impossible to maintain, and should be used with discretion where sediment loads are expected to be high.
9. Detention facilities should be designed with sufficient depth to allow accumulation of sediment based on a sustainable frequency of maintenance.
10. Often designers use fences to minimize hazards. These may trap debris, impede flows, hinder maintenance, and, ironically, fail to prevent access to the outlet. However, desirable conditions can be achieved through careful design and positioning of the structure, as well as through landscaping that will discourage access. Creative designs, integrated with innovative landscaping, can be safe and can also enhance the appearance of the outlet and basin. When developing the landscape plan also consider landscape maintenance requirements.
11. To reduce maintenance and avoid operational problems, outlet structures should be designed with no unmonitored moving parts (i.e., use only pipes, orifices, and weirs). Manually and/or electrically operated gates should be avoided unless equipped with remote monitoring and an emergency operation plan. To reduce maintenance, outlets should be designed with openings as large as possible, compatible with the depth-discharge relationships desired and with water quality, safety, and aesthetic objectives in mind. For the 100-year discharge, use a larger outlet pipe and install a restrictor plate (orifice) to reduce outflow rates. Outlets should be robustly designed to lessen the chances of damage from debris or vandalism.

See Volume 3 of the USDCM for additional recommendations regarding operation and maintenance of water quality related facilities.

## 8.0 Design Examples

### 8.1 Example - Design of a Full Spectrum Detention Sand Filter Basin using UD-Detention

Determine the required full spectrum detention volume and approximate area for a sand filter basin to receive runoff from 20 acres in Denver. The site is 75% impervious and has NRCS hydrologic soil group C/D. The watershed slope is 0.5% and the length of the watershed is 1300 feet.



#### Required Volume Calculation

Sand Filter (SF)	SF	
Watershed Area =	20.00	acres
Watershed Length =	1,300	ft
Watershed Slope =	0.005	ft/ft
Watershed Imperviousness =	75.00%	percent
Percentage Hydrologic Soil Group A =	0.0%	percent
Percentage Hydrologic Soil Group B =	0.0%	percent
Percentage Hydrologic Soil Groups C/D =	100.0%	percent
Desired WQCV Drain Time =	12.0	hours
Location for 1-hr Rainfall Depths =	Denver - Capitol Building	
Water Quality Capture Volume (WQCV) =	0.399	acre-feet
Excess Urban Runoff Volume (EURV) =	1.466	acre-feet
2-yr Runoff Volume (P1 = 0.83 in.) =	0.977	acre-feet
5-yr Runoff Volume (P1 = 1.09 in.) =	1.406	acre-feet
10-yr Runoff Volume (P1 = 1.33 in.) =	1.776	acre-feet
25-yr Runoff Volume (P1 = 1.69 in.) =	2.434	acre-feet
50-yr Runoff Volume (P1 = 1.99 in.) =	2.945	acre-feet
100-yr Runoff Volume (P1 = 2.31 in.) =	3.557	acre-feet
500-yr Runoff Volume (P1 = 3.14 in.) =	5.040	acre-feet
Approximate 2-yr Detention Volume =	0.917	acre-feet
Approximate 5-yr Detention Volume =	1.324	acre-feet
Approximate 10-yr Detention Volume =	1.591	acre-feet
Approximate 25-yr Detention Volume =	1.878	acre-feet
Approximate 50-yr Detention Volume =	2.015	acre-feet
Approximate 100-yr Detention Volume =	2.231	acre-feet

Optional User Override  
1-hr Precipitation

	inches
	inches
	inches
	inches
	inches
	inches

Enter the watershed parameters into the blue user input cells in the *Basin* tab. A drop down box allows the user to indicate the location. Alternatively, the user may enter their own 1- hour precipitation values. The worksheet calculates the runoff and detention volumes and populates the remaining cells, as shown above.

**Stage-Storage Calculation**

Zone 1 Volume (WQCV)	0.399	acre-feet
Zone 2 Volume (EURV - Zone 1)	1.066	acre-feet
Zone 3 Volume (100-year - Zones 1 & 2)	0.765	acre-feet
Total Detention Basin Volume =	2.231	acre-feet
Initial Surcharge Volume (ISV) =	N/A	ft <sup>3</sup>
Initial Surcharge Depth (ISD) =	N/A	ft
Total Available Detention Depth ( $H_{total}$ ) =	4.00	ft
Depth of Trickle Channel ( $H_{TC}$ ) =	N/A	ft
Slope of Trickle Channel ( $S_{TC}$ ) =	N/A	ft/ft
Slopes of Main Basin Sides ( $S_{main}$ ) =	4	H:V
Basin Length-to-Width Ratio ( $R_{L/W}$ ) =	2	
Initial Surcharge Area ( $A_{ISV}$ ) =	0	ft <sup>2</sup>
Surcharge Volume Length ( $L_{ISV}$ ) =	0.0	ft
Surcharge Volume Width ( $W_{ISV}$ ) =	0.0	ft
Depth of Basin Floor ( $H_{FLOOR}$ ) =	0.00	ft
Length of Basin Floor ( $L_{FLOOR}$ ) =	196.3	ft
Width of Basin Floor ( $W_{FLOOR}$ ) =	98.1	ft
Area of Basin Floor ( $A_{FLOOR}$ ) =	19,258	ft <sup>2</sup>
Volume of Basin Floor ( $V_{FLOOR}$ ) =	0	ft <sup>3</sup>
Depth of Main Basin ( $H_{MAIN}$ ) =	4.00	ft
Length of Main Basin ( $L_{MAIN}$ ) =	228.3	ft
Width of Main Basin ( $W_{MAIN}$ ) =	130.1	ft
Area of Main Basin ( $A_{MAIN}$ ) =	29,702	ft <sup>2</sup>
Volume of Main Basin ( $V_{MAIN}$ ) =	97,168	ft <sup>3</sup>
Calculated Total Basin Volume ( $V_{total}$ ) =	2.231	acre-feet

Once the user defines each zone, the available depth for detention, basin side slopes, and length to width ratio (shown above), the workbook calculates the approximate basin geometry and volume and populates stage storage values based on this geometry and approximate routed volume.

Next, use the *Outlet Structure* tab to design outlet control for each zone of the detention basin. The workbook allows for several different outlet configurations. Filtration BMPs (i.e., sand filters and rain gardens) release the WQCV (Zone 1 for this example) through an underdrain. Zone 2 (EURV-WQCV for this example), will be drained through a circular orifice located immediately above the WQCV water surface elevation. Zone 3 (100-yr – EURV) will be released when water overtops the outlet structure (weir) and is restricted at the entrance to the outlet pipe. This example uses a restrictor plate. Selection of the outlet configuration is located at the top of the *Outlet* tab (see the screenshot below).

	Stage (ft)	Volume (ac-ft)	Outlet Type	
Zone 1 (WQCV)	0.86	0.399	Filtration Media	Filtration Media with Underdrain
Zone 2 (EURV)	2.81	1.066	Circular Orifice	Vertical Orifice (Circular)
Zone 3 (100-year)	4.00	0.765	Weir&Pipe (Restrictor)	Weir and Pipe (w/ Restrictor Plate)
		2.231	Total	

Clear Input Parameters (Including Tables)

To size the Zone 1 outlet, enter a value for “underdrain orifice invert depth” (depth from the top of the sand bed to the invert of the underdrain at the outlet). Press the “Calculate Underdrain Orifice Diameter to match WQCV Drain Time” button. The underdrain parameters are also calculated and shown below.

**User Input: Orifice at Underdrain Outlet (typically used to drain WQCV in a Filtration BMP)**

Underdrain Orifice Invert Depth =  ft (distance below the filtration media surface)

Underdrain Orifice Diameter =  inches

Calculate Underdrain Orifice Diameter to match WQCV Drain Time

(Blue cells in the next section are marked “N/A” because the user did not select this as an outlet type. Skip this section.)

Zone 2 will outlet from the basin through a circular orifice (see screenshot below). This orifice should be located immediately above the WQCV. This zone extends up to the EURV water surface elevation. The workbook pulls both of these values from the *Basin* tab. Note the stage\storage description in the first column of the table in the *Basin* tab. Press the “Size Vertical Orifice to drain (EURV – WQCV) only” and enter a value for the time to drain this volume. For this example, we specify 24 hours. The user can come back to this section any time and modify the drain time. This is typically done to meet desired drain times for various return periods.

User Input: Vertical Orifice (Circular or Rectangular)		Calculated Parameters for Vertical Orifice	
	Zone 2 Circular	Not Selected	
Invert of Vertical Orifice =	0.86	N/A	ft (relative to basin bottom at Stage = 0 ft)
Depth at top of Zone using Vertical Orifice =	2.81	N/A	ft (relative to basin bottom at Stage = 0 ft)
Vertical Orifice Diameter =	0.38	N/A	inches
			Vertical Orifice Area = 0.00 ft <sup>2</sup>
			Vertical Orifice Centroid = 0.02 feet

Size Vertical Orifice to drain (EURV - WQCV) only

Use the next section of the *Outlet Structure* tab to size the overflow weir and restrictor plate. Again, the appropriate overflow weir height populates automatically from the basin tab. This is the elevation of the EURV surface elevation in the basin. Fill in approximate values for the drop box. This example uses a square inside dimension of 4 feet for the drop box and a flat top.

Enter the depth of the invert of the outlet pipe along with reasonable values for the diameter and restrictor plate height. The workbook will resize these as needed to match a release of 90% of the predevelopment 100-year peak runoff rate per USDCM criteria. Press the “Size Outlet Pipe to match 90% of the Predevelopment 100-year Peak Runoff Rate” button. The workbook will adjust the size of the outlet pipe diameter, the height of the restrictor plate, and sizes an emergency spillway. See the screenshot below.

User Input: Overflow Weir (Dropbox) and Grate (Flat or Sloped)			Calculated Parameters for Overflow Weir				
	Zone 3 Weir	Not Selected		Zone 3 Weir	Not Selected		
Overflow Weir Front Edge Height, Ho =	2.81	N/A	ft (relative to basin bottom at Stage = 0 ft)	Height of Grate Upper Edge, H <sub>g</sub> =	2.81	N/A	feet
Overflow Weir Front Edge Length =	4.00	N/A	feet	Over Flow Weir Slope Length =	4.00	N/A	feet
Overflow Weir Slope =	0.00	N/A	H:V (enter zero for flat grate)	Grate Open Area / 100-yr Orifice Area =	6.48	N/A	should be ≥ 4
Horiz. Length of Weir Sides =	4.00	N/A	feet	Overflow Grate Open Area w/o Debris =	11.20	N/A	ft <sup>2</sup>
Overflow Grate Open Area % =	70%	N/A	% grate open area/total area	Overflow Grate Open Area w/ Debris =	5.60	N/A	ft <sup>2</sup>
Debris Clogging % =	50%	N/A	%				

User Input: Outlet Pipe w/ Flow Restriction Plate (Circular Orifice, Restrictor Plate, or Rectangular Orifice)			Calculated Parameters for Outlet Pipe w/ Flow Restriction Plate				
	Zone 3 Restrictor	Not Selected		Zone 3 Restrictor	Not Selected		
Depth to Invert of Outlet Pipe =	3.00	N/A	ft (distance below basin bottom at Stage = 0 ft)	Outlet Orifice Area =	1.73	N/A	ft <sup>2</sup>
Outlet Pipe Diameter =	18.00	N/A	inches	Outlet Orifice Centroid =	0.73	N/A	feet
Restrictor Plate Height Above Pipe Invert =	17.00	N/A	inches	Half-Central Angle of Restrictor Plate on Pipe =	2.67	N/A	radians

User Input: Emergency Spillway (Rectangular or Trapezoidal)			Calculated Parameters for Spillway			
Spillway Invert Stage =	3.80	ft (relative to basin bottom at Stage = 0 ft)	Size Outlet Plate to match 90% of Predevelopment 100-year Peak Runoff Rate	Spillway Design Flow Depth =	0.88	feet
Spillway Crest Length =	16.00	feet		Stage at Top of Freeboard =	5.68	feet
Spillway End Slopes =	4.00	H:V		Basin Area at Top of Freeboard =	0.80	acres
Freeboard above Max Water Surface =	1.00	feet	Size Emergency Spillway to pass Developed 100-yr Peak Runoff Rate			

The workbook provides output related to the drain time for each storm frequency, the ratio of peak outflow to predevelopment flow, and other pertinent information.

Routed Hydrograph Results									
	WQCV	EURV	2 Year	5 Year	10 Year	25 Year	50 Year	100 Year	500 Year
Design Storm Return Period =									
One-Hour Rainfall Depth (in) =	0.53	1.07	0.83	1.09	1.33	1.69	1.99	2.31	3.14
Calculated Runoff Volume (acre-ft) =	0.399	1.466	0.977	1.406	1.776	2.434	2.945	3.557	5.040
OPTIONAL Override Runoff Volume (acre-ft) =									
Inflow Hydrograph Volume (acre-ft) =	0.398	1.465	0.976	1.406	1.774	2.433	2.945	3.556	5.030
Predevelopment Unit Peak Flow, q (cfs/acre) =	0.00	0.00	0.01	0.08	0.23	0.60	0.82	1.12	1.77
Predevelopment Peak Q (cfs) =	0.0	0.0	0.2	1.6	4.6	11.9	16.5	22.4	35.4
Peak Inflow Q (cfs) =	5.4	19.7	13.2	18.9	23.8	32.4	39.1	47.1	66.2
Peak Outflow Q (cfs) =	0.4	0.6	0.5	0.6	2.5	11.5	18.1	20.4	39.1
Ratio Peak Outflow to Predevelopment Q =	N/A	N/A	N/A	0.4	0.5	1.0	1.1	0.9	1.1
Structure Controlling Flow =	Vertical Orifice 1	Vertical Orifice 1	Vertical Orifice 1	Vertical Orifice 1	Overflow Grate 1	Overflow Grate 1	Overflow Grate 1	Outlet Plate 1	Spillway
Max Velocity through Grate 1 (fps) =	N/A	N/A	N/A	N/A	0.2	1.0	1.6	1.8	1.8
Max Velocity through Grate 2 (fps) =	N/A	N/A	N/A	N/A	N/A	N/A	N/A	N/A	N/A
Time to Drain 97% of Inflow Volume (hours) =	12	35	25	34	38	38	37	37	36
Time to Drain 99% of Inflow Volume (hours) =	12	36	26	35	39	39	39	39	39
Maximum Ponding Depth (ft) =	0.69	2.61	1.78	2.51	2.95	3.27	3.45	3.74	4.29
Area at Maximum Ponding Depth (acres) =	0.48	0.59	0.54	0.59	0.61	0.63	0.65	0.66	0.70
Maximum Volume Stored (acre-ft) =	0.318	1.347	0.870	1.288	1.552	1.752	1.861	2.057	2.426

The maximum ponded area for this design example is 0.66 acres, while the maximum volume stored is 2.06 ac-ft.

## 9.0 References

- American Society of Civil Engineers and the Water Environment Federation (ASCE and WEF). 1992. *Design and Construction of Urban Stormwater Management Systems*. New York: American Society of Civil Engineers and the Water Environment Federation.
- Brown, S.A., J.D. Schall, J.L. Morris, C.L. Doherty, S.M. Stein, and J.C. Warner. 2009. *Urban Drainage Design Manual*. Hydraulic Engineering Circular 22, Third Edition, Publication No. FHWA-NHI-10-009. Washington, DC: Federal Highway Administration.
- Colorado Division of Water Resources, Office of the State Engineer (DWR). 2007. *Rules and Regulations for Dam Safety and Dam Construction*. Denver, CO: Colorado Office of the State Engineer.
- Federal Aviation Administration (FAA). 1966. *Airport Drainage*. Washington, DC: Federal Aviation Administration.
- Federal Emergency Management Association (FEMA). 2005. *Technical Manual: Conduits through Embankment Dams*.
- Glidden, M.W. 1981. *The Effects of Stormwater Detention Policies on Peak Flows in Major Drainageways*. Master of Science Thesis, Department of Civil Engineering, University of Colorado.
- Guo, J.C.Y. 1999a. Detention Storage Volume for Small Urban Catchments. *Journal of Water Resources Planning and Management* 125(6) 380-384.
- Guo, J.C.Y. 1999b. *Storm Water System Design*. Denver, CO: University of Colorado at Denver.
- King, H.W. and E.F. Brater. 1976. *Handbook of Hydraulics for the Solution of Hydraulic Engineering Problems*. New York: McGraw-Hill.
- MacKenzie, K. and D. Rapp. *Determination of the Excess Urban Runoff Volume (EURV) for Full Spectrum Detention Design*. 2016. Urban Drainage and Flood Control District website [www.udfcd.org](http://www.udfcd.org).
- MacKenzie, K. and D. Rapp. *Estimation of Runoff and Storage Volumes for Use with Full Spectrum Detention*. 2017. Urban Drainage and Flood Control District website [www.udfcd.org](http://www.udfcd.org).
- MacKenzie, K. and D. Rapp. *Predeveloped Peak Unit Flowrates*. 2016. Urban Drainage and Flood Control District website [www.udfcd.org](http://www.udfcd.org).
- Natural Resource Conservation Service (NRCS). August 2003. *National Design Construction and Soil Mechanics Center Technical Note – Filter Diagrams for CO-1 Structures*.
- Prommesberger, B. 1984. Implementation of Stormwater Detention Policies in the Denver Metropolitan Area. *Flood Hazard News* 14(1)1, 10-11.
- Robinson, K. M., C. E. Rice, and K. C. Kadavy. 1998. *Design of Rock Chutes*. Transactions of the ASAE 41(3) 621-26. Print.
- Stahre, P. and B. Urbonas. 1990. *Stormwater Detention: For Drainage, Water Quality, and CSO Management*. Englewood Cliffs, NJ: Prentice-Hall, Inc.
- Urbonas, B. and M.W. Glidden. 1983. Potential Effectiveness of Detention Policies. *Flood Hazard*

*News* 13(1) 1, 9-11.

U.S. Bureau of Reclamation. 1987. *Design of Small Dams*, 3<sup>rd</sup> Ed. Washington, DC: Government Printing Office.

U.S. Nuclear Regulation. 1988. *Development of Riprap Design Criteria by Riprap Testing in Flumes: Phase II*. Washington, DC.

Viessman, W. and G. Lewis. 1996. *Introduction to Hydrology*. Reading, MA: Addison-Wesley Publishing.

Wulliman, J. and B. Urbonas. 2005. *Peak Flow control for Full Spectrum of Design Storms*, Urban Drainage and Flood Control District website [www.udfcd.org](http://www.udfcd.org)

# Chapter 13

## Revegetation

### Contents

<b>1.0</b>	<b>Introduction.....</b>	<b>1</b>
<b>2.0</b>	<b>Habitat Types .....</b>	<b>1</b>
2.1	Upland.....	3
2.2	Riparian.....	3
2.3	Wetlands.....	4
<b>3.0</b>	<b>Site Preparation.....</b>	<b>4</b>
3.1	Initial Hydrologic Evaluation.....	5
3.2	Initial Weed Condition Evaluation and Control.....	6
3.2.1	Control of Annual Weeds .....	8
3.2.2	Control of Biennial and Perennial Weeds.....	9
3.2.3	Additional Weed Control Guidance for Wetland Areas.....	9
3.3	Topsoil Preservation.....	9
3.4	Soil Testing .....	10
3.5	Soil Amendment.....	14
3.5.1	Soil Amendment for Upland and Riparian Areas .....	14
3.5.2	Soil Amendment for Wetland Areas .....	15
3.6	Seedbed Preparation.....	16
3.6.1	Addressing Soil Compaction.....	16
3.6.2	Seedbed Firming .....	16
3.7	Tree Protection.....	17
<b>4.0</b>	<b>Plant Material Selection.....</b>	<b>17</b>
4.1	Plant Selection Guidance for Habitat Types .....	17
4.1.1	Plant Selection for Upland Areas .....	18
4.1.2	Plant Selection for Riparian Areas.....	18
4.1.3	Plant Selection for Wetland Areas .....	19
4.2	Seeding.....	19
4.2.1	Seeding Upland Areas.....	20
4.2.2	Seeding Riparian Areas.....	20
4.2.3	Seeding Wetland Areas.....	20
4.2.4	Temporary Seeding.....	20
4.3	Trees and Shrubs.....	21
4.3.1	Upland Trees and Shrubs .....	21
4.3.2	Riparian Trees and Shrubs .....	21
4.3.3	Wetland Tree and Shrub Plantings.....	23
4.4	Types of Tree and Shrub Plant Material .....	23
4.4.1	Plugs.....	24
4.4.2	Containerized Material.....	24
4.4.3	Bare Root.....	24
4.4.4	Balled and Burlapped.....	24
4.4.5	Cuttings.....	25
4.5	Wetland Sod/Rhizomes/Tubers.....	26
<b>5.0</b>	<b>Plant Installation .....</b>	<b>27</b>
5.1	Seeding Upland and Riparian Areas .....	29

5.1.1	Drill Seeding .....	30
5.1.2	Broadcast Seeding.....	30
5.1.3	Hydroseeding .....	30
5.1.4	Interseeding.....	31
5.2	Seeding Wetland Areas .....	31
5.3	Plug, Containerized, B&B, and Bare Root Stock Installation .....	31
5.3.1	Wetland Plugs .....	31
5.3.2	Containerized, B&B, and Bare Root Stock.....	32
5.4	Cutting Installation.....	32
5.4.1	Installing Cuttings in Riparian Areas .....	33
5.4.2	Installing Cuttings in Wetland Areas .....	33
5.5	Transplanting Wetland Plants .....	34
<b>6.0</b>	<b>Mulching .....</b>	<b>34</b>
6.1	Mulching Individually Planted Trees and Shrubs .....	35
6.2	Mulching Seeded Areas .....	35
6.3	Types of Mulch .....	36
6.3.1	Straw Mulch.....	36
6.3.2	Rolled Erosion Control Products .....	37
6.3.3	Hydromulch .....	37
6.3.4	Compost .....	38
<b>7.0</b>	<b>Maintenance.....</b>	<b>38</b>
7.1	Irrigation.....	38
7.1.1	Seeded Area Irrigation .....	39
7.1.2	Tree and Shrub Irrigation.....	40
7.2	Replacing Dead Trees and Shrubs/Spot Reseeding of Bare Areas.....	40
7.3	Vegetation Protection from Animal Predation.....	41
7.4	Weed Management.....	42
7.5	Managing Erosion in Riparian Areas .....	43
7.6	Maintenance for Created, Restored and Enhanced Wetland Areas.....	43
<b>8.0</b>	<b>Post-construction Monitoring .....</b>	<b>44</b>
<b>9.0</b>	<b>Conclusion.....</b>	<b>46</b>
<b>10.0</b>	<b>References .....</b>	<b>47</b>
	<b>Appendix A. Seed Mix Tables.....</b>	<b>66</b>

## Tables

Table 13-1.	Site preparation activities for revegetating upland, riparian and wetland habitats.....	5
Table 13-2.	Proven treatment methods and timing of treatment for common front range weeds .....	7
Table 13-3.	Viable topsoil composition for Colorado native plant establishment in upland areas .....	13
Table 13-4.	Characteristics of mature compost suitable for soil amendment.....	15
Table 13-5.	Plant material for revegetating upland, riparian and wetland habitat types .....	17
Table 13-6.	Upland trees and shrubs for revegetating sites on the Colorado front range.....	22
Table 13-7.	Common Colorado front range native riparian trees and shrubs.....	23
Table 13-8.	Classifications and typical sizes of woody plant material cuttings .....	25
Table 13-9.	Installation methods for revegetating upland, riparian and wetland habitat types .....	28
Table 13-10.	Planting/seeding schedule .....	29

Table 13-11. Sample irrigation schedule for establishing native areas .....	40
Table A-1. Upland area seed mix – loamy to clay soils .....	66
Table A-2. Upland area seed mix – sandy soil .....	66
Table A-3. Upland/transitional area seed mix – alkali soil.....	67
Table A-4. Riparian seed mix – loamy to clay soils.....	67
Table A-5. Riparian area seed mix – sandy soil .....	68
Table A-6. Riparian area seed mix – alkali soil.....	68
Table A-7. Riparian/creek edge seed mix – moist to wet soils.....	69
Table A-8. Wetland seed mix – loamy to sandy soils .....	70
Table A-9. Wetland seed mix – clay and alkali soils.....	70
Table A-10. Upland area temporary seed mix – loamy to clay soils.....	71
Table A-11. Upland area temporary seed mix – sandy soil.....	71
Table A-12. Upland area temporary seed mix –combination of soil types .....	72
Table A-13. Moist to wet area temporary seed mix – combination of soil types .....	72

## Figures

(Note: Figures 13-3 through 13-19 located at end of chapter.)

Figure 13-1. Wetland, riparian and upland habitats and planting zones.....	2
Figure 13-2. Soil textural triangle.....	11
Figure 13-3. Tree protection.....	51
Figure 13-4. Wetland sod installation with staking.....	52
Figure 13-5. Stakes.....	53
Figure 13-6. Wetland plug planting.....	54
Figure 13-7. Deciduous tree planting .....	55
Figure 13-8. Upland evergreen tree planting.....	56
Figure 13-9. Tree stake layout.....	57
Figure 13-10. Deep tree planting for B&B cottonwood species.....	58
Figure 13-11. Tree planting on slope.....	59
Figure 13-12. Tree planting on riprap slope .....	60
Figure 13-13. Shrub planting container .....	61
Figure 13-14. Willow live stakes planting.....	62
Figure 13-15. Willow bundle installation.....	63
Figure 13-16. Waterfowl grazing control .....	63
Figure 13-17. Cottonwood poling.....	64
Figure 13-18. Beaver protection.....	64
Figure 13-19. Coir mat placement and trenching detail .....	65



## 1.0 Introduction

Revegetation is critical to the proper functioning of detention basins, retention ponds, wetland basins, riparian areas. Revegetation is also necessary to stabilize adjacent areas disturbed during construction. Successful revegetation is required to close-out common regulatory permits associated with working in waterways, including stormwater discharge permits associated with construction activities and U.S. Army Corps of Engineers (USACE) 404 permits. Because of Colorado’s semi-arid climate, prevalence of introduced weeds, and difficult soil conditions encountered on many projects, revegetation can be challenging and requires proper planning, installation, and maintenance to be successful.

Urban Drainage and Flood Control District (UDFCD) recommends that engineers include a revegetation specialist (i.e., ecologist, landscape architect, and wetland scientist) who is experienced in restoration ecology and local native plant communities as part of the overall project team to assist with project planning, direction, construction observation, monitoring, and long-term maintenance supervision for revegetation aspects of drainage projects. Early involvement of qualified professionals can help to identify site constraints and site preparation requirements, identify sensitive areas that should be protected during construction, select appropriate plants and installation procedures, and develop plans for continued plant establishment once the construction phase is complete.

This chapter provides guidelines and recommendations for revegetation efforts associated with drainage and water quality facilities. The guidance addresses three habitat types: uplands, riparian areas, and wetlands. For each habitat type, guidance is provided with regard to site preparation, plant material selection and installation, maintenance and post-construction monitoring.

Many municipalities have their own seed mixes and revegetation specifications that apply to development projects. When local guidelines and criteria differ from the criteria in this chapter, the engineer and revegetation specialist should work with the municipality to determine the appropriate revegetation criteria. UDFCD may also specify additional or different site-specific requirements, depending on site-specific considerations.

## 2.0 Habitat Types

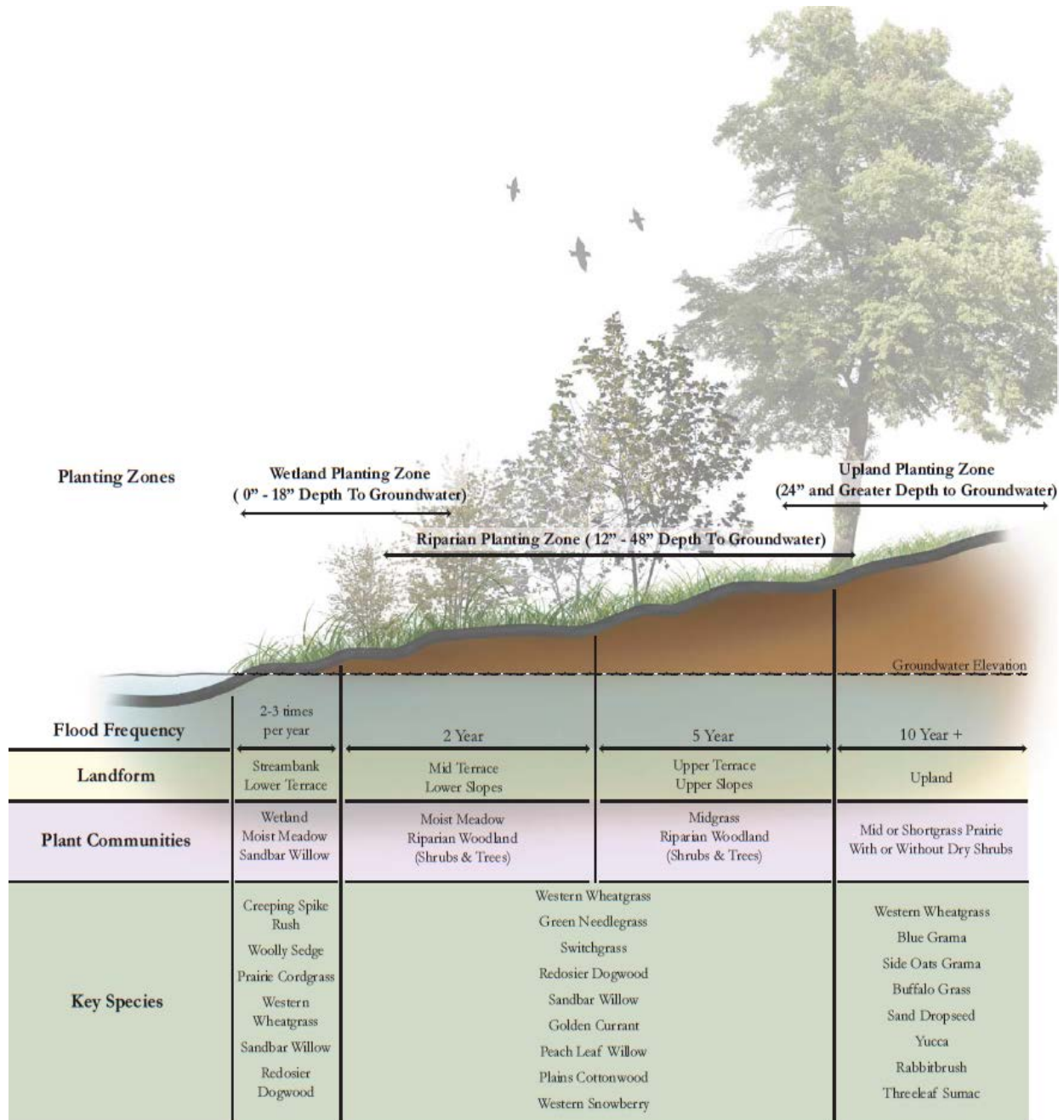
There are three general habitat types or “planting zones” encountered on drainage-related projects: upland, riparian and wetland areas. As shown in Figure 13-1, these habitat types are characterized primarily by moisture and frequency of flooding, which affect the types of vegetation appropriate for each zone. Some streams may include all three habitat types, whereas on other streams some of the habitat types may be narrow or absent.

Basic descriptions of each habitat type are provided in Sections 2.1 through 2.3. It is important to recognize that although the revegetation sequence for each habitat type is similar, each habitat type has unique characteristics requiring somewhat different approaches and challenges to revegetation. For example, proper soil preparation and weed control are particularly important for upland revegetation projects. For riparian areas,

### Cross-references to Related Urban Storm Drainage Criteria Manual (USDCM) Revegetation Criteria

- *Open Channels* Chapter: Stream Restoration, Naturalized Channels, and Swales
- Water Quality BMPs: BMP Fact Sheets for swales, buffers, bioretention and others in Volume 3, Treatment BMPs
- Construction Site Revegetation: BMP Fact Sheets for temporary and permanent seeding and mulching in Volume 3, Construction BMPs
- Extensive reference list at the end of this chapter for additional information on revegetation

addressing streambank erosion and properly assessing water levels for installation of cuttings and other plant material are important. For wetlands, adequate assessment of site hydrology to determine whether a site is capable of supporting wetlands is fundamental to success.



**Figure 13-1. Wetland, riparian and upland habitats and planting zones**

## 2.1 Upland

Native upland areas in the UDFCD area include plains grassland, shrubland, and/or woodland/forest. Plains grassland is the dominant upland vegetation type and is characterized by low-growing grasses, forbs, and scattered shrubs. Shrubland and woodland/forest are characterized by upland trees and shrubs. Upland areas can contain a combination of all three habitat types. Native upland vegetation is generally xeric, and these plants are well adapted to the UDFCD region with average rainfall of 15 inches per year. If a site is properly prepared before revegetating and the desired plant palette is correctly selected and planted in the appropriate season, average annual rainfall should be adequate for vegetation establishment (Colorado Natural Areas Program 1998).<sup>1</sup>

Common Front Range upland vegetation includes upland shrubs such as rabbitbrush (*Chrysothamnus nauseosus*), sage (*Artemisia* spp), and three-leaf sumac (*Rhus trilobata*) with an understory of upland grasses and herbaceous species. Trees are less common in the upland zone although there are several native species of both upland deciduous and coniferous trees located in this zone.

## 2.2 Riparian

Front Range riparian ecosystems are located directly adjacent to rivers, streams, creeks, ponds and other waterbodies. Riparian areas are shaped by the dynamic forces of water and are regularly inundated by rivers and streams. They provide flood control, streambank stability, nutrient cycling, stream food web support, pollutant filtering, sediment retention, and wildlife movement and migration corridors. In addition to these functions, they also provide passive recreational open space areas that are amenities in urban areas.



**Photograph 13-1.** Revegetation in progress in a riparian area along a recently constructed grade control structure. (Photograph courtesy of WWE.)

The riparian zone is generally flat with layered soils that have been deposited by previous flood events. On average, this zone floods every 2 to 5 years and is generally flat with layered soils that have been deposited by previous flood events. The riparian zone represents a transition from areas supporting water-adapted plant species to those supporting upland plant species. Common Front Range vegetation found in this zone includes an overstory of plains cottonwood (*Populus deltoides*), peachleaf willow (*Salix amygdaloides*), and box-elder (*Acer negundo*) with an understory of sandbar willow (*Salix exigua*), other native shrubs and transitional area grasses and herbaceous species. Large, inflexible trees and shrubs should not be planted in this zone because they may exacerbate flooding during high flow events by catching debris (or becoming debris).

Technically, riparian areas include several different plant communities and types of habitat, but for the purpose of this chapter, discussion of “riparian” areas generally refers to areas within the floodplain that are not wetlands.

<sup>1</sup> Because an “average” rainfall year cannot be assured, supplemental irrigation may be required for germination and establishment of vegetation in drier than average years.

## 2.3 Wetlands

As defined by the Clean Water Act (40 CFR 230.3(t)), wetlands are “areas that are inundated or saturated by surface or groundwater at a frequency and duration sufficient to support, and that under normal circumstances do support, a prevalence of vegetation typically adapted for life in saturated soil conditions. Wetlands generally include swamps, marshes, bogs and similar areas.” In lay terms, wetlands can be thought of as transitional areas between open water and dry land. Their unique character allows them to provide an array of valuable functions including water quality improvement, floodwater attenuation and storage, soil stabilization, fish and wildlife habitat, and food web support. In Colorado, creation of wetlands in excess of the wetland area disturbed and creation of wetlands where wetlands did not exist historically requires a water right.

The wetland zone along stream channels is located between the average water elevation and the bankfull discharge elevation (Figure 13-1). The lower section (near the streambank) is exposed to the highest velocity flows and typically has the highest potential for erosion (NRCS 2001b). The higher section (transitions into the lower riparian zone) is inundated less frequently and is exposed to less erosive forces. In high velocity streams, this zone may be naturally unvegetated. In lower velocity streams, it is often vegetated with water-tolerant herbaceous plant species. Flexible-stemmed willows and low-growing shrubs capable of withstanding frequent inundation should be planted in the lower section of this zone.

Common Front Range wetland species include sandbar willow (*Salix exigua*) and redosier dogwood (*Cornus sericea*) with an understory of wetland grasses, sedge and rush.



**Photograph 13-2.** A recently revegetated wetland channel. (Photograph courtesy of Iris Mitigation and Design.)

Prior to initiating a wetland revegetation plan, it is important to recognize that different types of wetland projects will require different approaches. Three general types of wetland projects include:

- Created wetlands that are constructed in upland areas that have not supported wetlands historically.
- Restored wetlands that are reestablished where a wetland existed historically but is no longer present.
- Enhanced wetlands that are existing wetlands improved to address degradation (usually human caused). Enhancement may include removing or constructing berms, filling ditches, grading, and/or modifying vegetation communities

## 3.0 Site Preparation

Initial evaluation of site conditions and appropriate site preparation are fundamental to successful revegetation for upland, riparian and wetland habitat types. Table 13-1 provides a summary of site preparation activities pertinent to each habitat type. Guidelines for each activity are provided in Sections 3.1 through 3.6.

**Table 13-1. Site preparation activities for revegetating upland, riparian and wetland habitats**

Revegetation Guidance Topic		Applicability to Habitat Type		
Activity	Chapter Section	Upland	Riparian	Wetland
Initial Hydrologic Evaluation	3.1		✓	✓
Initial Weed Evaluation and Control	3.2	✓	✓	✓
Topsoil Preservation (including Existing Wetland Soil)	3.3	✓	✓	✓
Soil Testing	3.4	✓	✓	✓
Soil Amendment	3.5	✓	✓	✓
Seed Bed Preparation	3.6	✓	✓	✓
Tree Protection	3.7	✓	✓	✓

### 3.1 Initial Hydrologic Evaluation

One of the most critical aspects for the successful revegetation of riparian and wetland areas is having sufficient hydrology to support the plants. An initial hydrologic investigation should be performed for both riparian and wetland revegetation efforts. According to Zedler and Weller (1989), understanding hydrology is the most basic and important need for a successful wetland project. During the planning process, the depth to groundwater and fluctuations in the groundwater depths should be monitored for at least one year (preferably longer, if feasible) for both riparian and wetland areas. The installation of monitoring wells and piezometers provides valuable information about groundwater levels. If limited groundwater data are available (i.e., from geotechnical reports or only one year of monitoring), it is very important to understand the data in the hydrologic context (e.g., wet year, dry year) and season in which it was collected.

As part of the wetland planning process, rigorous investigation of potential water sources should take place. Potential sources of water include groundwater, surface water, and precipitation. If the wetland's hydrology is to originate primarily from surface water, such as from a river or stream, water elevations near the proposed wetlands should be measured repeatedly during the active growing season (approximately April through September). Typically, multiple years of data are needed to make reliable determinations on water availability, since any given year may be wetter or drier than average. Groundwater levels adjacent to the stream or river should also be assessed to determine whether the river or stream is a gaining or losing system (i.e., either supplemented by the groundwater or losing water to the groundwater, respectively). In conjunction with detailed land surveys (preferably 1-foot contours), known groundwater levels and surface water levels can help to assess whether the final wetland grade will provide the hydrology necessary for supporting wetland vegetation. It is also important to consider temporary and/or periodic activities that may influence groundwater, including nearby wells, construction dewatering and/or plans for future buildings nearby that may require subterranean dewatering. Long-term monitoring wells, which may be used to collect groundwater data required for design, will require a separate state well permit.

For riparian area planning, it is important to recognize that plantings must have contact with groundwater to survive. In the semi-arid West, groundwater often fluctuates throughout the year. If the depth to groundwater precludes planting/seeding species that require more available moisture, upland (also known as xeric) plant species may need to be seeded/planted instead of riparian plant species.

### **3.2 Initial Weed Condition Evaluation and Control**

Weed infestations and, in some cases, non-native aggressive grasses that prevent the establishment of the desired native vegetation should be controlled. Ideally, weed control should be considered a year or more prior to soil disturbance. Weed control requirements should be evaluated for upland, riparian and wetland areas. For proven treatment methods and recommended treatment timing of common Front Range annual and perennial weeds, see Table 13-2. The listed weeds may be found in the habitat zone indicated and in other zones as the micro-ecology permits.

If a site has annual or perennial weed growth, weed management before revegetation is crucial for minimizing weeds and weed seed and to allow for desirable species establishment. Removing the weed seed source will help to reduce competition for soil moisture during desirable plant species establishment. Implementing weed control practices prior to and/or during construction can reduce the level of effort required for weed control later as new vegetation is becoming established. While construction activities are still on-going, maintaining weed control over the entire site, including on the topsoil stockpile, will reduce weed density once the topsoil is replaced and revegetation commences. Weed control strategies prior to construction for annual and perennial weeds are slightly different and are discussed separately in Sections 3.2.1 and 3.2.2. Weed control strategies during and following construction are included in the maintenance discussion in Section 7.4.

**Table 13-2. Proven treatment methods and timing of treatment for common front range weeds**  
(Source: Weed Research and Information Center, University of California-Davis 2013)

Common Name	Scientific Name	CO Weed List Rating	Spring Treatment	Summer Treatment	Fall Treatment
<b>Wetland Weeds</b>					
Canada thistle	<i>Cirsium arvense</i>	B	H,MM	MM	H, MM
Common teasal	<i>Dipsacus fullonum</i>	B	H		H
Eurasian watermilfoil	<i>Myriophyllum spicatum</i>	B	BI, H	MP	MP
Purple loosestrife	<i>Lythrum salicaria</i>	A	MD, MP, H, BI		
Tamarisk	<i>Tamarix ramosissima</i>	B	BI, H <sup>1</sup>	H <sup>1</sup>	H <sup>1</sup>
<b>Riparian Weeds</b>					
Leafy spurge	<i>Euphorbia esula</i>	B	BI, H		H
Poison hemlock	<i>Conium maculatum</i>	C	HP, H	HP	H
Quackgrass	<i>Elymus repens</i>	B			H
Russian olive	<i>Elaeagnus angustifolia</i>	B	H <sup>1</sup>	H <sup>1</sup>	H <sup>1</sup>
<b>Upland Weeds</b>					
Bindweed	<i>Calystegia sepium</i>	NL	BI, MP <sup>2</sup>	H	H
Bouncingbet	<i>Saponaria vaccaria</i>	B		H	H
Bull thistle	<i>Cirsium vulgare (Savi) Tenore</i>	B	MP <sup>2</sup> , BI, H, BG <sup>3</sup>	MM, BG <sup>3</sup>	H, BG <sup>3</sup>
Chinese clematis	<i>Clematis orientalis</i>	B	BG, MP	H	
Common burdock	<i>Arctium minus</i>	C	MP <sup>2</sup> , MM, H, BI	MM	MM, H
Common mullein	<i>Verbascum Thapsus</i>	C	H		H
Dalmation toadflax	<i>Linaria dalmatica</i>	B	BI, MP <sup>2</sup> , H		H
Diffuse Knapweed	<i>Centaurea diffusa</i>	B	MP <sup>2</sup> , BI, H	MM, MC, H	H
Downy brome (Cheat grass)	<i>Bromus tectorum</i>	C			H
Kochia	<i>Kochia scoparia</i>	NL	MP <sup>2</sup>	MM, H	
Myrtle spurge	<i>Euphorbia myrsinites</i>	A	H	H	H
Musk thistle	<i>Carduus nutans</i>	B	BI, MP <sup>2</sup> , MC, H, BG <sup>3</sup>	MM, BG <sup>3</sup>	H, BG <sup>3</sup>
Perennial pepperweed	<i>Lepidium latifolium</i>	B	MP <sup>2</sup> , H, BG		
Plumeless thistle	<i>Carduus acanthoides</i>	B	BI, MP <sup>2</sup> , H, MC, BG <sup>3</sup>	MM, BG <sup>3</sup>	H, BG <sup>3</sup>
Puncturevine (Goathead)	<i>Tribulus terrestris</i>	C	MP <sup>2</sup> , BI, H	MD, H	
Redstem filaree	<i>Erodium cicutarium</i>	B	MP <sup>2</sup> , H		H
Russian knapweed	<i>Acroptilon repens</i>	B	H		H
Russian thistle	<i>Salsola tragus</i>	NL	MP <sup>2</sup> , BG, H	H	
Scotch thistle	<i>Onopordum acanthium</i>	B	MD, MP <sup>2</sup> , H, BG <sup>3</sup>	MM, BG <sup>3</sup>	BG <sup>3</sup> , H
Yellow starthistle	<i>Centaurea solstitialis</i>	A	MP <sup>2</sup> , MM, BI, BG, H		
Yellow toadflax	<i>Linaria vulgaris Mill</i>	B	MP <sup>2</sup> , BI		H
Whitetop ( Hoary cress)	<i>Cardaria draba</i>	B	MM, H		H

Table Notes: <sup>1</sup>Grazing with sheep, goats and horses- no cattle. <sup>2</sup>Pull young seedlings. <sup>3</sup>Cut and treat stump if large plant or spray foliage if small plant.

Seasons: Spring = Sp, Summer = Sm, Fall = Fa. Mechanical Methods: Mowing = MM, Pulling, = MP, Cutting = MC, Digging = MD. Biological Methods: Insects = BI, Grazing animals = BG. Chemical Methods: Herbicides = H.

If herbicides will be needed to control weeds at the site, a certified applicator should be used. A copy of the applicator's license should be obtained and records should be kept of all applications that occur on the site. Only herbicides rated as aquatic safe should be used in riparian and wetland areas. A key consideration in herbicide selection should be how long the herbicide remains active in the soil (residual soil activity). No chemical residue should remain in the soil at seeding time, which could reduce desirable species germination.

In 2013, the Colorado Water Quality Control Division issued a Colorado Discharge Permit System (CDPS) General Permit for Discharges from Application of Pesticides, modeled after the U.S. Environmental Protection Agency's general permit issued in 2011. A Compliance Certification may be required for certain types of herbicide applications in Colorado.

### 3.2.1 Control of Annual Weeds

Weed management is especially useful where annual weeds are abundant. Some common annual weeds such as kochia (*Bassia sieversiana*) and cheatgrass (*Anisantha tectorum*) have short-lived seed. If weed seed production can be prevented during the year prior to revegetation of a site, it will help reduce future weed growth. Be aware that a late summer mowing of untreated annual weeds followed by plowing and seeding generally results in a rebound of many of the weedy species, so proper weed management is important prior to seeding.

For mild to moderate weed infestations, a broad-spectrum herbicide treatment may be sufficient to control weeds before revegetating the site. Be sure to check herbicide labels regarding timing of treatments because a month or more may be needed between herbicide treatments and revegetating the site (seeding) to reduce residual impact of the chemicals.

If the site has heavy annual weed growth, the soil may be deeply plowed and turned over to bury weed seed. The plowing can then be followed by disking to level the area. Once remaining weeds germinate, an application of a broad-spectrum herbicide will kill establishing weedy species. Since some topsoil is lost with this method, deep plowing to bury weed seed should only be used in an area with adequate topsoil or on historic agricultural fields. Chiseling the deep plowed area should create a level seedbed. Seedbed preparation can begin in August, prior to the fall when seeding is recommended.

#### Weed Control Considerations

- Consider weed control prior to construction to reduce competition with desirable vegetation during establishment.
- The label is the law! Follow herbicide label directions provided by the manufacturer.
- Controlling weeds by spot spraying and backpack applications is best for precise weed control treatments.
- Check to be sure that the county or other agency jurisdiction does not have the area designated as part of their weed control area – boom spraying may wipe out a revegetation effort.
- Cross-boundary weed control agreements may be needed with adjacent land management teams for more effective weed control in an area.

### 3.2.2 Control of Biennial and Perennial Weeds

Ideally, control of biennial and perennial weeds should also begin a year or more prior to seeding a site to reduce competition with the seeded species. If project timing does not allow for weed control to precede construction, it may be implemented as the site is being prepared for revegetation, and weed control may still be necessary even if it is initiated prior to construction. Spring and fall are good times for spot herbicide treatment of developing rosettes (first year stage) of many biennial species and some perennials weeds. Spring and fall are especially good for common regional weeds including Canada thistle (*Cirsium arvense*), musk thistle (*Carduus nutans*), scotch thistle (*Onopordum acanthium*), common teasel (*Dipsacus fullonum*) and knapweed (*Centaurea diffusa*). Always follow herbicide label recommendations for best treatment times and chemical mixtures for specific weed species.

#### Seeding Failures

“Inadequate weed suppression causes more seeding failures than any other single factor.”

--NRCS, 1997

### 3.2.3 Additional Weed Control Guidance for Wetland Areas

Cattails are native wetland plants which can form dense stands. If required for maintenance, deeply rooted cattails (*Typha latifolia* and *T. angustifolia*) may be controlled by fall application of aquatic labeled glyphosate followed by cutting the plant after the plant has died.

If an existing wetland is to be enhanced, elimination of undesirable species, such as reed canarygrass (*Phalaris arundinacea*) may be necessary. Herbicide application is generally the most effective means to eliminate a weedy species prior to planting. In wetland areas supporting weedy species, an EPA-approved aquatic use herbicide (such as glyphosate without polyethoxylated amine (POEA) surfactant) may be spot applied by a licensed applicator prior to planting and seeding. Repeat application of herbicide every two weeks on remaining green growth. Allow two to three weeks after the last application prior to planting.

### 3.3 Topsoil Preservation

In undisturbed upland areas along the Front Range of Colorado, native topsoil depths vary. During construction activities, topsoil should be stripped and stockpiled separately from either sub-soil or wetland soil. In order to preserve soil microbes, which are helpful with plant establishment, it is best to limit topsoil stock piles to a height of 10 feet. Topsoil also supports mid and late seral species and can therefore promote the transition from an early, weed-dominated stage to a later, native-dominated stage (Goodwin et al. 2006). Once stockpiled, the topsoil may be seeded with a sterile non-native grass or a native seed mix, depending on how long it will remain. Use native seed when the stockpile will remain for over one year. Temporary vegetation will assist in stabilizing the topsoil to reduce erosion and weed infestations. Exotic perennial grasses such as smooth brome (*Bromus inermis*), crested wheatgrass (*Agropyron cristata*) and intermediate wheatgrass (*Thinopyrum intermedium*) should not be used for temporary cover on topsoil stockpiles because they will be difficult to eradicate later. Other aggressive non-native grass species to avoid include timothy (*Phleum pratense*), orchard grass (*Dactylis glomerata*), tall fescue (*Schedonorus arundinaceae*) and meadow fescue (*Schedonorus pratense*). These exotic species are competitive and difficult to control when revegetating a project. Any soil containing weeds, such as reed canarygrass (*Phalaris arundinacea*) and Canada thistle (*Cirsium arvense*), will require great effort to control, and if possible should not be used (NRCS 2001a).

Once construction is complete, the topsoil can be spread before re-seeding and/or planting. Protecting the native topsoil is important because importing topsoil later is both labor intensive and expensive. If

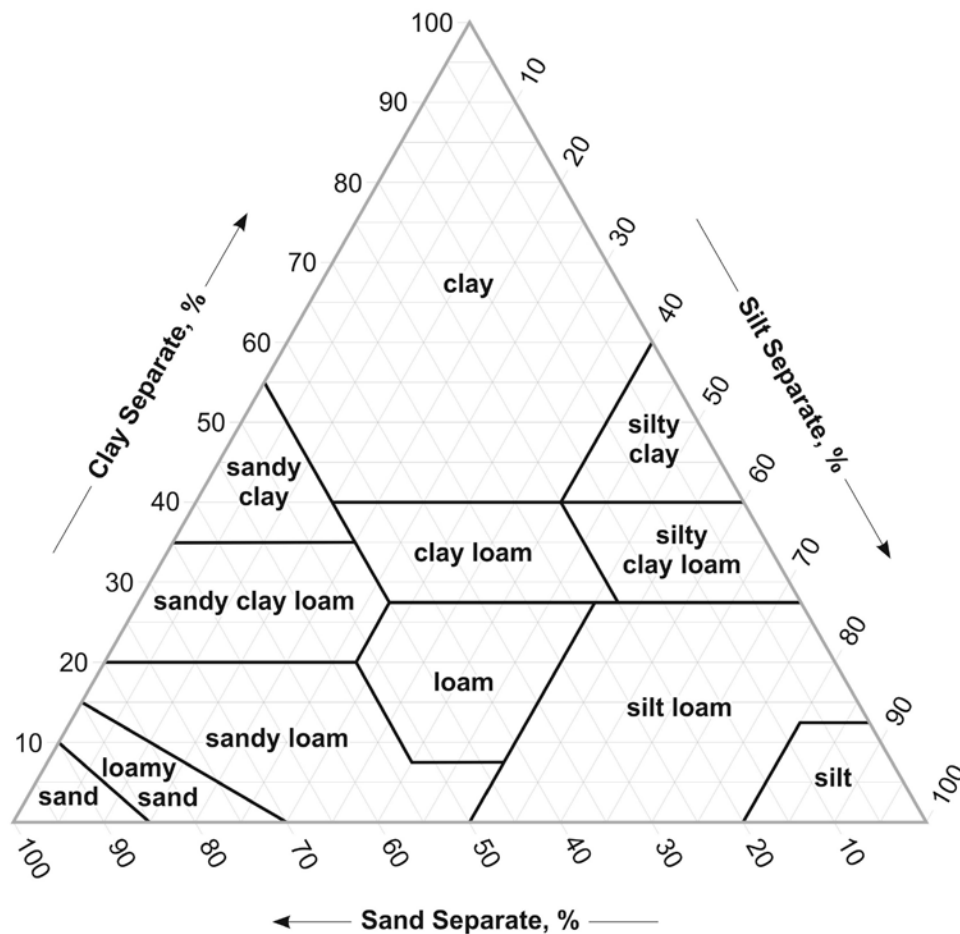
stockpiling of topsoil is not possible, subsoil can be amended and decompacted before the site is revegetated (Colorado Natural Areas Program 1998). While this is an option, the seeding results will likely be less successful as those where topsoil is available.

Topsoil may be salvaged from a wetland that will be destroyed (on-site or at another location). A study by Brown and Bedford (1997) showed that wetlands with transplanted wetland soil exhibited higher plant cover and greater diversity than areas that did not receive transplanted wetland soil. Wetland topsoil contains seeds, roots, rhizomes, tubers and other fleshy propagules that can aid in revegetation. The top 8 to 10 inches should be scraped with a front-end loader and transported to the site where it will be applied. Ideally, the topsoil should be spread out on the new wetland immediately, to a depth of no more than 6 inches. Although wetland topsoil can be stockpiled for short periods, it will lose viability. Stockpiles should be kept for less than 4 weeks, should measure less than 3 x 3 feet (height/width) (NRCS 1997). Wetland topsoil should not be stockpiled during the summer because it will compost, and the seeds and propagules will be killed.

### **3.4 Soil Testing**

Soil testing of both native and imported topsoil is recommended to select appropriate plant species for a site and to determine what types of soil amendment are required, if any. Soil samples can be delivered to a local soil testing laboratory, agricultural extension service, or university service for analysis. A standard agronomic test (e.g., nutrients, organic matter, and salinity), as well as full textural analyses, should be required for all topsoil fractions imported or salvaged from the site. Table 13-3 provides general guidance for viable topsoil composition for the establishment of native plants in upland areas in Colorado.

For upland areas along the Colorado Front Range, soil textures vary greatly. Soil texture characterizes a soil based on the size of particles found in a particular sample. Soil texture is described as sand, clay, and/or silt based on particle sizes (Figure 13-2). A U.S. Department of Agriculture (USDA) soil texture triangle diagram shows the types of soil texture combinations that are possible. Knowing the soil texture on a site will help with appropriate plant selection (Colorado Natural Areas Program 1998) and evaluation of potential for soil moisture retention. Plants are generally adapted to certain soil types although some plants can establish in a combination of soil types.



**Figure 13-2. Soil textural triangle**

When collecting soil samples and reviewing analysis results, follow these guidelines:

- Soils should be evaluated during design (visually and by lab analysis). Observation of soil prior to salvage may help determine quality of the soil to support herbaceous growth and presence of noxious weeds. Soils tests (both agronomic and full textural analyses) should be obtained during construction because grading activities and the process of stripping and stockpiling can result in very different conditions.
- The revegetation specialist and the contractor should work together to identify soil sampling locations based on planned earthwork. It is advisable for the contractor to visit the site with the revegetation specialist to understand the depth and character of the topsoil to be stockpiled. Observation of the soil source areas in the field is necessary to assist with determination of quality of the soil as a topsoil source.
- Salvage piles should be labeled and not mixed or moved until just before reapplying.
- In some cases, the subsoil should also be tested for suitability as a plant growth medium. In general, shale or weathered clay stone should be exported from the site and should not be within 18 inches of the surface. At least 18 inches of suitable subsoil and topsoil should be provided in areas that will be revegetated.

- If topsoil is to be imported from an off-site location, it is best to test it separately before it is brought on-site to be sure that it is good quality topsoil for the project. Soil amendments may still be (and often are) needed once a topsoil is brought on-site and reapplied to the existing subsoil.
- Soil test recommendations are usually geared toward agricultural crops, which may require substantially more soil amendments than what are necessary for native plant establishment. When submitting the samples, be sure to inform the testing laboratory that the soil testing is related to native plant establishment and that recommendations on soil amendments should be geared for this type of plant establishment.
- Soil test results should then be reviewed by a revegetation specialist who is familiar with the project so that the proper soil amendments are applied for the type of vegetation that will be seeded/planted.
- Saline soil conditions require special attention to plant species selection. When soil electrical conductivity is greater than 3 to 6 mmhos/cm, then saline soil conditions may be problematic (sensitivity also depends on plant species) (Swift and Koski 2007; Cardon et al. 2007). This condition commonly occurs in clay soils where the natural leaching of salts is limited. Both the surface and subsoils should be tested for salinity. If the soils are found to be highly saline, plant species should be chosen that are adapted to these conditions. CSU Cooperative Extension has developed lists of salt tolerant plants (Swift 1997; GreenCO 2008). Other research is ongoing to test the salinity tolerance of a range of riparian plant species (Goodwin et al. 2006). Native grass seed mixes of species that can tolerate more saline soil conditions are provided in Appendix A of this chapter.

**Table 13-3. Viable topsoil composition for Colorado native plant establishment in upland areas**

<b>Chemical Attributes</b>	<b>Preferred Range</b>		<b>Additional Description</b>
pH	6.0-7.5		A pH < 6 indicates possible acid problems, and pH > 8.0 indicates an alkaline soil. A pH > 8.5 indicates possible sodium problems. Most nutrients are most available to plants around a pH of 6.5.
Organic Matter	1-3%		Desirable range for good topsoil is a minimum of 1%.
Salinity	EC < 3 - 6 mmhos/cm		The desired EC varies depending on the plant selected, but EC values >2 mmhos/cm could indicate a problem for germination.
Sodium Absorption Ratio (SAR)	<6		SAR provides an indirect measure of percent exchangeable sodium on the soil colloid.
Free Lime	<10		Free lime represents the carbonates of calcium and magnesium which are not combined in the soil. Values > 10 may indicate a high amount of “lime”, poor soil structure, and an increase in water and wind erosion susceptibility. Plant-available phosphorus may be reduced because of this condition.
Cation Exchange Capacity (CEC)	12-25		Exchangeable cations include calcium (Ca <sup>2+</sup> ), magnesium (Mg <sup>2+</sup> ), sodium (Na <sup>+</sup> ), and potassium (K <sup>+</sup> ).
Saturation Percentage	> 25 and <80		Saturation percentage is the amount (percentage by weight) of water needed to saturate a soil. Values >80 may indicate high montmorillonite clay content and/or high quantities of exchangeable sodium, whereas values < 25 may indicate coarse soil materials with a low water-holding capacity. The full soil textural analyses may also report the clay content directly.
<b>Minimum ammonia DPTA (chelate) Extractable Nutrients</b>			Nitrogen (N) – Phosphorus (P) – Potassium (K): ratio of important elements in a fertilizer or soil amendment. Nitrogen is responsible for strong stem and foliage growth. High nitrogen levels favor quick-growing invasive weeds, while low nitrogen levels favor slow-growing, late-seral species (Goodwin et al. 2006). Phosphorus aids in healthy root growth and flower and seed production. Potassium improves overall health and disease resistance.
Nitrogen	5 ppm air dried basis		
Phosphorus	5-12 ppm		
Potassium	20-50 ppm		
Iron	3-5 ppm		
<b>Texture Class</b>	<b>% of Total Weight</b>	<b>Average %</b>	Soil Texture by Hydrometer Method provides the percentages of sand, silt, and clay in the soil. There are 12 textural designations (excluding modifiers such as very fine, cobbly, etc.) which can appear on a soil report. Each of these designations has a range of percentages of sand, silt, and clay, which could apply. Suitable soil textures for good topsoil material are silt loam, loam, silty clay loam, very fine sandy loam, and fine sandy loam. Soil textures with greater amounts of clay or sand can be problematic for achieving revegetation success.
Sand (0.05-2.0 mm diameter)	25 to 65	5	
Silt (0.002-0.05 mm diameter)	20 to 50	30	
Clay (<0.002 mm diameter)	20 to 30	25	

### 3.5 Soil Amendment

Depending on the results of soil tests, soil amendments may be required, particularly when test results fall outside of desired ranges in Table 13-2. Wetland areas typically do not require soil amendments. Soil amendment for upland and riparian areas is discussed in Section 3.5.1 and conditions where wetland soils may require amendment are discussed in Section 3.5.2.

#### 3.5.1 Soil Amendment for Upland and Riparian Areas

Once the soils have been tested, amendments may be needed to improve soil conditions (e.g., nutrients, soil chemistry) or texture prior to revegetating the site, particularly for upland and riparian sites. The revegetation specialist should review the soil test results and identify soil amendments that may be needed. As long as the proper soil-specific seed mixtures are used, most native topsoil can be revegetated with little or no amendment beyond the addition of a slow-release organic fertilizer.

Fertilizers may have a positive, negative, or neutral effect on the survival and growth of planted species (NRCS 2001a). Nitrogen fertilizers should be used only when soil tests show a gross nitrogen deficiency because they can stimulate annual weeds and may pollute waterbodies if applied in lower riparian zones. In some cases, nitrogen fertilizers can decrease valuable mycorrhizal activity (Goodwin et al. 2006). Nitrogen is rarely needed for native species, which have evolved in low nutrient environments characteristic of prairie grasslands. If fertilizer is expected to have a beneficial effect on seeded species, it should be added shortly before or shortly after seeding (Goodwin et al. 2006) and in accordance with soil test results.

If the original topsoil from a site is stockpiled and then replaced, soil amendments may not be required to successfully revegetate the site. If amendments are needed based on the soil test, amendments may include a slow-release organic fertilizer (such as 4-6-4 or 7-2-2 N:P:K), compost, peat, humates, sulfur, gypsum, lime, wood chips and soil micro-organisms. Application of chemical fertilizers should be avoided as this can stimulate annual weeds and may contaminate water bodies if applied in lower riparian zones.

For upland sites, most sites with low organic matter (including overworked agricultural soils, steep slopes, and sub-soils) will benefit from the addition of between 800 to 1200 pounds per acre of a slow-release organic fertilizer. This organic fertilizer is often granular and low in phosphorus. Organic fertilizers are useful for high-use areas such as park sites, along roads, and highly visible native turf areas. Chemical fertilizers generally have higher phosphorus and nitrogen levels, which encourage weedy growth that may compete with the desirable planted/seeded species. Chemical fertilizers or fertilizers produced from poultry waste are often fast-release, which encourages weed establishment. The applicator should understand the quantities/rates of fertilizer needed to avoid over fertilizing an area. Soil amendments should be applied prior to the final tilling of the soil, and should be incorporated at least 6 inches into the soil.

Soils which are low in organic matter can be amended with an approved composted material to improve soil texture. Manure is usually not recommended (NRCS 2001a). Usually, 2 cubic yards of quality compost per 1000 square feet is adequate to improve the organic content of poor soils for native revegetation. (If the revegetation effort will be in a manicured area where turf will be installed, 3-5 cubic yards per 1000 square feet is recommended. See GreenCO [2008] for more information on turf areas.) Organic matter should be incorporated at least 6 inches into the soil by tilling the soil 8 to 12 inches until no clumps or areas of thick compost remain on the surface. Table 13-4 summarizes the characteristics of mature compost that are suitable for organic matter soil amendments.

**Table 13-4. Characteristics of mature compost suitable for soil amendment**

<b>Maturity Indicator</b>	<b>Desired Result</b>
Ammonia N/Nitrate N Ratio	<6
Carbon to Nitrogen Ratio	<18
Percentage of Germination and Vigor	80% or more for both germination and vigor
pH	5.5-8.0
Soluble Salts Concentrations	2.5 dS (mmhos/cm) or less preferred
Particle Size	Pass through 1-inch screen or smaller
Moisture Content	35% - 55%
Maturity/Growth Screening	Demonstrate ability to enhance plant growth
Stability	Stable to highly stable, providing nutrients for plant growth
Organic Matter Content	30% - 70%

In upland and riparian areas, the addition of soil microorganisms can aid the establishment of native vegetation. Soil microorganisms process mulch and dead plant material into nutrients that are available for plant uptake. Common microorganisms present in soil include bacteria, protozoa, and mycorrhizal fungi. Mycorrhizal fungi adhere to roots and develop a beneficial relationship with the plant by improving nutrient uptake, drought tolerance, and pathogen resistance (Goodwin et al. 2006). They are plentiful in the litter layer of established plant communities. For riparian areas, if an adjacent riparian area has a rich layer of litter and a lack of weeds, some of the litter can be collected and mixed in with the seed mix to be applied to the riparian area to be revegetated. Mycorrhizal fungi are also available commercially.

Other amendments, such as polymer and vermiculite root dips are generally not necessary and may be detrimental (NRCS 2001a). Similarly, special treatments for willow and cottonwood cuttings (such as rooting hormones and fungicides) are unnecessary (Hoag 1998). These cuttings root easily without special treatments.

### **3.5.2 Soil Amendment for Wetland Areas**

In general, wetland revegetation projects do not require soil amendments. Wetland plants can successfully establish in a wide range of soil textures, from heavy clay with no organic matter to coarse gravels (NRCS 2011). In particular, the use of mulch is not recommended (EPA 1994), and fertilizers are rarely necessary or helpful (Colorado Natural Areas Program 1998, NRCS 2003). The addition of fertilizers may be especially detrimental by favoring the growth of weed species in the wetland and contributing to nutrient overloads already present in many waterways. However, each site is unique. To determine whether specific fertilizers may be necessary for a given project, the soil should be tested and compared with the optimum nutrient conditions for the species to be planted (Colorado Natural Areas Program 1998).

A notable exception to this generalization includes wetland creation projects in which the topsoil is removed (excavated) to reach the appropriate grade and the subsoil is exposed without replacing the topsoil. In these situations, virtually all of the naturally-occurring nutrients have been removed. Unless water entering the wetland has a high nutrient load, fertilization will probably be necessary (NRCS 2003). Not surprisingly, studies have shown that without suitable soil conditions, wetland creation projects tend to provide lower functions than natural wetlands (Bruland and Richardson 2005). In particular, soils in created wetlands tend to have a lower organic content than natural wetlands (Fajardo 2006).

### 3.6 Seedbed Preparation

When seeding is used to revegetate a site, then seedbed preparation is required and generally consists of decompacting the soil, adding soil amendment (if needed), and then firming the soil surface prior to seeding.

#### 3.6.1 Addressing Soil Compaction

Soil compaction in upland, riparian and wetland areas is a common problem for revegetation. Seedbed preparation (tilling) is crucial before revegetating a site. Compaction can be found in naturally occurring soils with high clay content or can result from heavy equipment at construction sites, cattle grazing, working soils when wet, and other causes. When soil is compacted, seeds and plant roots and rootlets cannot penetrate through the hard surface and less oxygen is available for plant establishment and growth. Less water is available for plant establishment due to the hard compacted soil surface, and the site may be vulnerable to excessive runoff due to less water penetration. Microorganisms may be inhibited due to both a lack of oxygen and large pore space needed to survive. Loss of microorganisms leads to a further degraded soil unsuitable for plant growth and affects the nutrient cycling in soils (Natural Resources Conservation Service [NRCS] 1998).

Decompaction will allow water to more easily penetrate into the soil where it can be used by roots and will enhance infiltration on the site, reducing the potential for runoff, especially during smaller, frequent events. Special attention should be given to staging areas, roads, and other high traffic areas that are severely compacted. Decompaction should occur in two steps:

- Before the topsoil is replaced, the sub-soil should be ripped to a depth of 12 inches. This can be accomplished by disking, ripping, plowing, and rototilling, made more effective by ripping in two directions perpendicular to each other. An effective method to reduce soil compaction in created and restored wetlands is to use a chisel plow to mechanically rip both the topsoil and subsoil layers prior to planting (Bantilan-Smith et al. 2009). This process is more difficult to complete on slopes greater than 3:1. On steeper slopes, a track hoe and with a ripper tooth can be used to decompact soil to the proper depth.
- Once the sub-soil is ripped and the topsoil is replaced, soil amendments should be added, if needed per the soil test and habitat type, then the soil should be tilled to 6 inches, leaving no clod over 3 inches in diameter.

These two processes will allow for a total of 18 inches of decompaction, thus providing a better growing medium for native vegetation.

#### 3.6.2 Seedbed Firming

Once the final tilling is completed, fine grading will ensure a smooth seeding/planting surface. The soil surface should be relatively firm as described for each habitat type:

- For upland and riparian areas, the soil surface should then be prepared for seeding so that a footprint will imprint between  $\frac{1}{4}$  to  $\frac{3}{4}$  inch only (NRCS 2011b).

#### Cultipacker

A cultipacker is an agricultural implement used to crush dirt clods, remove air pockets, eliminate cracks, and bury small stones to form a smooth, firm seedbed. The cultipacker is used after ripping or disking the soil as a secondary tillage. It can be used either before or after seeding to firm the seedbed and to eliminate air pockets. After broadcast seeding the cultipacker can be used to gently firm the soil around the seeds, ensuring shallow seed placement and excellent seed/soil contact.

- For wetland areas, the surface is considered firm enough when a person's footprint penetrates ¼ to ½ inch deep (NRCS 1997). Some newly created wetlands may be very difficult to firm. If necessary and when possible, firming of wetlands may be achieved by disking followed by rolling or harrowing just prior to seeding (NRCS 2008).

Firming of the seedbed soil should be performed prior to seeding, particularly if seeding in late spring or summer. Natural precipitation can sometimes be heavy enough to settle the worked soil, but waiting for such rainfall may not be realistic. If soils are sandy and contain a small amount of moisture already, a cultipacker can be used to firm the seedbed soil. Soils that are wet or silt loam to clay loam should not be cultipacked because they can become too firm, making drill seeding or crimping much less successful. Chiseling after plowing may adequately firm finer textured soils. It is also possible to firm the soil with irrigation following seeding and mulching.

### 3.7 Tree Protection

Protection of existing trees is an important aspect of site preparation, which should occur at the beginning of the construction phase. Figure 13-3 provides a detail for installation of construction fencing to protect existing trees.

## 4.0 Plant Material Selection

Appropriate plant selection is crucial in successful native revegetation of upland, riparian and wetland sites. A site plan should be created by a revegetation specialist trained in native vegetation restoration. A variety of plant materials can be used to revegetate a site. The materials used will depend greatly on budget as well as the schedule and goals of the project. Generally, these materials include seed, plugs, containerized plant material, balled and burlapped (B&B) trees and shrubs, cuttings, and transplanted plants (particularly in the case of wetlands). Table 13-5 identifies plant materials typically used in each habitat type, followed by guidance related to plant selection, seeding, and trees and shrubs.

**Table 13-5. Plant material for revegetating upland, riparian and wetland habitat types**

Revegetation Guidance Topic		Applicability to Habitat Type		
Plant Material	Chapter Section	Upland	Riparian	Wetland
Seed (permanent and temporary)	4.2	✓	✓	✓ (limited)
Plugs	4.4.1	✓	✓	✓
Containers	4.4.2			
Bare Root	4.4.3	✓	✓	✓
Balled and Burlapped (B&B)	4.4.4	✓	✓	✓
Cuttings	4.4.5		✓	✓
Wetland Sod, Rhizomes, Tubers	4.5			✓

### 4.1 Plant Selection Guidance for Habitat Types

Plant selection guidelines for upland, riparian and wetland areas differ somewhat and are discussed separately below. See Figure 13-1 for a summary of planting zones within each habitat type.

### 4.1.1 Plant Selection for Upland Areas

When present, a nearby reference site with similar conditions (soils, slope, and aspect) should be examined to assist with plant selection for upland areas.

Upland sites are generally revegetated by seeding with a native seed mixture selected based on the soil texture and to a lesser extent, chemistry. Seeds are best obtained from a local nursery and regional seed mixtures have been found to be successful in most of the soil conditions which occur in the Colorado Front Range. Sites with sandy soils or elevated salinities ( $EC > 3$ ) should use alternative seed mixtures for those soil conditions.

Plant materials used to revegetate upland areas may include also include grass and herbaceous species plugs, containers, bare root, B&B plants, and cuttings.

Regardless of the plant material selected, several general principles should be considered. First, the genetic source of the plant material may affect the long-term revegetation success. Plant material that originates in proximity to the revegetation project will be better adapted to the local area's environmental conditions, may be more resistant to pests, and may exhibit more robust growth over the long term. Similarly, plant species should be chosen that closely match the environmental conditions at the project site. Such plant species are typically adapted to water availability, salinity, elevations, and soil conditions.

Seeding is generally not feasible for establishing trees and shrubs. However, containers, and bare root plant material can be good options for both herbaceous and woody plant species.

### 4.1.2 Plant Selection for Riparian Areas

Evaluating reference sites on the same watercourse at a similar elevation may be particularly useful when revegetating riparian areas. However, many urban streams are degraded, and healthy native vegetation useful for reference areas may not be present nearby. When good reference sites exist, these areas should be assessed for the species present, the types of plant forms present (herbaceous, shrubs, or trees), and the location of species and plant forms relative to the stream. In the absence of a nearby reference area, it is possible in to rely on a proven regional riparian plant palette for most projects because riparian areas along the Front Range are typically very similar in species composition.

Unlike riprap and other inert materials, riparian plants are able to bend during high flow events and/or regenerate following flooding or other natural disturbances. This means plant selection is particularly important when revegetating riparian areas. If the appropriate species are chosen and planted in the proper locations, the entire project can be "self-healing" following disturbance (NRCS 2005b).

A primary limiting factor in semi-arid environments is water availability. This is particularly true in riparian areas where the soil moisture varies dramatically with the distance from the watercourse. Vegetation plans should reflect a gradient of vegetation from the streambank/wetland edge to the upper stream terrace areas. Use at least two seed mixtures to cover this gradient and plant woody species where they are best adapted to the hydrology.



**Photograph 13-3.** An upland area vegetated with native grasses along a riparian corridor in open space area. (Photograph courtesy of Iris Mitigation and Design.)

Although it is rare in riparian areas, when soil tests reveal that the area is excessively saline, choose species that have adapted to these conditions. Similarly, if herbivore predation has been demonstrated to be problematic, species can be chosen that are thorny or otherwise unpalatable. Grazing should also be limited during establishment with the use of enclosures.

### 4.1.3 Plant Selection for Wetland Areas

A wide variety of plant material is available for revegetating wetlands, as summarized in Table 13-5. Wetland and stream edge areas are generally revegetated with a combination of wetland seed mixtures, herbaceous wetland plugs, dormant woody cuttings and some potted woody plants. Ultimately, plant selection should be based on:

- Elevation of the planting area above normal water elevation (hydrology).
- Frequency of flooding.
- Permit requirements.
- Soil type.



**Photograph 13-4.** A Front Range creek restored with a gradient of vegetation types, including wetland plants. (Photograph courtesy of Iris Mitigation.)

Regardless of the plant material selected, several general principles should be considered to improve chances for success:

- The genetic source of the plant material may affect long-term revegetation success. Native woody nursery stock produced from locally collected plant materials, local dormant cuttings, and regional seed sources will be better adapted to local climatic conditions.
- Plant species should be chosen that closely match the existing environmental conditions, especially the hydrology.
- Some plant species may also be adapted to particular soil types (EPA 1994, Colorado Natural Areas Program 1998) and elevations.
- Only native species should be used.
- Common cattail (*Typha latifolia*) and reed canarygrass (*Phalaris arundinacea*) should not be seeded or planted in wetlands because they tend to be invasive.

Good reference sites with conditions similar to the project area are also a valuable tool in determining appropriate plant species, densities, distribution, abundance and diversity and should be considered when available.

## 4.2 Seeding

Guidance for permanent seed selection for each habitat type is provided below, followed by guidance for temporary seeding. Seed mix tables are provided in Appendix A. Local jurisdictions may require alternative seed mixes and/or require that the seed mix used for the project be approved prior to use.

### 4.2.1 Seeding Upland Areas

Seeding is the most common and least costly method of revegetation for upland areas. Seed is usually obtained from a commercial seed supplier. Grasses, forbs (wildflowers), and certain shrubs can all be seeded. Basic upland seed mixes are provided in Appendix A to this chapter. Wildflower species can be omitted if not available or another recommended wildflower seed can be increased. Seed mixtures provided in Appendix A are appropriate for most of the typical site conditions and can be mixed upon request by commercial seed companies. Pre-mixed “native” mixtures of grasses or wildflowers offered by seed companies can contain non-native aggressive and even weedy species which are not well suited to revegetation of regional upland areas. It is better to select a mixture provided in Appendix A which contains native species well suited to the task of providing erosion protection in this high plains area.

Fall is the preferred time for non-irrigated seeding. Late summer seedbed preparation followed by installation of the seed in the fall (October) allows winter months for additional firming of the seedbed before spring and germination. Fall seeding benefits from winter and spring moisture and usually assures maximum soil moisture availability for establishment.

Late winter to early spring (February to early April) is typically the next favorable time period for seeding. Winter and early spring seeding should not be conducted if the soil is frozen, snow covered, or wet (muddy). Although of greater risk, spring seeding (mid-April into early June) can be successful, especially during moist spring years. Mid- to late-summer seeding can be successful, with adequate precipitation and/or irrigation to wet and settle the seed bed. Firming of the seedbed following seeding will improve results during dry or warm seeding times.

### 4.2.2 Seeding Riparian Areas

Seeding is a good option for revegetating the herbaceous understory of a riparian plant community. Seeding timeframes for riparian areas are similar to those described for upland areas. Most native seed mixes (see Appendix A) are commercially available.

### 4.2.3 Seeding Wetland Areas

The least expensive wetland plant material is wetland seed (NRCS 1997). Often revegetation of wetlands is done through a combination of seeding and plugs which can add to the overall species diversity of a wetland and provides additional root structure and above-ground biomass (NRCS 2003). With proper seedbed preparation and use of blanket protection, UDFCD has observed a high rate of success.

### 4.2.4 Temporary Seeding

Temporary seeding is an erosion control best management practice (BMP) that prevents soil erosion on a construction site, soil stockpile, or other disturbed site prior to final site stabilization and helps to control weeds. Typically it is appropriate to utilize this practice when the disturbed area will not be finally prepared and seeded for a month or more (depending on local requirements).

The soil may be temporarily stabilized with sterile non-native annual or perennial grasses or native perennial grasses. The selected grass species for this temporary seeding, if non-native, should be either an annual grain or a sterile wheat/wheatgrass hybrid. Sterile grass will not re-seed and compete with more desirable native plantings. Annual grains should be selected depending on the time of year when they will be seeded. Oats, spring wheat, and spring barley are seeded in the spring, followed by millet from May through July. Winter wheat or winter barley may be seeded in the fall and winter months. These annual crop grasses allow for approximately 12 months of coverage. For a slightly longer period of

annual grass coverage, a sterile short-lived perennial wheat/wheatgrass hybrid may be seeded.

Perennial, faster-growing, native grasses can also be seeded as a cover crop. (See the Temporary Native Seed Mixes in Appendix A). However, non-native perennial grasses should never be seeded for temporary cover because they are difficult to eradicate later. Non-native perennial fast-growing grasses to avoid include smooth brome, timothy, orchard grass, crested wheatgrass, tall and meadow fescue, and intermediate wheatgrass.

See the Temporary Seeding Fact Sheet in Volume 3, Chapter 7, Construction BMPs for more information.

### **4.3 Trees and Shrubs**

#### **4.3.1 Upland Trees and Shrubs**

Table 13-6 summarizes native upland trees and shrubs that are generally appropriate for planting at an upland revegetation site. Containerized plants, bare root or B&B trees and shrubs can be used. A revegetation specialist must determine which of these native trees and shrubs are appropriate for the specific upland site. Each tree and shrub species listed requires different amounts of sunlight, soil condition and moisture in order to establish and thrive. Temporary irrigation is recommended for tree and shrub establishment.

#### **4.3.2 Riparian Trees and Shrubs**

The riparian ecosystem is a transition area between wetland and upland ecosystems and is dominated by large cottonwood (*Populus* spp.) and peachleaf willow (*Salix amygdaloides*) trees with an understory of willow (*Salix* spp.), other woody riparian shrubs, transitional area grasses and herbaceous species. The riparian vegetation has varying widths from the edge of the waterbody depending on factors including: geology, topography, elevation, soil type, hydrology, and upstream and upgradient build-out. Trees and shrubs depend on access to water but can handle occasional dry periods once established.

The cottonwood tree is a relatively short-lived species (80-100 years), and fallen cottonwood make excellent wildlife habitat. It is important to allow for cottonwood and willow regeneration in the riparian zone for replacement species. Cottonwood and willow will regenerate naturally in the riparian zone. The riparian vegetation provides flood control, nutrient cycling, stream food web support, pollutant filtering, sediment retention, and wildlife movement and migration corridors. Healthy riparian vegetation provides streambank stability and erosion control. However, vegetation in this zone can also reduce flood capacity when it's not managed. Non-native riparian species such as the crack willow (*Salix fragilis*) should be avoided as this fast growing and aggressive species has fragile branches which break off along with root mass and cause further erosion issues.

Table 13-7 provides a list of common Front Range native riparian trees and shrubs appropriate for the revegetation of riparian areas.

**Table 13-6. Upland trees and shrubs for revegetating sites on the Colorado front range**

<b>Upland Trees</b>	
<b>Common Name</b>	<b>Scientific Name</b>
Ponderosa pine <sup>1</sup>	<i>Pinus ponderosa</i>
Rocky Mountain juniper <sup>1</sup>	<i>Juniperus scopulorum</i>
Pinyon pine <sup>1</sup>	<i>Pinus edulis</i>
One-seeded juniper <sup>1</sup>	<i>Juniperus monosperma</i>
Hackberry <sup>1</sup>	<i>Celtis laevigata</i>
<b>Upland Shrubs</b>	
<b>Common Name</b>	<b>Scientific Name</b>
Big sagebrush	<i>Artemisia tridentata</i>
Yucca	<i>Yucca glauca</i>
Sand sagebrush	<i>Artemisia filifolia (sandy soils only)</i>
Fringe sagebrush	<i>Artemisia frigida</i>
Common juniper <sup>1</sup>	<i>Juniperus communis</i>
Winterfat	<i>Krascheninnikovia lantana</i>
Western sandcherry	<i>Prunus pumila</i>
Smooth sumac	<i>Rhus glabra</i>
Mountain mahogany <sup>1</sup>	<i>Cercocarpus montanus</i>
American plum	<i>Prunus americana</i>
Wax currant	<i>Ribes cereum</i>
Wood's rose	<i>Rosa woodsii</i>
Rabbitbrush	<i>Chrysothamnus nauseosus</i>
Threeleaf sumac	<i>Rhus trilobata</i>
Snowberry	<i>Symphoricarpos occidentalis</i>
Gambel oak <sup>1</sup>	<i>Quercus gambelii</i>
Fourwing saltbush	<i>Atriplex canescens</i>

<sup>1</sup> Temporary irrigation is recommended for establishment

**Table 13-7. Common Colorado front range native riparian trees and shrubs**

Common Name	Scientific Name	Plains	Foothills
<b>Riparian Trees</b>			
Aspen	<i>Populus tremuloides</i>		X
Boxelder	<i>Acer negundo</i>	X	X
Colorado blue spruce	<i>Picea coloradensis</i>		X
Narrowleaf cottonwood	<i>Populus angustifolia</i>	X	X
Plains cottonwood	<i>Populus deltoides</i>	X	X
Peachleaf willow	<i>Salix amygdaloides</i>	X	X
River birch	<i>Betula</i>		X
Rocky Mountain maple	<i>Acer glabrum</i>		X
Thinleaf alder	<i>Alnus incana</i>		
<b>Riparian Shrubs</b>			
American plum	<i>Prunus americana</i>	X	X
Bebb's willow	<i>Salix bebbiana</i>		X
Bluestem willow	<i>Salix irrorata</i>		X
Chokecherry	<i>Prunus virginiana</i>	X	X
Drummond's willow	<i>Salix drummondiana</i>		X
Geyer's willow	<i>Salix geyeriana</i>		X
Golden currant	<i>Ribes aureum</i>	X	X
Redosier dogwood	<i>Cornus sericea</i>	X	X
River hawthorne	<i>Crataegus rivularis</i>		X
Rocky Mountain willow	<i>Salix monticola</i>		X
Sandbar willow	<i>Salix exigua</i>	X	X
Skunkbush sumac	<i>Rhus triobata</i>	X	X
Snowberry	<i>Symphoricarpos occidentalis</i>	X	X
Wax currant	<i>Ribes cereum</i>	X	X
Wood's rose	<i>Rosa woodsii</i>	X	X

### 4.3.3 Wetland Tree and Shrub Plantings

Riparian woody plant materials (trees and shrubs) are also appropriate for planting around the edge of wetland areas. Seeding is generally not appropriate for revegetating trees and shrubs. If possible, woody plants that are pre-inoculated with mycorrhizal fungi, nitrogen-fixing bacteria, and/or other beneficial microbes should be requested (NRCS 2001). The following types of riparian woody plant material are commercially available for wetlands: B&B, plugs, bare root, and containers. Cuttings are the least expensive way to easily install riparian trees and shrubs and generally include cottonwoods (*Populus* spp.) and willows such as the sandbar willow (*Salix exigua*). Willows can be planted around the perimeter of wetland areas while riparian trees and most other riparian shrubs are planted adjacent to the wetland area but away from standing water so that the plants roots are not in fully inundated water conditions.

### 4.4 Types of Tree and Shrub Plant Material

Types of tree and shrub material include plugs, containers, B&B material, and cuttings.

#### 4.4.1 Plugs

Plugs, typically used for wetland revegetation and enhancement, are long, cylindrical or square planting tubes, measuring 22 in<sup>3</sup> or less, that contain stems, roots, underground perennial parts, and soil (Colorado Natural Areas Program 1998). Plugs are available for both herbaceous and woody plant species.

Wetland plugs may be obtained at a local wetland nursery. Determine availability early in the planning/design phase. Wetland plugs are sometimes grown specifically for a project so ordering them 6 months to a year in advance may be required. Revegetating wetlands with nursery-grown plugs has demonstrated a much higher establishment rate than with seeding or transplanted plants (NRCS 2003). In general, a project should purchase the largest plugs afforded by the budget (NRCS 2003). The plants should be free of injuries, wounds, or insect damage. The above-ground and underground material should have approximately the same density. Additionally, the roots should extend to the bottom of the tube but should not wind around the tube (i.e., not “root bound”). Figure 13-6 provides a detail for wetland plug planting.

#### 4.4.2 Containerized Material

Containerized plant material is typically grown from seed or cuttings at a nursery and is available in various container sizes, such as 4-inch, 6-inch, 1-gallon, 2-gallon, and 5-gallon pots. An advantage of using containerized stock is that it can be stored (under proper conditions) for a moderate period prior to installation.

When inspecting containerized material, look for well-proportioned above-ground plant material that is not excessively large or small for the container. Also, the roots should exhibit development throughout the soil but should not be growing through the bottom of the container or around the periphery of the container.

#### 4.4.3 Bare Root

Bare root plant material consists of the entire plant (upper plant parts and root systems) without a container or soil. These plants are typically dug up and sold when they are dormant and are commonly available for woody plant species. Because they are less hardy than containerized material, bare root plants tend to have a lower survival rate than containerized stock (Colorado Natural Areas Program 1998). However, they are also less expensive. Because bare root plants lack a container and soil, care should be taken to either install them immediately or carefully store them. In general, bare root seedlings should have a top length of at least 18 inches, a collar of at least 3/8 inch, and well developed terminal buds. The roots should also be well developed, should not be pruned, and should be highly fibrous (NRCS 1997).

#### 4.4.4 Balled and Burlapped

Balled and burlapped (B&B) trees and shrubs are grown in nurseries, dug out with the soil intact, wrapped in burlap, and tied with twine. Most plants sold as B&B are relatively large plants and may be cost prohibitive for some projects. When used, B&B trees may be planted in the upland transitional planting zone to achieve a forested component relatively quickly. The most important aspect to evaluate when inspecting a B&B plant is whether the root ball is moist and intact. If it is not intact or has dried out, the plant may not survive.

### 4.4.5 Cuttings

Live cuttings are a cost effective way to install woody riparian species such as cottonwood trees. When properly installed, the cuttings can establish readily. The costs for obtaining cuttings will consist primarily of labor costs associated with collecting, storing, and transporting the cuttings. Although inexpensive on a unit basis, costs per square foot can be somewhat high because cuttings are typically densely installed in large quantities. The overall success rates and low establishment costs lower the final cost per plant.

Collecting cuttings from the vicinity of the revegetation project allows for securing locally-adapted, native plant material. When possible, cuttings should be collected from areas that are similar to the area to be revegetated and be collected from multiple locations to provide genetic diversity (NRCS 2005b). It is important to make sure that the native stands used as donor sites are not destroyed by the collection.

Collect cuttings when dormant, preferable from late winter to early spring (prior to bud swell). In Colorado, the most successful time to collect cuttings is in early spring before the buds leaf out (usually between February 1st and April 15th). Cuttings may be classified as willow stakes, willow fascines, willow bundles, and cottonwood poles. Cuttings have varying diameters and lengths and can be grouped into bundles, fascines (wattles), brush layering, brush mattresses, etc. Cuttings are most often obtained from nurseries or from donor sites and are collected during the dormant season. In general, the larger the diameter of the cutting, the more successful it will be (Hoag 1995). Species most often used for cuttings along the Colorado Front Range include coyote or sandbar willow (*Salix exigua*) and plains cottonwood (*Populus deltoides* subsp. *monlifera*).

Table 13-8 presents a common classification system for cut woody plant material. Other classifications may also be found.

**Table 13-8. Classifications and typical sizes of woody plant material cuttings**

Classification	Size
Willow Stakes	24 to 30 inches long 0.5 to 1.0 inch diameter
Willow Fascines and Bundles	3 to 5 feet long 0.5 to 1.0 inch diameter
Cottonwood Poles	10 to 15 feet long 2 to 4 inch diameter

Although Table 13-8 specifies a range of lengths for willow cuttings and cottonwood poles, the final length of all cuttings will be determined by the depth to groundwater. In lower to middle terraces of riparian areas, the water table is expected to be relatively high. Consequently, cuttings do not need to be installed as deeply as in drier habitats. Regardless, cuttings should be installed to extend approximately 6 inches into the water table and should be tall enough to avoid shading by herbaceous vegetation (Hoag 1995). In general, willow species tend to be adapted to wetter environments than cottonwoods. Consequently, willows are commonly planted nearer to the streambanks and on the lower terraces, whereas cottonwoods are planted in slightly drier areas (higher middle to upper terraces). Planting holes for live stakes can be prepared using rebar and small sledge hammers, pry bars, or drills fitted with larger drill bits. Larger cottonwood poles can be planted using 4 to 8 foot augers. Allow time for the groundwater to fill the hole prior to installation, to ensure adequate depth for the cutting. The higher on the bank, the longer the cuttings will need to be.

All cuttings should be collected from insect-free and rot-free live woody vegetation. In general, collect green wood rather than older more mature wood (Hoag 1998). Do not collect cuttings with thick, cracked bark or suckers because they do not have the energy reserves necessary to consistently sprout. Collection guidance includes:

- **Willow Cuttings:** Live stakes should be cut with sharp pruning shears or a weed cutter with a saw blade near the ground surface to 10 inches above. Cuts must be clean, without stripping the bark or splitting the wood. The top should be cut straight across and the base cut should be cut at an angle. This will allow the cutting to be more easily installed and also differentiates the tip from the base. Another technique to help identify the correct ends of the cutting is to dip the upper part (angled end) in paraffin wax or another sealing substance (such as a non-toxic latex paint). For willow stakes and bundles, all side branches and leaves of a cutting should be trimmed. Branches should be left on cuttings for willow fascines. Live cuttings can be bound together with twine at the collection site for ease of handling and protection during transport.
- **Cottonwood Pole Cuttings:** Live poles should be pruned from live cottonwood trees at an approved harvest site. Cuts must be clean, without stripping the bark or splitting the wood. The best cottonwood pole cuttings are those from trees less than 18 inches in diameter. The base cut should be at a 45-degree angle and all the side branches trimmed off. The terminal bud (end of branch) must remain intact.

Immediately after cutting, all live stakes and poles should be carefully protected from desiccation by keeping the ends in water (tanks, buckets, or streams) at all times. During transportation, the cuttings should be placed in an orderly fashion in containers with water at least one foot deep and covered with tarp or burlap to prevent damage from the wind and to facilitate handling. If cuttings are collected in the late fall, they may be dry-stored in a cooler (kept at 29 to 34 degrees Fahrenheit) for up to 6 months (Hoag 1998). This should only be when necessary to extend dormancy. One method that may help initiate the growth process on the willow cuttings is to soak the bottom half of the cuttings in water for 2 to 7 days prior to installation (Hoag 1998).

#### 4.5 Wetland Sod/Rhizomes/Tubers

The least costly means for using existing wetland plant materials is to direct haul them in a wetland topsoil salvage operation. It is also possible to cut and transfer salvaged wetland plants. This plant material includes partial or entire plants, rhizomes, tubers, seeds, and sod mats. Salvaged plant material has the advantage of having local genetics and allowing the use of plant material that would otherwise be destroyed. These activities should take place only when the donor wetland (or portion thereof) will be destroyed as part of an activity permitted under a Section 404 permit.



**Photograph 13-5.** Installation of wetland sod along a reconstructed channel.

Wetland sod refers to large pieces of wetland plants and substrate that can be rolled up or placed flat for transport. Wetland sod should be collected from weed-free areas and ideally, should be collected when the soils are moist but well drained. A wetland sod mat is cut from a wetland with shovels and a front-end loader that is modified with a sharp-edged steel blade. The sections can then be placed on flat-bed trucks and transported to the wetland to be revegetated.

Commercially produced wetland sod grown in coir can be a cost effective means to reestablish protective shoreline wetland vegetation very quickly. Sod should be placed on the day of delivery to the site into the prepared planting locations with 1 to 2 inches of water to cover the roots of the vegetation in the coir. Cost for wetland sod is comparable to installing wetland plugs 12 inches on center. Wetland sod provides excellent erosion protection for the shoreline once staked in place. It requires anchoring except in backwater areas (see Figures 13-4 and 13-5). Check with commercial nurseries early to determine timeline of species and sod availability. Wetland sod is sometimes grown specifically for a project so ordering it six months to a year in advance may be required. If a donor site can be utilized, wetland plants can be harvested from an existing wetland at almost any time of the year (NRCS 2003). A rule of thumb for collecting herbaceous transplants from donor sites is to remove no more than 1-square-foot of plant material from a 4-square-foot area (NRCS 2003). This allows the remaining plants to rapidly fill in the harvest hole while still providing adequate transplant material. A depth of 5 to 6 inches of root and soil removal is adequate and will include beneficial organisms on the roots of the plants that will greatly aid the new wetland. At the new wetland site, the 1-square-foot transplant may be separated into four to five individual plants, depending on the species.

Rhizomes and tubers from existing remaining wetland areas may also be harvested. Rhizomes are underground stems that are capable of re-sprouting into new plants. Many bulrush species have large rhizomes containing a large amount of stored reserves. With significant stored reserves and local genetics, these large rhizomes tend to be more vigorous than relatively small nursery plugs. Many sedge species also have rhizomes. Rhizomes can be dug from donor sites and divided into sections that contain at least one viable growth point or node (NRCS 2003). Rhizomes should be collected in the spring before plants break dormancy and can be transplanted immediately or temporarily stored in sand or peat moss in a shaded, cool area.

Tubers may also be obtained from donor sites and occasionally from nurseries. Tubers are underground storage organs produced by some plants such as arrowhead (*Sagittaria* spp.), yellow pond lily (*Nuphar lutea*), and flatsedge (*Cyperus* spp.). Like rhizomes, tubers contain significant stored reserves and can be dug up from a donor site or purchased from a nursery and transplanted to a new wetland.

## 5.0 Plant Installation

Proper installation of plants is critical to successful revegetation. Installation methods depend on the type of plant material selected, as well as the habitat type. Installation methods generally include various seeding methods, installation of plug, containerized, B&B and bare root stock, and cuttings, as summarized in Table 13-9.

**Table 13-9. Installation methods for revegetating upland, riparian and wetland habitat types**

Revegetation Guidance Topic		Applicability to Habitat Type		
Installation Method	Chapter Section	Upland	Riparian	Wetland
Seeding (multiple methods)	5.1 & 5.2	✓	✓	✓
Herbaceous Plug, Containerized, B&B, and Bare Root Stock Installation	5.3	✓	✓	✓
Cutting Installation	5.4		✓	✓
Transplanting Wetland Plants (Wetland Sod, Rhizomes, Tubers)	5.5			✓

The most important consideration is placement. Install each individual plant in its favored microhabitat areas as well as in the appropriate planting zone for the habitat type (Figure 13-1). A revegetation specialist or wetland scientist should be present before and/or during planting to mark the installation locations for each plant (for example, using colored pin flags to represent each species).

Along the Colorado Front Range, the generally accepted planting window in upland and riparian areas for seeding, containerized tree and shrub stock, grass and herbaceous plug, and B&B plants is similar. The planting window for wetland plants is generally longer, given available hydrology and precipitation (NRCS 2003). Planting wetland plugs in the fall and winter can result in frost heave whereby the plug is pushed out of the ground. Spring planting can have slower initial growth but allows the plant to have a long establishment period before winter dormancy. Along the Colorado Front Range, the generally accepted planting window for upland, riparian, and wetland areas is summarized in Table 13-10. Irrigation will assist with plant establishment.

**Table 13-10. Planting/seeding schedule**

Type of Plant	Time to Plant/Seed
<b>Wetland and Riparian Species</b>	
Riparian Containerized Trees and Shrubs	Spring <sup>1</sup> /Summer/Fall <sup>1</sup>
Wetland and Riparian Grass and Herbaceous Plugs	Spring <sup>1</sup> /Summer/Fall
Wetland and Riparian Bare-root Plants	Spring <sup>1</sup> /Summer
Wetland Seeding	Spring <sup>1</sup> /Summer/Fall
Riparian Area Seeding	Spring <sup>1</sup> /Summer/Fall <sup>1</sup>
Willow Stakes	Late Fall/Winter/Early Spring <sup>1</sup>
Cottonwood Poles	Late Fall/Winter/Early Spring <sup>1</sup>
<b>Upland Species</b>	
Upland Containerized Trees and Shrubs	Winter/Spring <sup>1</sup> /Fall
Upland Grass and Herbaceous Plugs	Spring <sup>1</sup> /Summer/Fall
Upland Bare-root Plants	Spring <sup>1</sup> /Fall
Upland Seeding	Spring <sup>1</sup> /Summer/Fall <sup>1</sup>

<sup>1</sup>Preferred Season

## 5.1 Seeding Upland and Riparian Areas

Once the soil has been decompacted and amended based on the soil test and the seed bed has been adequately prepared, the site is ready for seed application. Seeding can be completed with a drill, broadcast spreader, or through hydroseeding (when allowed by the local jurisdiction). Interseeding may also be used in upland areas. (Seeding methods are described in Sections 5.1.1 through 5.1.4.) Seeding is best achieved on a roughened seed bed with soil clods no greater than 3 inches.

Seeding rates are determined by the method of seeding, selected grass species, and also the purity of the seed. Seed mixes should only be developed based on pure live seed (PLS) to account for species that have low germination rates or mixes that would otherwise have a high amount of inert material, including dirt or other plant parts. The seed tag from the supplier should be inspected before planting to ensure the seed mix is of high quality and contains the correct percentage of PLS.

To determine the pounds of seed per acre, determine the amount of seeds per square foot desired and the amount of seeds per pound of each species selected. A revegetation specialist can assist in determining the correct amount of seed per acre to be used on the site; however, local jurisdictions often specify seeding rates. On average, seeding rates for upland areas are approximately 18-25 lbs of seed per acre (or approximately 3,500,000 to 5,000,000 seeds per acre, depending on seed size).

Timing of seeding is an important aspect of the revegetation process. For upland and riparian areas on the Colorado Front Range, the suitable timing for seeding is from October through May (NRCS 2011b). The most favorable time to plant non-irrigated areas is during the fall, so that seed can take advantage of winter and spring moisture. Seed should not be planted if the soil is frozen, snow covered, or wet. Proper seeding time is dependent on adequate moisture for germination and seedling growth as well as adequate soil temperatures (Colorado Natural Areas Program 1998).

### 5.1.1 Drill Seeding

Drill seeding is the most commonly used mechanism for planting seed in the ground, if the site is large enough, has 3:1 slopes or flatter, and is not rocky. The seeding depth will vary based on seed selected but, on average, 1/4-inch to 1/2-inch seeding depth will suffice. Another method of determining seed depth is 2.5 times the width of the seed (NRCS 2011b). Seeding parallel to the contours of the site will reduce erosion caused by water flowing down drill furrows (Colorado Natural Areas Program 1998). Since the size and texture of seed for warm and cool season grasses differ, the drill seeder should have boxes for both warm and cool season seed applications or agitators for mixing the fluffy and smaller seeds (Colorado Natural Areas Program 1998). Warm season seed is usually fluffier than cool season seed and tends to get stuck in the box without the right type of agitator and picker wheel.

Native grass drills should also be equipped with Coulter wheels, adjustable depth bands, and drill row spacing of 7 inches or less. Drilling the seed in two directions perpendicular to one another will improve coverage and establishment. If seeded in only one direction, drilling should follow the contour to reduce a tendency for rilling down furrows. Partial broadcasting with some of the seed prior to or during drilling operations can also improve results, especially for finer seeded species.

### 5.1.2 Broadcast Seeding

Broadcast seeding consists of spreading the seed onto the surface of the soil by hand or with a hand spreader (also known as a belly grinder) or a mechanized rotary or cyclone seeder. Broadcast seeding may be cost effective in small areas and may be necessary in areas that are inaccessible to seeding equipment, such as rocky slopes, slopes steeper than 3:1, and areas without roads or other vehicular access.

Broadcast seeding is best completed after the ground has been raked or harrowed. This preparation will allow for better seed/soil contact than a hard-packed surface. Broadcast seeding is less reliable than drill seeding, so the seeding rate will need to be doubled or even tripled to achieve the recommended amount of seed at the desired depth. After seeding is complete, the seed should be raked or harrowed in to provide better seed to soil contact. After the seed has germinated, it may be necessary to spot-seed areas that did not establish. On-going spot seeding may be needed to revegetate bare areas.

Inaccessible small, steep, or soft seedbed areas may be broadcast seeded and harrowed or raked to cover the seed. Broadcast seeding rates of 35 to 45 pounds PLS per acre are adequate for most dryland broadcasting, depending on the plant species in the mix. To improve site diversity, hand-collected native seed can be broadcast before, during or after the main seeding operation. Stream edge seeding rates can be up to 50 to 60 pounds per acre to assure faster establishment or erosion protection.

### 5.1.3 Hydroseeding

Hydroseeding consists of a slurry of seed, fertilizer (if necessary), wood fiber mulch, water, and other additives (such as mycorrhizal fungi) that is blown onto the surface of an area to be seeded. It is mixed in a tank-mounted truck and is applied from the truck through long hoses. On steep slopes, a tackifier (a chemical compound that helps the material adhere to the slope) is often added. The term hydroseeding is sometimes mistakenly used interchangeably with the term hydromulching, which does not typically include seed.

The wood fiber mulch portion of the slurry is usually dyed to show which areas have been seeded. Hydroseeding provides for a single application of all additives, including seeds and mulch and can be used on steep slopes where it can help prevent erosion.

Hydroseeding is generally not recommended unless the slope is too steep to safely walk on (1.5:1) because it provides less soil to seed contact compared to other methods. If desirable, it may be used in flatter areas when the area is raked following hydroseeding. Some local jurisdictions do not allow hydroseeding due to low success rates on previous projects.

Hydroseeding is best achieved in three steps:

1. Soil preparation.
2. Application of the seed and water slurry. (The hydroseeder is constantly agitated so that the seed and water mixture is consistent.) Where site conditions permit, the seed should be raked into the soil.
3. Mulching.

#### **5.1.4 Interseeding**

Relatively weed-free sites with some residual native prairie species may be interseeded with a rangeland-type drill to minimize disturbance to existing grass cover. Interseeding directly into these areas without plowing or chiseling is preferable. A rangeland drill will cut furrows and place the seed at the proper depth. Weed seeds present on the site will be stimulated by interseeding and will probably result in additional annual weeds for a year or two after seeding. Mowing during establishment will help reduce competition from these weeds. Interseeding is an excellent way to enhance an existing upland field that has established vegetation but needs additional cover and possibly species diversity.

### **5.2 Seeding Wetland Areas**

Seeding wetlands can be successful in shoreline areas where the seed will be raked to cover and blanketed immediately. Seed will germinate on muddy surfaces but tends to float in standing water. Once seeded, germination should occur in a week or two.

Wetland plants establish best in fluctuating water conditions, such as those found in nature (NRCS 2003). Where possible, it may be beneficial to manipulate the water levels during establishment. Water can be lowered to expose at least some muddy surfaces so that floating seed will drift into muddy areas. The water level can remain low until muddy areas begin to dry, and then water can be returned to re-wet these surfaces, then drawn down again to allow further growth of the seedling plants. NRCS outlines a detailed hydrologic regime to stimulate wetland plant establishment in *Riparian/Wetland Project Information Series Number 22* (NRCS 2007).

Along the Colorado Front Range, the window for seeding wetland species is in the spring, summer, or fall, depending on hydrological conditions on the site.

### **5.3 Plug, Containerized, B&B, and Bare Root Stock Installation**

The density of plantings, especially when installing nursery stock, will greatly influence the overall cost of the project. In addition to the project's budget, careful consideration must be given to the character of the area to be revegetated when determining planting density. For riparian areas, use of cuttings (Section 5.4) may substantially lower the cost, allowing for higher planting densities.

#### **5.3.1 Wetland Plugs**

Wetland plugs should be planted 18 to 24 inches on center (NRCS 2003). Plantings at a wider spacing

exhibited less overall success, perhaps due to plant exposure. If the project budget does not allow 18- to 24-inch spacing, it is better to install plugs in patches at the proper spacing, separated by approximately 10 feet. Over time, plants will spread into the bare areas. As the hydrology within the cross-section changes and distance from the stream increases, species composition should change and spacing can widen to up to 2-3 feet depending upon erosion hazard and budget.

Each flat or rack of wetland plugs should come from the nursery clearly labeled by species. They should be wet upon transfer to the contractor and maintained with consistently moist soil in a shaded area until planted. This can sometimes be better accommodated at the contractor's yard than on site. Plugs delivered to the site should be planted the same day. When planting each plug, dig a generously-sized hole that allows the plug to be planted at the proper depth – not too shallow and not too deep. Avoid “J-rooting” the roots (bending into a “J” due to inadequate hole size). Also be sure to fill in air pockets near the roots to prevent the roots from drying out. Topping the surface of the plug with 1/2 to 2 inches of native soil can help to prevent desiccation. In areas where waterfowl grazing is possible, a 6- to 8-inch steel landscape staple can be used to secure each plant. Staples rust quickly and prevent the plants from being pulled up by the grazing birds.

### **5.3.2 Containerized, B&B, and Bare Root Stock**

Guidelines for planting container stock, B&B plants, and bare roots are similar to the guidelines for planting plugs, described above. As with plugs, be sure to keep the plants moist and cool in the shade at the site. Keeping the plant containers buried in damp wood chip mulch or placing them under a reflective blanket or shade cloth can also prevent desiccation (NRCS, 2001a). Check moisture frequently. If the container and plant are not large and the substrate is easily worked with (such as deep friable soils), the hole may be dug with a shovel. In contrast, if the plant is large and/or the substrate is rocky, planting hoes (hoedads) or small backhoes may be advantageous. Because B&B plants tend to be larger, special equipment may be necessary for their installation. A relatively large hole should be dug enabling the soils around the newly installed plant to be effectively tilled and loosened, providing a medium for the new roots to grow into. Each hole should be filled in soon after digging to prevent the soil from drying out, and the soil should be firmly tamped down around the new plant after the hole is filled. For additional details on tree and shrub planting, see Figures 13-7 through 13-13.

Do not pick up plants, especially trees, by the trunk or upper parts, but by the container. B&B plants should be carried by the root ball.

Seedlings, and especially tree saplings, that have been grown in a greenhouse are highly susceptible to both drought and freeze damage (NRCS 1997). These plants should be “hardened” for a few days prior to planting by placing them in an enclosure that is several degrees above freezing, and they should be watered only sparingly before planting. Because bare root nursery stock is dormant, no hardening is necessary prior to planting.

Each plant should be mulched and deeply watered soon after installation. In relatively dry areas, watering tubes or hydrogel packs can be installed with the plant to provide additional moisture after installation. These allow a temporary source of moisture to the new planting. Although container stock will be more resistant to desiccation during the planting process, bare root plants should be carefully protected from desiccation during the planting process. These can be kept in 5-gallon buckets of water until ready for planting.

### **5.4 Cutting Installation**

Cuttings are commonly installed in riparian and wetland areas. Installation guidance for each habitat type

is discussed separately below.

### 5.4.1 Installing Cuttings in Riparian Areas

Willows should be installed in the bank riparian planting zone where they can function to stabilize the bank. Cottonwoods should be planted in either the higher reaches of the overbank zone or the transitional zone (Figure 13-1). Regardless of the planting zone, cuttings need to be installed deep enough to contact groundwater year round. In areas with significant fluctuations in seasonal groundwater levels, cuttings will need to be installed deeper to ensure that they contact groundwater even during the driest season. Ideally, cuttings will be installed at least 6 inches into the lowest water table of the year with three to four buds above the ground surface (also includes the terminal bud on cottonwoods). Preferably, two-thirds (or at least half) of the length of the cutting should be in the ground (Hoag 1998). In areas with high erosion, cuttings should be installed 3 to 4 feet into the ground with the buds up.

Installing cuttings in riparian areas can be challenging depending on the substrate present. Cobbles can be impossible to auger, while holes dug in dry sands and gravels often collapse in on themselves (Los Lunas Plant Materials Center N.D.). Depending upon the substrate and the depth to groundwater, the following tools and equipment may be necessary to install cuttings: planting bars, augers, backhoes, rotary hammer drills, stingers, or post-hole diggers. The most important consideration when planting willow cuttings and cottonwood poles is to use equipment that will allow the cuttings to be planted at the depth that provides a constant water source (Hoag 1995). Additionally, the installation must result in good contact between the soil and the cutting.

Installation guidelines for willow stakes and bundles as well as cottonwood poles are provided within the details included in the chapter. Willow fascines can also be used, although UDFCD has observed this technique to be less successful than the above listed technics. For this reason a detail is not provided. See Hoag (2002) for installation guidance for willow fascines.

Recommended planting densities for cuttings include:

- When planting shrubby-type willows, such as coyote (sandbar) willows, a recommended planting density is 1 to 3 feet apart.
- When planting tree-type growth forms, such as cottonwoods and larger willows, a recommended planting density is 6 to 12 feet on center (Hoag 1998).
- If erosion is a concern in a portion of the project, plant shrubby-type willows 1 foot apart (Hoag 1998).

### 5.4.2 Installing Cuttings in Wetland Areas

Installing wetland shrubs such as sandbar willow within or adjacent to wetlands will most likely include the installation of willow cuttings, which may be installed individually or in bundles. If water erosion is anticipated, willow fascines, stakes, or the somewhat sturdier willow logs or biologs, may be installed along the water's edge. Regardless of the size or assemblage of the cuttings, they should be installed while dormant (after leaf abscission and before bud break), which extends from winter through early spring.

The equipment needed to install the cuttings will depend on the number of cuttings to be installed, size of the cuttings, and on the substrate they are to be placed in. A relatively low number of small cuttings can usually be installed with a planting bar. Larger cuttings, such as poles, may be installed with hand or

power augers. Wheel mounted augers on all-terrain vehicles can be extremely useful when planting thousands of cuttings. When planting in riprap or steep cut-banks, backhoes may be used. The most important consideration when planting cuttings of any size is to use the equipment that will allow the cuttings to be planted at the depth that provides a constant water source (Hoag 1995).

Cuttings should be installed to a depth that allows the end of the cutting to be in contact with groundwater throughout the growing season, even if the water table drops. Assessing groundwater depths prior to planting is highly recommended (Los Lunas N.D.). The basic technique to install a cutting, regardless of its size, is to auger or punch a hole into the substrate (to the appropriate depth) and then place the cutting in the hole. The soil should then be tamped down around the cutting to remove all air pockets. All cuttings, whether stakes or poles, should be planted with the buds pointed up and at least one healthy bud above the ground surface. Smaller cuttings should be installed to approximately three-quarters of their total length (NRCS 1997). In areas where the groundwater is relatively low (such as in adjacent upland or riparian areas), poles or posts may be installed 2 to 7 feet deep (Hoag 1995). For additional information on willow and cottonwood pole cuttings, see Section 4.4.4.

## 5.5 Transplanting Wetland Plants

Plugs, whole plants, rhizomes, and tubers salvaged from a donor wetland site are most easily transplanted when the site is slightly saturated. All plant material should be reinstalled in the same hydrologic zone that it was removed from. If 1-square-foot plugs are to be transplanted, they may be separated into smaller plantings. Use a small saw or shovel to chop them into smaller pieces (NRCS 2011). Both rhizomes and tubers should be placed in holes dug in the mud. Rhizomes should be planted just below the soil surface and tamped in to ensure good soil contact. Tubers should be placed in a hole that is approximately twice the size of the tuber (NRCS 1997). When transplanting shrubs or trees, the plant should be placed directly to the new location from the equipment used to dig it out. Ideally, a spade machine would be used to remove larger plants and would be sized to match the plants being removed (Colorado Natural Areas Program 1998). To avoid desiccation, trees and shrubs should be transplanted when dormant.

When donor topsoil is obtained from a wetland for its seed bank, it should be spread carefully over the new wetland at a thickness of 6 inches or less (NRCS 1997, Colorado Natural Areas Program 1998). Care should be taken to avoid damaging the plants and propagules that are present within the topsoil. The soils should be spread in the same hydrologic zone from which it was taken. Similarly, wetland sod that is obtained from a donor site should to be placed in the hydrologic zone matching the one from which it was taken. If several pieces of sod are available, they should be placed together in a bricklaying fashion on the soil surface and secured with wooden stakes (NRCS 2011). Gaps between the mats should be avoided to the extent practical.

## 6.0 Mulching

Mulching is the practice of applying a protective layer of material onto the soil surface of individually planted trees and shrubs or a broadly seeded area. Mulching is important in both upland and riparian areas but should not be conducted in wetland areas (EPA 1994). Mulching can be achieved through straw, hydromulch, or rolled erosion control product (RECP) installation. Applying mulch provides many benefits such as:

- Decreases germination of many weed seeds.
- Moderates soil temperatures.

- Retains soil moisture during dry weather (i.e., decrease evaporation).
- Increases infiltration.
- Decreases erosion.
- Adds organic matter to soil.
- Protects soil from “crusting” caused by raindrops on bare soil.
- Reduces compaction caused by heavy rains.

Mulching practices differ for individually planted trees and shrubs and seeded areas, as described below.

### 6.1 Mulching Individually Planted Trees and Shrubs

Individually planted trees and shrubs should be mulched immediately after planting. Mulch should be thickest at the edge of the planting saucer and taper to a zero depth at about one inch from the shrub/tree. Too much mulch can be smothering or produce excess moisture that could cause disease. Appropriate mulch includes straw, wood and bark chips, grass clippings, leaves, compost, wood and straw pellets, and inorganic material such as rock.

Mulching with wood and bark chips is less effective per unit weight than mulching with straw (NRCS 2005a). Additionally, it may discourage plant growth if applied at excessive rates. Wood and bark chips tend to have high carbon to nitrogen ratios. Additionally, nitrogen gets tied up during the breakdown of wood and bark making it less available for plants. This may actually provide a slight benefit for natives over weed species, which have higher nitrogen needs. A different form of wood and bark mulch is pellets. Wood and straw can be partially chemically digested and the “mash” formed into pellets. These pellets can be easily broadcast over a site (NRCS 2005a) but should not be used on slopes where they could readily slide downhill.



**Photograph 13-6.** Crimped straw mulch.  
(Photograph courtesy of David Chenowith.)

Although often overlooked, rock is excellent inorganic mulch (NRCS 2005a). It holds up well and doesn't float. The biggest constraints are its heavy weight and cost to transport. It may also require greater attention to weed control.

### 6.2 Mulching Seeded Areas

In seeded upland and riparian areas, one of the most important functions of mulching is to reduce erosion. Because riparian areas are often located on slopes draining into waterways, they are prone to erosion and may increase sediment loading to streams. Because upland seeded areas are often located on open dry areas, they establish better and more rapidly if mulched. Many materials are available for use as mulch on seeded areas, including but not limited to straw, wood and bark chips, grass clippings, leaves, compost, wood/straw pellets, blankets and netting, and inorganic materials such as rock. The more common materials are discussed below.

## 6.3 Types of Mulch

### 6.3.1 Straw Mulch

Straw mulch is the most widely used product for upland and riparian area seeding because it is cost-effective, readily available and conveniently packaged in bales. Straw mulch can be spread and crimped successfully on slopes of 4:1 or less. Steeper slopes may require a different type of mulch. Straw is fairly durable, easily applied, and provides excellent erosion protection.

Although straw includes the stalks of plants without the seed heads, some seeds may be present. Straw mulch containing weed seeds can drastically alter the success of revegetation on a site (Kruse et al. 2004). Using non-certified mulch may introduce noxious weeds and undesirable plant species onto the site. Additionally, many agencies require the use of certified weed-free mulch.

Long straw is appropriate for straw mulching but fragmented straw should be avoided. At least 50% of the straw mulch should be a minimum of 10 inches long for stability once crimped. The straw mulch can be applied by hand in small areas or by a chopper/spreader or blower in larger areas. The NRCS-recommended application rate is between 1000 to 8000 pounds of straw mulch per acre (NRCS 2005a). In general, the more straw used, the better the erosion protection. However, a high application rate may interfere with seedling emergence. A good rule of thumb when mulching over a seeded area is to mulch to a density where some soil is visible beneath the straw (between 2 to 2.5 tons of straw per acre is a recommended rate in Colorado).

The disadvantage of straw mulch is that it is highly susceptible to blowing away, so it must be anchored or crimped. The straw should be crimped into the soil to a depth of 2 to 3 inches with a crimping tool. The straw can also be anchored with a roller or empty drill (with heavy press wheels) pulled behind a tractor (NRCS 2005a). Disks and chisels should not be used to crimp because they will cut the straw, allowing it to blow free. If the slope is too steep for equipment access, a tackifier may be blown on top of the mulch by a hydromulching/hydroseeding truck. A tackifier should be applied at a rate of 150 pounds per acre. In cases where extra care is needed to avoid straw mulch blowing away, crimping and tackifier may both be utilized.

Because hay includes the entire plant including seed, mulching with hay will actually seed the site during mulching activities with non-native grass species and should be avoided. Alternatively, native grass species of hay may be purchased, but are difficult to find and expensive. Purchasing and utilizing a certified weed-free straw is an easier and less costly mulching method.

### 6.3.2 Rolled Erosion Control Products

Rolled Erosion Control Products (RECPs) include a variety of temporary or permanently installed manufactured products designed to control erosion and enhance vegetation establishment and survivability, particularly on slopes and in channels. For applications where natural vegetation alone will provide sufficient permanent erosion protection, temporary products such as netting, open weave textiles and a variety of erosion control blankets (ECBs) made of biodegradable natural materials (e.g., straw, jute, coconut) can be used. See the RECP fact sheet in Chapter 7, Construction BMPs, of Volume 3 for more information on appropriate uses and installation guidance for RECPs.

Although RECPs can be expensive, they are often the best approach for facilitating revegetation on steep slopes (such as 3:1 or steeper). For purposes of revegetation, it is best to avoid thick straw or excelsior blankets because they can impede grass establishment. RECPs must be installed correctly to be effective.

### 6.3.3 Hydromulch

Hydromulch is a slurry of water, wood fiber or recycled paper mulch, and an organic tackifier that is mixed in a large tank (mounted on a truck) and applied with a pump and hoses. It is a more expensive but can be an effective erosion control method that is used in areas where blowing loose straw may not be suitable (such as in established neighborhoods and along roadsides). Because the hydromulch holds the seed in place (with the tackifier), it is especially beneficial when applied to a slope that has been broadcast seeded (Goodwin et al. 2006). It is also valuable for stabilizing soil on steep slopes that cannot readily hold straw mulch. Hydromulch is a sterile product without weed seed concerns and should not be confused with hydroseeding, which combines seed with hydromulch.

Hydromulch should be specified to be “mechanically defibrated virgin wood fiber” and should be applied at a rate of 2000 to 3000 pounds per acre (NRCS 2005a). Approximately 2500 pounds of mulch and 150 pounds of organic psillium derived tackifier per acre is a recommended rate for Colorado. At the rate specified, 95% of the soil surface should appear covered after it dries. For every 500 pounds of wood fiber, 1000 gallons of water is needed. Accessibility to the site by the hydromulching truck and availability of water at the site, via a waterway (with water rights for the activity) or water truck, are essential. Because the hydromulch is applied through hoses, vehicular access throughout the entire site is not necessary provided that the hoses can reach all of the areas to be mulched. Always check installation rates, areas and quantities to be sure that the specified rate has been applied. Most failures result from low application rates.

#### RECP Recommendations

- UDFCD recommends only biodegradable RECPs because plastic netting products may trap snakes, deer and other wildlife.
- Heavy woven coconut fiber blankets (coir) are preferable on stream edges due to strength, flexibility and relative durability of the blanket.
- Coir, non-woven coconut blankets or biodegradable coconut straw composite blankets can be used in biologs and willow log construction.
- UDFCD uses coir mat placed over straw to hold topsoil and seed in place. See details located at the end of this chapter.
- Non-woven coconut blankets can be used on streambanks where less intense flows occur.
- Areas that are not as frequently inundated can use biodegradable coconut straw composite blankets. These blankets and straw blankets tend to be stiffer and not drape as well. Jute netting is soft and drapes very well, but is typically limited to a 4-foot width.

### 6.3.4 Compost

Compost is a mulch option that may be considered for use in upland and riparian areas. Compost consists of decomposed organic material and therefore has higher nutrient availability than other mulch materials (NRCS 2005a). This is a potential disadvantage in riparian areas where it could wash into waterways and impact downstream water quality. In contrast, in riparian areas where the topsoil has been completely removed, compost may be appropriate. On seeded upland and riparian areas, compost may also be a more costly mulching alternative because of the quantity required. However, in upland areas where the topsoil has been completely removed, compost may be a beneficial mulching alternative.

## 7.0 Maintenance

To achieve successful revegetation, the project's resources and budget must extend beyond the active construction phase to include maintenance for several years following construction. A maintenance and management plan should be completed for the site to include the following activities:

- Weed control and long-term management.
- Replanting dead trees and shrubs.
- Reseeding bare areas where grasses did not establish.
- Repairing ECB or other erosion control fabrics, if applicable.
- Stabilizing eroded areas, particularly following large storm events.
- Installing protection from animal damage.
- Temporary or permanent irrigation, as needed.
- Debris removal.
- Installing and/or repairing temporary fencing to control foot traffic, particularly in heavily used park areas.

Wetland areas have some additional unique maintenance requirements, which are discussed separately in Section 7.6.

### 7.1 Irrigation

When selection of plant species is based on the available moisture and soil conditions at a given site, the plants should thrive once established without the need for long-term irrigation. Temporary irrigation can be helpful for initial establishment, especially when seeding occurs in mid-summer or in a drought. In warmer urban settings, periodic supplemental irrigation can be helpful because heat from roads and buildings tends to warm and dry adjacent areas. Temporary irrigation of native species may not be necessary after initial watering, depending on the site and the hydrologic conditions during establishment.

When provided, temporary irrigation should be applied only during the plant establishment period, usually the first growing season. This is the period when seedling roots are near the surface and can benefit from occasional irrigation. Because frequent supplemental irrigation can encourage shallow rooting, irrigation should progress to less frequent and deeper (longer duration) irrigation (Table 13-11).

If irrigating from the adjacent stream, be sure to obtain water rights or do this during “free river” conditions. If water rights are not available, use a water truck.

Irrigation can occur through any of a combination of the following methods:

- Hand watering.
- Water truck.
- Water tubes or hydrogel packs (needs to be closely monitored and eventually removed).
- Drip system irrigation.
- Spray head irrigation.

The type of revegetation project may guide the type of irrigation necessary for the site. If, for example, the project is a U.S. Army Corps of Engineers 404 permit related project, longer-term permanent irrigation is not favored and should be avoided. (Irrigation is not allowed during the three to five year monitoring period for such projects.)

### **7.1.1 Seeded Area Irrigation**

Properly designed and installed seeded areas can be expected to germinate and establish with natural precipitation in average or wetter than average years. Even a single heavy precipitation event can be adequate to stimulate germination. If seeding is done during a drought season, or during the summer, some initial irrigation can assist with germination and establishment.

Monitoring of irrigation is a critical management activity that should occur if irrigation is to be used on a site. Either too much water or too little water can be detrimental to the survival of newly planted seedlings and plantings. Soil type will also influence the amount of irrigation needed since clay soils require less water to remain moist than do sandy soils. Moist soils in April encourage cool season native species to grow, whereas warm season grasses start to grow when soil is warmer with adequate moisture in mid to late May.

In order for native seed to germinate, the top 1 to 2 inches of soil should be moist, but not saturated. Initial irrigation should maintain moist soil in the seed bed, watering up to twice a day. Use of mulch or landscape fabric will reduce the frequency of irrigation required to maintain surface moisture. Once the grasses begin to establish, the roots will penetrate into the soil more deeply and irrigation should be reduced to three or four times a week, but for a longer duration, to allow for up to 6 inches of moisture in the soil. Irrigation should then be curtailed to one to two times per week later in the summer until the fall months when irrigation would cease to allow the plants to harden for the winter months. Table 13-11 provides a sample irrigation schedule for establishing native areas. Mulching/crimping/hydromulching seeded areas is also crucial to keep moisture in the soil.

Where an access road is available near the seeded area, a water truck can be used to spray-irrigate seeded areas on the same time basis as described above. The labor costs for using a water truck may eventually outweigh the costs of installing a more permanent irrigation system, depending on the site logistics.

**Table 13-11. Sample irrigation schedule for establishing native areas**

<b>Time Of Year</b>	<b>Frequency</b>	<b>Time of Day</b>	<b>Soil Moisture Depth</b>
Mid-April (Cool Season) Mid-May (Warm Season)	1-2 times per day until temperatures reach 80 degrees	Once in early morning once in late evening	Maintain soil moisture to 2-inch depth
Early June to July	Every other day or more if temperatures are above 90 degrees	Early morning or late evening	Maintain soil moisture to 6-inch depth Cycle and soak technique may be used to reach 4 inch-depth <sup>1</sup>
July to Mid-August	One application per week	Early morning or late evening	Maintain soil moisture to 6-inch depth
Mid-August to Mid-September	One application every other week	Early morning or late evening	Maintain soil moisture to 6-inch depth
Mid-September and on	Withhold watering to allow plants to harden for winter	NA	NA

<sup>1</sup> To maintain soil moisture in soils that are finer in texture, a cycle and soak technique of water application may need to be used. A cycle and soak technique is performed by watering in short durations, with multiple applications. This allows the water to infiltrate the soil rather than run off the site.

### 7.1.2 Tree and Shrub Irrigation

When properly located and planted, native trees and shrubs should be fairly self-sustaining with limited initial watering. Deep planting of trees and shrubs (which places the base of the root ball at the top of the ground water level, dormant season planting (before leaf out), and use of smaller nursery stock (which requires less water to establish) all can help reduce watering requirements for woody vegetation. All containerized plants should be well watered at installation time. When leafy plants are installed later in the spring or summer, a more prolonged irrigation program may be necessary.

Trees and shrubs should be deeply watered when first planted so that the entire root ball and soil around the root ball are inundated. Depending on the species selected, available soil moisture, and available precipitation, the trees and shrubs should be watered at least once a week during the first growing season. The need for a second growing season of irrigation can be monitored and assessed the following year. Monitoring the trees and shrubs is essential in order to be proactive with temporary irrigation before plants begin to stress and then die.

## 7.2 Replacing Dead Trees and Shrubs/Spot Reseeding of Bare Areas

Routine maintenance in establishing upland areas generally includes reseeded of bare areas and replacing dead, diseased, or dying planted trees and shrubs. At least some replacement of dying plants is typically required in riparian areas. If diversity is limited, additional species should be planted to add diversity to the establishing upland plant community. If a significant number of plants are diseased or infested by insects, a fungicide or insecticide application may be warranted.

In riparian areas, although newly establishing willows need relatively little maintenance, several maintenance activities will improve the riparian plant community's functions. As willows age, some may

need to be trimmed or cut down to stimulate smaller, denser growth (Hoag 1998). This should be completed in the dormant season. Similarly, on river floodplains no longer exposed to historic flooding (due to irrigation withdraws, dams, etc.), cottonwood and willow trees will no longer naturally replace themselves. These larger riparian species evolved to regenerate with natural cycles of intermittent flooding. When these cycles are disturbed, the larger riparian species are eventually replaced by a xeric plant community (Los Lunas Plant Materials Center 2005). Preserving these riparian plant communities will require ongoing planting and management.

In both riparian and upland areas, bare areas that were seeded will need to be weeded and spot-seeded/mulched annually until the bare areas fill in. In some cases, additional soil sampling and application of soil amendments in perpetual bare areas may be warranted. Irrigation concerns may need to be addressed in the bare areas until the grasses establish.

### 7.3 Vegetation Protection from Animal Predation

Additional maintenance often required for establishing upland and riparian plant communities includes replacing or installing fencing and protection to minimize animal damage. General browse protection can be provided by flexible tube tree protectors that trap moisture and protect the tree from browsing animals, wind desiccation, small rodents, and insects. They can be obtained in various thicknesses and heights. Rigid seedling protector tubes are plastic-like mesh tubes that protect young woody plants from browsing by larger animals. Metal deer fencing can also be installed around larger plantings to protect them from browse by deer. Deer may also be discouraged by bud caps (pieces of paper that hide buds from deer). Where voles are a concern, wrap the base of the planted tree twice with 6- to 8-inch-wide strips of tinfoil. This can be effective for up to two years (NRCS 2001a).

When in an area heavily populated by prairie dogs, it is not always realistic to keep all prairie dogs out of the newly planted area. Use a perimeter fence to deter prairie dogs from entering the area of construction and consider a more permanent fence during the time of plant establishment. This can be constructed using a wire mesh that is buried 3 feet into the ground and extends above ground 3 feet. Alternatively, the buried portion of the fence could be placed horizontally and just buried a couple inches (in an “L” formation). Attach silt fence onto the upper portion to limit visibility to the protected area. This fence will require maintenance and



**Photograph 13-7.** Prairie dogs will attempt to dig under the fence. Bury the wire mesh portion vertically (shown) or in the form of an “L” to deter prairie dogs from burrowing under the fence.

should remain in place for 1 to 2 years. Fumigation may also be beneficial during this time.

If beavers are a concern, new plantings can be protected by 5-foot-high wire tree guards. This should be done with the understanding that the beaver will look for other (mature) trees. Unlike prairie dogs, when the project requires removal of beaver (although rare), there are typically landowners that will accept them. An experienced trapper can live-trap and safely relocate beaver to a new location.

Geese can cause significant damage to a newly planted wetland. Waterfowl may mouth the plants looking for seed and uproot the planted material. Wetlands often need waterfowl predator control through the placement of a grid of T-posts installed 10 foot on center with wire strung between the posts (see Figure 13-16). Brightly colored flagging is then tied onto the wire. This grid of predator control will

reduce waterfowl landing in the newly planted area. Alternatively a 6- to 8-inch steel landscape staple can be used to secure each seedling. Staples rust quickly and prevent the plants from being pulled up by the grazing birds.

#### **7.4 Weed Management**

Control of weeds, especially noxious weeds, is a critical component of maintaining establishing upland and riparian areas. Any weeds on the Colorado Noxious Weed “A List” should be promptly and aggressively treated. Similarly, areas with infestations of Colorado Noxious Weed “B or C List” species with more than 10% cover should be promptly addressed; however, a tolerable range of what species can be present and/or the cover of an individual species can vary by state or local jurisdiction and by specific permitting requirements for an individual project. Using GPS to mark the locations of noxious weeds may be beneficial for both short and long-term management. Developing an integrated weed management plan is highly recommended for most newly revegetated sites. Integrated weed management is defined as using a variety of techniques to control weeds (Colorado Natural Areas Program 1998). Techniques that may be used include mowing, herbicide application, rotational grazing, biocontrol, and hand-removal or cutting. The integrated weed management plan should evaluate the weed species found at the site and determine the best combination of control strategies for each species. Note that newly seeded plants will be especially vulnerable to all herbicides; therefore, herbicides should not be applied to newly-seeded areas until the plants are relatively hardy [when the plants have four to six blades (Goodwin et al. 2006)]. Following the initial years of intensive management, a long-term commitment for spot-spraying of re-sprouting weeds must be part of any control plan. The herbicide label should be read to determine when to re-seed because the time an herbicide remains active in the ground differs for each herbicide.

Newly seeded areas can be very weedy during the first year of growth. Annual weed seeds are abundant in most topsoil and germinate readily. It is critical that annual weeds be mowed when they are in flower and before they produce seeds. Two or three mowing operations in the first year of growth can generally address most of the annual weeds on a site. UDFCD has also found that starting weed control one to two years prior to construction can be beneficial in controlling new weeds following seeding. Biennial and perennial weeds can be spot-treated by a certified weed control specialist with approved herbicides by mid-summer or when the seeded grasses have three to four leaves. A boom sprayer should not be used during the first summer after seeding.

Weed control of established seeded areas during the second growing season may involve a combination of techniques including spot spraying weedy areas. However, herbicide applications should be closely managed and herbicide selection, method of application, times and rates should be chosen carefully and recorded based on the type and amount of weeds present. A certified applicator should be used for all herbicide applications. A copy of their applicator license should be obtained and records should be kept of all applications that occur on the site. A Compliance Certification for the CDPS General Permit for Discharges from Application of Pesticides may be required for herbicide applications exceeding certain thresholds.

A seeded area without shrubs may be mowed during the first year of establishment as a good early weed control method. Weedy areas should be mowed 6 to 8 inches when they exceed 12 inches in height or just begin to produce seed. A small or tandem wheeled tractor is appropriate for this type of mowing. Mowing should not be used to limit plant height. A low-growing grass seed mix should be used if shorter grasses are desired. The normal mowing height for established grasses should be no less than 6 inches because mowing too low is detrimental to grass establishment.

Additional natural weed control methods have a variety of levels of success depending on the species of weed. These include goat/sheep temporary grazing, insect releases, rotational grazing, hand

cutting/pulling, spot seeding, and other natural methods. These methods can be integrated with herbicide treatments and mowing for best results. Spot seeding bare areas with desirable grass and/or planted species once weeds are controlled is highly encouraged so that the bare areas do not become established with additional weedy species.

## 7.5 Managing Erosion in Riparian Areas

Riparian areas commonly require maintenance to address erosion. The site should be inspected closely for signs of erosion. If necessary, install additional erosion control measures such as erosion control blankets or consider the need for other bioengineered solutions (see the Bioengineered Channels section of the *Major Drainage* Chapter for further detail on bioengineered bank stabilization methods). Existing erosion control matting, netting, or blankets should be repaired or replaced as required and in areas where it is still needed. In locations where major erosion is occurring and cannot be controlled with bioengineering techniques, other types of engineered structural measures may be necessary.

## 7.6 Maintenance for Created, Restored and Enhanced Wetland Areas

A maintenance plan should be part of the wetland creation, restoration and enhancement project. A maintenance plan should include periodic observations of the wetland area during the growing season to observe existing hydrological conditions, wetland establishment, weed control, spot revegetation and other maintenance needs at the site.

During the maintenance visit, it is important to observe and document existing hydrologic conditions for wetland establishment as designed. Hydrologic observations should include these conditions:

- Standing water.
- Subsurface water through digging of soil pits.
- Observation of established wetland vegetation.

If wetland plants are not fully established, but adequate hydrologic conditions exist, one can assume that the plants will eventually establish throughout the area. Additionally, in areas where water control is possible, wetland plant growth can be stimulated by alternating flooding and drawdown in the wetland. If wetland plants are not establishing and there is a lack of adequate hydrologic conditions, additional excavations, water diversion, or grading may be warranted. If the water depths are too deep for wetland plant establishment, additional fill, water diversion, water pumping, or outlet reconfiguration may be warranted. Once appropriate hydrological conditions have been achieved, additional spot seeding/planting of wetland plant material may be necessary.

A weed management plan is an important part of wetland area design before the seeding/planting occurs. Observation and documentation of weedy species establishing in and around the wetland area is an important first step in weed control. Weeds are controlled through the following actions:

- Applying EPA-approved aquatic herbicides (application at the correct time of year for the targeted weed).
- Hand-pulling of weed species.
- Hand mowing or weed cutter (avoid large vehicles that will damage vegetation).
- Using biological controls (insects other natural control).

- Coordination of weed control planning with adjacent property managers.
- Additional spot seeding/planting of wetland plants may be needed to fill in areas where volunteer weed species may again become established.

Other maintenance activities should include:

- Flood debris (natural and human origin) can create a smothering buildup in riparian wetland areas. If left for long periods of time, it will encourage invasion by weeds from seeds carried by the high water. Sediment deposits on newly seeded areas can sometimes be raked or shoveled off in the first few days following a flood to allow recovery of the young vegetation. If the sediments are deep, they may require additional seeding and possibly mulching. Seed mixtures can be selected based on the texture of the flood-deposited sediment. Biweekly to monthly inspection and removal should continue throughout establishment when regular flows are anticipated (April through September).
- Planted woody trees and shrubs should be observed and documented for wildlife damage such as browse, trunk damage and other physical damage. If wildlife damage is observed, protection should be installed.
- Beaver protection installed at the time of installation may require straightening and debris removal after high water event. Over the long-term, beaver cages will require loosening or enlarging around growing trees to prevent loss of the trees from strangulation by the fencing.
- Irrigation of seeded/planted material during the early establishment period may be needed during especially hot summer drought periods.
- Social walking/biking trails through wetland areas should be discouraged through piling dead wood, boulders, and/or appropriate signage.
- Repair perimeter fencing, signage, and vandalism that may occur.

## 8.0 Post-construction Monitoring

Post-construction monitoring of revegetation progress is essential for determining the appropriate maintenance and corrective measures that may be required during establishment of vegetation at a site. The results of the monitoring provide the information necessary for adaptive management, which is key for effective revegetation due to climatic variability and other uncontrollable factors. Research has shown that if a revegetation project has problems, they typically show up in the first couple of years after plant installation (NRCS 1997).

A trained professional should conduct and evaluate monitoring recognizing that the site will progress through intermediate stages prior to full revegetation. A variety of techniques and methods for assessing revegetation are available, ranging from simple photo documentation, to comparison to reference sites, to more rigorous ecological evaluations, particularly for wetland sites. See BLM (1999) and Faber-Langendoen et al. (2006) as two resources for monitoring approaches at revegetation sites.

For upland and riparian areas, post-construction monitoring may be required from a federal, state, or local agency depending on project permits. If monitoring is required, the agency may have specific success criteria to meet. For wetland areas, post-construction monitoring is usually required as a condition of the Clean Water Act Section 404 permitting process. A permit granted by the USACE authorizing fill in wetlands or other waters typically specifies a series of performance measures (also referred to as success criteria or performance criteria) that the mitigation area must meet in order for the permit conditions to be

met.

Because of the importance of monitoring, adequate funding must be set aside during project development to support this phase of the project. Otherwise, the project may fail to comply with permit conditions (particularly 404 and stormwater construction permits, which require follow-up monitoring and reporting) and/or failure on-the-ground through lack of appropriate adaptive management.

The following post-construction monitoring phases are typical:

- **Warranty Period Monitoring:** Warranty period monitoring of sites with substantial completion by early spring should begin in late May or early June to determine initial seedling establishment and composition and density of weed species. Monitoring in May can help determine a variety of conditions: whether seedling establishment is proceeding; whether the specified seed mix was in fact installed correctly at the proper rate; what the weed species are and when they are likely to require early summer mowing or later spot herbicide treatment; whether the bank protection measures are holding and establishing woody and herbaceous growth; whether the woody containerized vegetation appears to be healthy or in need of watering; and whether the trees and shrubs which were planted still appear to be the proper species as they leaf out. Evaluation of establishment at this time can sometimes lead to early corrective measures, such as reseeded of bare areas or rilling, mending or correcting poorly installed RECPs. Early growth of noxious biennial species which will flower in June or July should be noted and weed control efforts planned at this time.

A second key warranty monitoring period typically occurs in August, when the area can again be checked for continued successful herbaceous establishment, woody vegetation survival and growth, and whether occasional watering and weed control efforts are being made. Plans can be made at this time for late season mowing and spot herbicide treatments, fall re-seeding and other corrective measures.

Final warranty period inspection should occur at the end of warranty (1 year after substantial completion of construction and planting). At this time the site should be evaluated to determine if establishment meets the contract specification and plans. All temporary erosion control fencing, straw bales, tree protection or other temporary protective measures should be removed and disposed of offsite. Bare areas should be seeded with the seed mixture specified for that area in the plans.

- **Long-term Monitoring:** The next phase includes longer-term monitoring, typically by a revegetation specialist or wetland scientist with reporting to regulatory authorities. Monitoring methodologies may range from a quick visual inspection to an in-depth study of species composition, distribution, and density based on quantitative sampling techniques (Colorado Natural Areas Program 1998).

#### **Should the contractor be responsible for the success of the vegetation?**

Warranties are typically used to hold the original contractor responsible for the ultimate success of the vegetation. However, this is not necessarily the best or even the most cost effective method to ensure success. UDFCD will typically have the contractor perform initial efforts to vegetate the disturbed area. If these efforts turn out to be unsuccessful, UDFCD will work directly with a landscape specialist/contractor in an effort to reach adequate coverage of vegetation as quickly as possible.

Representative issues that may need to be addressed during the course of post-construction monitoring include:

- Noxious weeds—weeds on the Colorado Noxious Weed A List should be noted and promptly and aggressively treated. Similarly, areas with infestations of Colorado Noxious Weed B or C List species with more than 10% cover should be promptly addressed; however, a tolerable range of what species can be present and/or the cover of an individual species can vary by state or local jurisdiction and by specific permitting requirements for an individual project. Using GPS to mark the locations of noxious weeds may be beneficial for short- and long-term monitoring.
- Browse damage (i.e., impacts from animals grazing on plants).
- Streambank or shoreline erosion.
- Irrigation needs or adjustments (irrigation is typically not needed for long-term maintenance of native areas).
- Replacement plantings.
- Water management in wetlands (if feasible).
- Removal of previously installed browse protection or temporary irrigation.

If animal damage or weed infestations appear to be significant issues, management plans can be prepared to address the problems over the long term.

## 9.0 Conclusion

Successful revegetation requires a multi-phase effort targeted to the relevant habitat condition. Drainage projects along the Front Range may encounter upland, riparian, and wetland habitat types, each having unique revegetation considerations. Successful revegetation projects will address proper site preparation, plant material selection and installation, mulching, maintenance and post-construction monitoring. Early involvement of a revegetation specialist can help improve the likelihood of a successful revegetation effort. Additionally, post-construction monitoring can help to identify problems that can be corrected while they are at a more manageable stage.

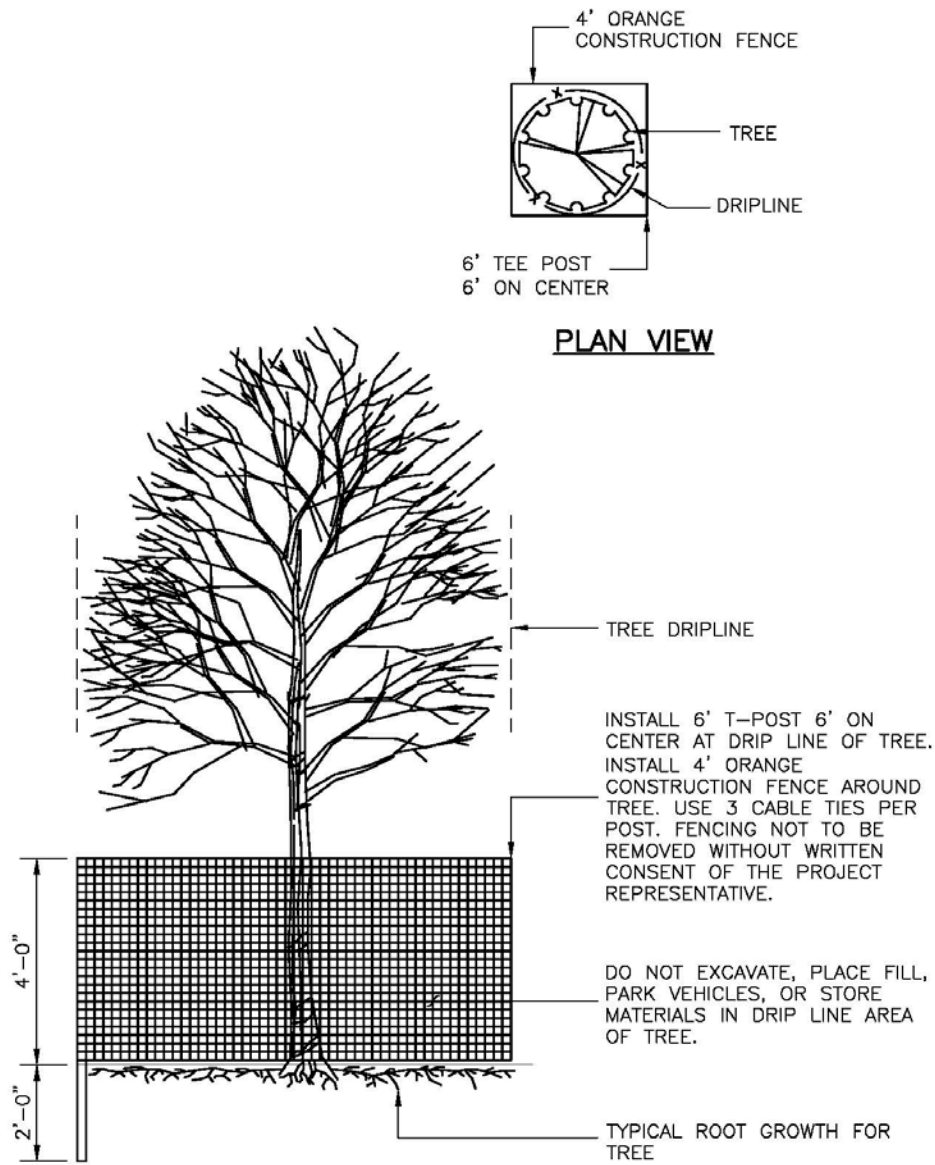
## 10.0 References

- Bantilan-Smith, M., Bruland, G., MacKenzie, R., Henry, A., and C. Ryder. 2009. A Comparison of the Vegetation and Soils of Natural, Restored, and Created Coastal Lowland Wetlands in Hawaii *Wetlands*, 29 (3): 1023-1035. DOI: 10.1672/08-127.1
- Brown, S.C. and B.L. Bedford. 1997. Restoration of wetland vegetation with transplanted wetland soil: An experimental study. *Wetlands*, 17 (3): 424-437.
- Burton, T.A., Smith S.J., and E.R. Cowley. 2008. Monitoring Stream Channels and Riparian Vegetation – Multiple Indicators, Ver. 5.0. April. Interagency Technical Bulletin BLM/ID/GI-08/001+1150, ID.
- Cardon, G.E., J.G. Davis, T.A. Bauder, and R.M. Waskom. 2007. Managing Saline Soils. Colorado State University Extension Paper No. 0.503. ([www.ext.colostate.edu/pubs/crops/00503.html](http://www.ext.colostate.edu/pubs/crops/00503.html)). Ft. Collins, CO: Colorado State University Extension.
- Colorado Natural Areas Program. 1998. Native Plant Revegetation Guide for Colorado. Caring for the Land Series, Vol. 3. October. Colorado State Parks, Colorado Department of Natural Resources, Denver, CO.
- Colorado State University Extension. 2011. Estimating Soil Texture: Sand, Silt or Clayey. December. Colorado State University Extension. Fort Collins, CO.
- Dickinson, S.B. 2007. Influences of Soil Amendments and Microtopography on Vegetation at a Created Tidal Freshwater Swamp in Southeastern Virginia. Thesis. August 31. Virginia Polytechnic Institute and State University, Blacksburg, VA.
- Dorner, J. 2002. *An Introduction to Using Native Plants in Restoration Projects*. Center for Urban Horticulture, University of Washington. Prepared for U.S. Department of the Interior and U.S. Environmental Protection Agency. Washington, D.C. November.
- Elzinga, C.L., Salzer, D.W., and J.W. Willoughby. 1998. Measuring and Monitoring Plant Populations. BLM Technical Reference 1730-1. Denver, CO.
- Faber-Langendoen, D.J., Rocchio, M., Schafale, C., Nordman, M., Pyne, J., Teague, T., Foti, and P. Comer. 2006. Ecological Integrity Assessment and Performance Measures for Wetland Mitigation. NatureServe, Arlington, VA.
- Farardo, G.I. 2006. Physical and Chemical Soil Properties of Ten Virginia Department of Transportation Mitigation Wetlands. Thesis. Virginia Polytechnic Institute and State University, Blacksburg, VA.
- Goodwin, K., Marks, G., and R. Sheley. 2006. Revegetation Guidelines for Western Montana: Considering Invasive Weeds. Prepared for the Missoula County Weed District with funding assistance from the Center for Invasive Plant Management and the Montana Noxious Weed Trust Fund. Missoula, MT.
- GreenCO. 2008. *Green Industry Best Management Practices (BMP) Manual for the Protection and Conservation of Water Resources in Colorado*. Prepared by Wright Water Engineers.
- Harris, J.A. and P. Birch. 1989. Soil microbial activity in opencast coal mine restorations. *Soil Use and Management* 5 (4): 155-160.

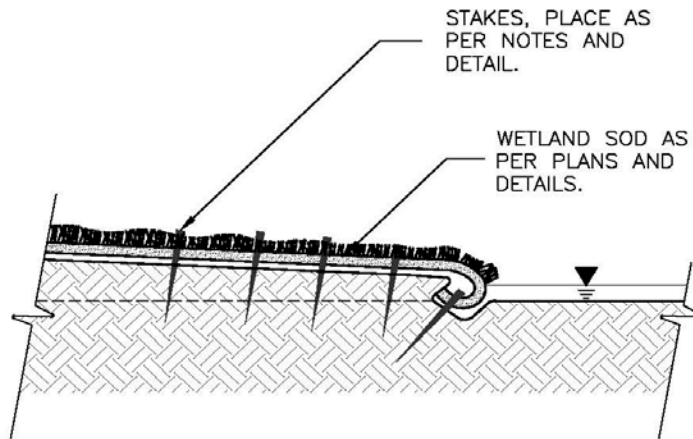
- Hoag, J.C. 1995. Using Dormant Pole Cuttings to Revegetate Riparian Areas. Interagency Riparian/Wetland Plant Development Project, USDA-Natural Resources Conservation Service, Aberdeen, ID. July.
- Hoag, J.C. 1998. Establishment Techniques for Woody Vegetation in Riparian Zones of the Arid and Semi-arid West. Natural Resources Conservation Service. Plant Materials Center, Aberdeen, ID.
- Hoag, J.C. 2002. Streambank Soil Bioengineering Field Guide for Low Precipitation Areas. USDA-Natural Resources Conservation Service, Aberdeen, ID.
- Hoag, J.C. 2007. How to Plant Willows and Cottonwoods for Riparian Restoration. USDA-Natural Resources Conservation Service, Aberdeen, ID.
- Kruse, R., Bend E., and Bierzychudek P. 2004. Native Plant Regeneration and Introduction of Non-Natives Following Post-fire Rehabilitation with Straw Mulch and Barley Seeding. Elsevier *Forest Ecology and Management Journal*, 196 (299-310). March.
- Los Lunas Plant Materials Center. 2005. Plant Materials Technical Note No. 67: Riparian Restoration in the Southwest: Focusing Your Planning on Crucial Factors Concerning Site Preparation, Landscape Goals, and Revegetation. February. Natural Resources Conservation Service, Albuquerque, NM.
- Los Lunas Plant Materials Center. No Date. Guidelines for Planting Dormant Pole Cuttings in Riparian Areas of the Southwest.
- Natural Resources Conservation Service. 1997. Wetland Restoration and Enhancement, Northwest Freshwater Wetlands Student Workbook. National Employee Development Center, U.S. Department of Agriculture. January.
- Natural Resource Conservation Service. 1998. Soil Quality Resource Concerns: Soil Biodiversity. U.S. Department of Agriculture. Washington, D.C. January.
- Natural Resources Conservation Service. 2001a. Plant Materials Technical Note No. 3. Tips for Planting Trees and Shrubs: Revegetation and Landscaping. February. U.S. Department of Agriculture, Portland, OR.
- Natural Resources Conservation Service. 2001b. Riparian/Wetland Project Information Series No. 16: Riparian Planting Zones in the Intermountain West. U.S. Department of Agriculture. (Revised, March).
- Natural Resources Conservation Service. 2002. Technical Note Plant Materials No. 59: Plant Suitability and Seeding Rates for Conservation Plantings in Colorado. September. U.S. Department of Agriculture, Denver, CO.
- Natural Resources Conservation Service. 2003. Technical Note Plant Materials No. 13: Harvesting, Propagating, and Planting Wetland Plants. December. U.S. Department of Agriculture, Boise, ID.
- Natural Resources Conservation Service. 2005a. Mulches and Mulching for Erosion Control. February. U.S. Department of Agriculture.
- Natural Resources Conservation Service. 2005b. Riparian/Wetland Project Information Series No. 18: Streambank Soil Bioengineering Considerations for Semi-Arid Climates. May. U.S. Department of Agriculture.

- Natural Resources Conservation Service. 2006. Technical Note Plant Materials No. 38: Suggestions for Installing Hardwood Cuttings (Slips, Whips, Live Stakes, Poles, Posts) and Live Fascines (Pacific Northwest Region, West of Cascades). September. U.S. Department of Agriculture, Portland, OR.
- Natural Resources Conservation Service. 2007. Riparian/Wetland Project Information Series No. 22: How to Manipulate Water in a New, Restored, or Enhanced Wetland to Encourage Wetland Plant Establishment. June. U.S. Department of Agriculture, Aberdeen, ID.
- Natural Resources Conservation Service. 2008. *Engineering Field Handbook*, Chapter 13: Wetland Restoration, Enhancement, or Creation. April. U.S. Department of Agriculture.
- Natural Resources Conservation Service. 2011a. Technical Note Plant Materials No. 38: Description, Propagation, and Establishment of Wetland – Riparian Grass and Grass-like Species in the Intermountain West. October. U.S. Department of Agriculture, Boise, ID – Salt Lake City, UT.
- Natural Resources Conservation Service. September 2011b. Technical Note Plant Materials No. 74: Seedbed Preparation for Conservation Plantings. U.S. Department of Agriculture, Denver, CO.
- Natural Resources Conservation Service. No Date. Backyard Conservation Tip Sheet: Mulching. Retrieved on April 27, 2012 from:  
[http://www.nrcs.usda.gov/wps/portal/nrcs/detail/national/newsroom/features/?&cid=nrcs143\\_023585](http://www.nrcs.usda.gov/wps/portal/nrcs/detail/national/newsroom/features/?&cid=nrcs143_023585)
- Natural Resources Conservation Service. No Date. Basic Guide for Seeding Native Grass in Arid and Semi-Arid Ecoregions. U.S. Department of Agriculture, Los Lunas, NM.
- Oregon Department of State Lands (ODSL). 2009. Routine Monitoring Guidance for Vegetation, Interim Review Draft, Version 1.0. September 23. State of Oregon, Salem, OR.
- Stankey, G.H., Clark, R.N., and B.T. Bormann. 2005. Adaptive Management of Natural Resources: Theory, Concepts, and Management Institutions. Gen. Tech. Rep. PNW-GTR-654. August. Portland, OR: U.S. Department of Agriculture, Forest Service, Pacific Northwest Research Station. 73 p.
- State of Colorado. Water Quality Certification Requirements - Fulfilling the Requirements of the Clean Water Act Section 401. Colorado Department of Public Health and Environment. Denver, CO.
- Strohmayr, P. 1999. Soil Stockpiling for Reclamation and Restoration activities after Mining and Construction, *Restoration and Reclamation Review*, University of Minnesota, Vol. 4, No. 7, Spring. <http://conservancy.umn.edu/bitstream/59360/1/4.7.Strohmayr.pdf>
- Swift, C. 1997. Salt Tolerances of Various Temperate Zone Ornamental Plants, Colorado State University Tri-River Area.
- Swift, C. and A. Koski. 2007. Growing Turf on Salt-Affected Sites. Gardening Fact Sheet 7.227 (www.ext.colostate.edu/pubs/garden/07227). Ft. Collins, CO: Colorado State University Extension.
- U.S. Bureau of Land Management (BLM). 1999. Sampling Vegetation Attributes, Technical Reference 1734-4, U.S. Department of Agriculture. Denver, CO.
- U.S. Environmental Protection Agency (EPA). January 1994. A Citizen's Guide to Wetland Restoration. Approaches to Restoring Vegetation Communities and Wildlife habitat Structure in Freshwater Wetland Systems. Region 10, Seattle, WA.

- Vallentine, J.F. 1989. *Range Development and Improvements*, Third Edition. Academic Press, Inc. San Diego, CA.
- Weed Research and Information Center, University of California-Davis. 2013. *Weed Control in Natural Areas in the Western United States*.
- West, N.E. 1985. Shortcomings of plant frequency-based methods for range condition and trend. William C. Krueger, Chairman. Proc., 38th Annual Meeting Society of Range Management. February 1985. Salt Lake City Society for Range Management 87-90.
- Zedler, J.B. and M.W. Weller. 1989. Overview and Future Directions. In: J.A. Kusler and M.E. Kentula, eds. *Wetland Creation and Restoration: the Status of the Science*, Vol. 1. U.S. EPA/7600/389/038, pp. 465-473. U.S. Environmental Protection Agency, Corvallis, OR.



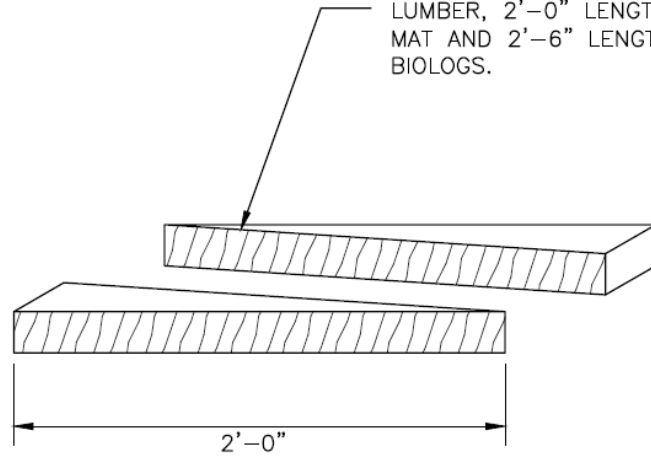
**Figure 13-3. Tree protection**

**NOTES**

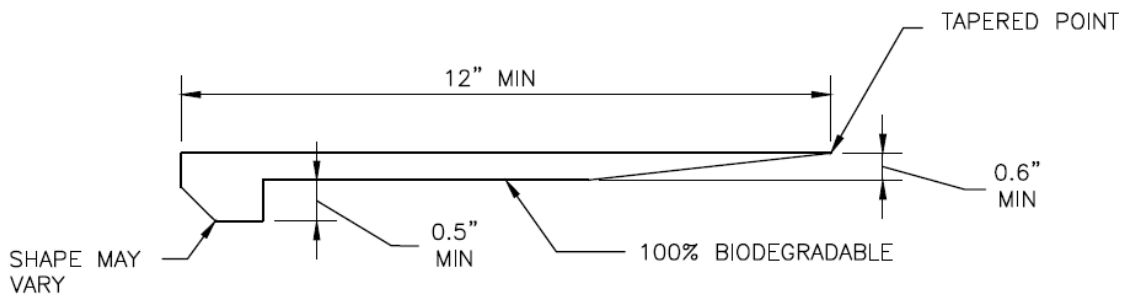
1. KEEP ALL WETLAND SOD MOIST AND SHADED UNTIL INSTALLED.
2. FOLLOW FINAL GRADING AND TOPSOIL PLACEMENT.
3. INSTALL FABRIC (4M COIR MAT) AND ANY WILLOW LIVE STAKES PER PLAN.
4. APPLY WETLAND SOD AS SOON AS IT IS AVAILABLE FROM SUPPLIER.
5. ABUT EDGES OF SOD SECTIONS AND SECURELY PIN IN PLACE WITH 8" STEEL LANDSCAPE STAPLES IF NEEDED TO SECURE UNTIL STAKED.
6. STAKE SOD 18" O.C. ON ALL EDGES AND THROUGHOUT THE BODY OF SOD WITH WOODEN STAKES. LEAVE 2-3" OF THE STAKE SHOWING ABOVE THE MAT.
7. ANY PREVIOUS STAKES IN SOD AREA TO BE POUNDED DOWN TO SURFACE PRIOR TO SOD PLACEMENT AND STAKING.
8. IN BACKWATER AREAS AND OTHER AREAS (NOTED ON PLAN) WHERE VELOCITIES APPROACH ZERO, STAKES MAY NOT BE NECESSARY.

**Figure 13-4. Wetland sod installation with staking**

DIAGONALLY CUT WOOD STAKES  
MADE FROM 2" X 4" DIMENSIONAL  
LUMBER, 2'-0" LENGTHS FOR COIR  
MAT AND 2'-6" LENGTHS TO SECURE  
BIOLOGS.

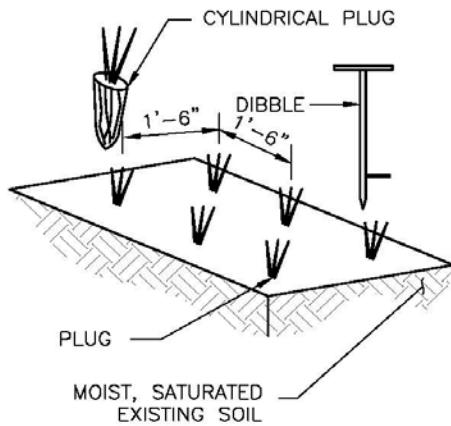


**CUT WOOD**

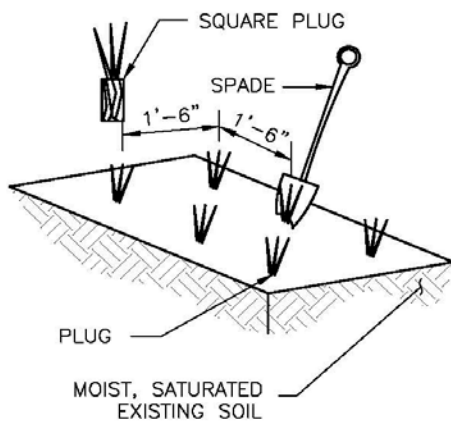


**PROPRIETARY**

**Figure 13-5. Stakes**

**NOTES**

1. DROP WOODEN DIBBLE STICK WITH APPROPRIATELY SIZED STEEL END INTO SOIL APPROXIMATELY 1'-6" FROM OTHER PLUGS.
2. STEP ON STEEL FOOT PLATE TO CREATE DEEPER HOLE. REMOVE DIBBLE STICK.
3. REMOVE WETLAND PLUG FROM CONTAINER AND PLANT ROOTS DOWN.
4. TAMP ON SOIL AROUND PLANT TO SECURE.

**CYLINDRICAL CONTAINER PLUGS****NOTES**

1. DROP SPADE INTO SOIL APPROXIMATELY 1'-6" FROM OTHER PLUGS.
2. STEP ON SPADE AND MOVE BACK AND FORTH TO CREATE AN OPEN POCKET LARGE ENOUGH FOR THE ROOT MASS TO BE INSTALLED FULLY WITHOUT HAVING TO BEND THE ROOTS.
3. REMOVE WETLAND PLUG FROM CONTAINER AND PLANT ROOTS DOWN SO THAT THE TOP OF THE ROOTS ARE JUST BELOW THE SOIL SURFACE IN THE HOLE.
4. TAMP ON SOIL AROUND PLANT TO SECURE.

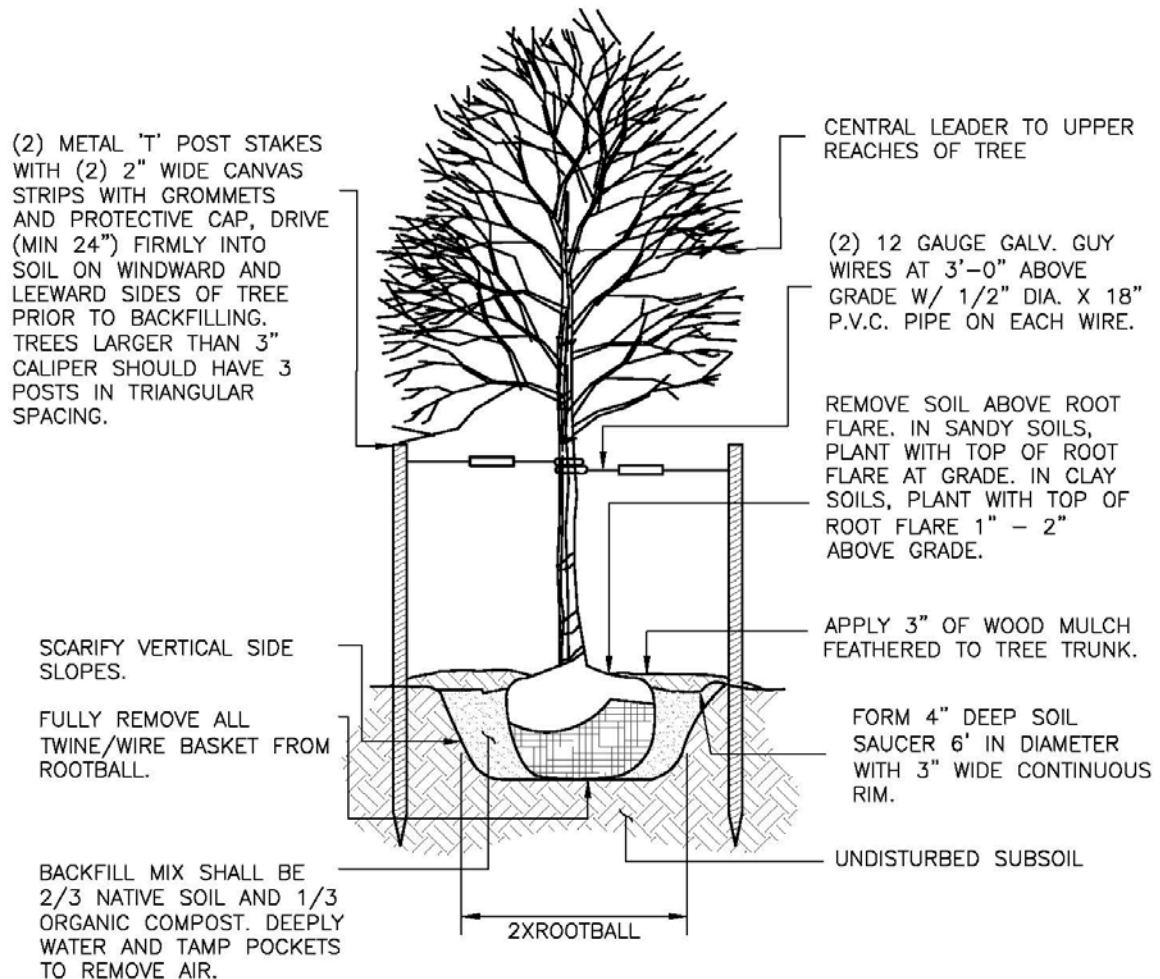
**SQUARE CONTAINER PLUGS****NOTES**

1. UPON ARRIVAL CHECK THAT WETLAND PLUGS ARE HEALTHY, MOIST, AND FREE OF INJURIES OR INSECT DAMAGE.
2. KEEP WETLAND PLUGS MOIST AND SHADED BEFORE PLANTING.
3. SOILS SHOULD BE MOIST TO SATURATED BEFORE PLANTING.
4. WATER THE PLANTED AREA AFTER PLANTING IF NEEDED.
5. INSTALL WATERFOWL PREDATION CONTROL AS NEEDED.

**Figure 13-6. Wetland plug planting**

**NOTES:**

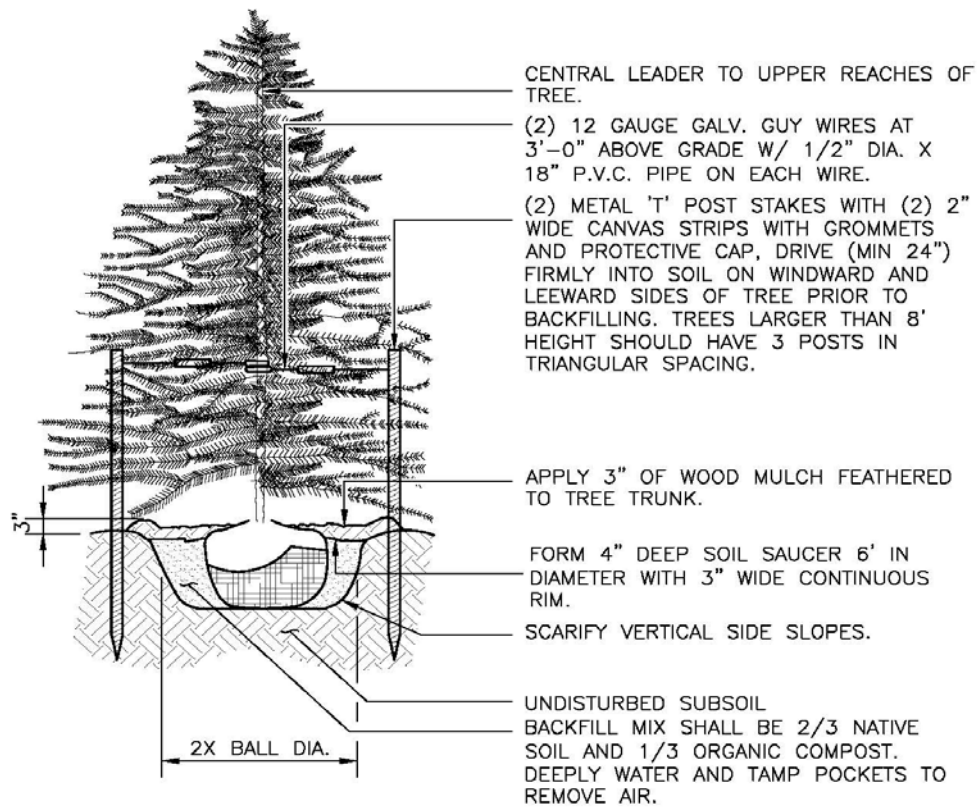
1. CHECK NATIVE SPECIES FOR ACCURACY PRIOR TO PLANTING.
2. KEEP PLANT MOIST AND SHADED IN MULCHED BEDS ON SITE UNTIL TIME OF PLANTING.
3. DO NOT DAMAGE OR CUT LEADER.
4. PRUNE ALL DAMAGED OR DEAD WOOD AFTER PLANTING, STAKING AND MULCHING.
5. KEEP CROWN SHAPE TYPICAL OF SPECIES. REMOVE ALL PLANTING TAGS, TAPE AND LABELS AFTER FINAL ACCEPTANCE BY LANDSCAPE ARCHITECT OR ECOLOGIST.
6. PROVIDE WILDLIFE PROTECTION AS NEEDED.
7. CUT AND REMOVE ALL WIRE/TWINE WRAPPING AND BURLAP.



**Figure 13-7. Deciduous tree planting**

**NOTES**

1. KEEP PLANT MOIST AND SHADED UNTIL PLANTING.
2. FULLY REMOVE ALL TWINE/WIRE BASKET FROM ROOTBALL.
3. PLANT TREE AT GRADE IN SANDY SOIL, 1"–2" HIGHER THAN GRADE IN CLAY SOIL.
4. DO NOT DAMAGE OR CUT LEADER.
5. PRUNE ALL DAMAGED OR DEAD WOOD AFTER PLANTING, STAKING AND MULCHING.
6. KEEP CROWN SHAPE TYPICAL OF SPECIES. REMOVE ALL PLANTING LABELS AFTER FINAL ACCEPTANCE BY LANDSCAPE ARCHITECT OR ECOLOGIST.
7. PROVIDE WILDLIFE PROTECTION AS NEEDED.



**Figure 13-8. Upland evergreen tree planting**

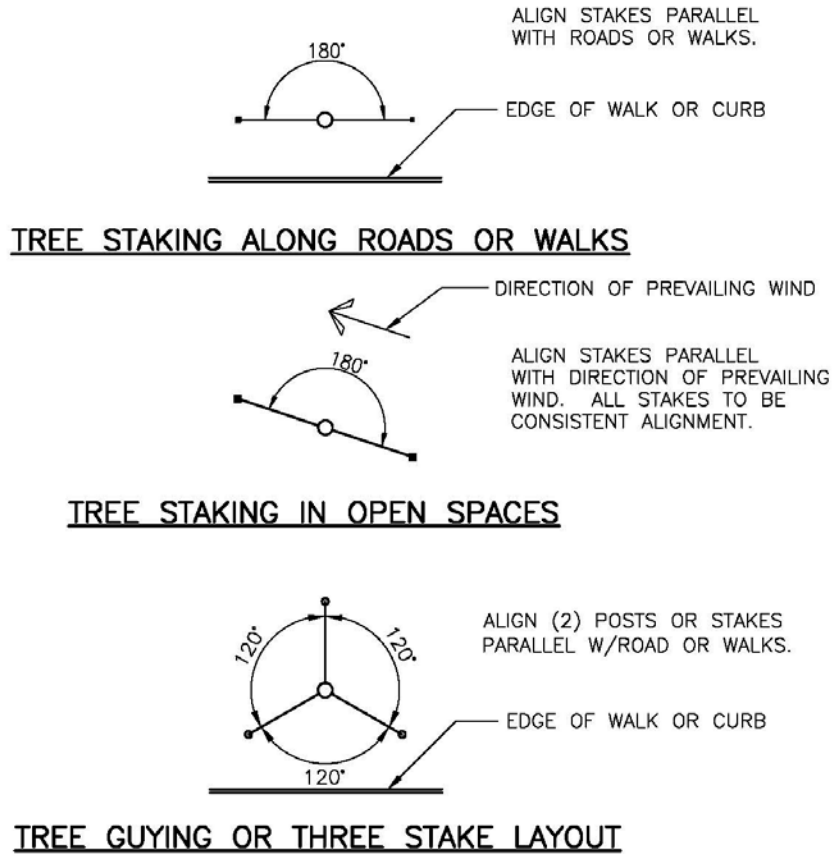
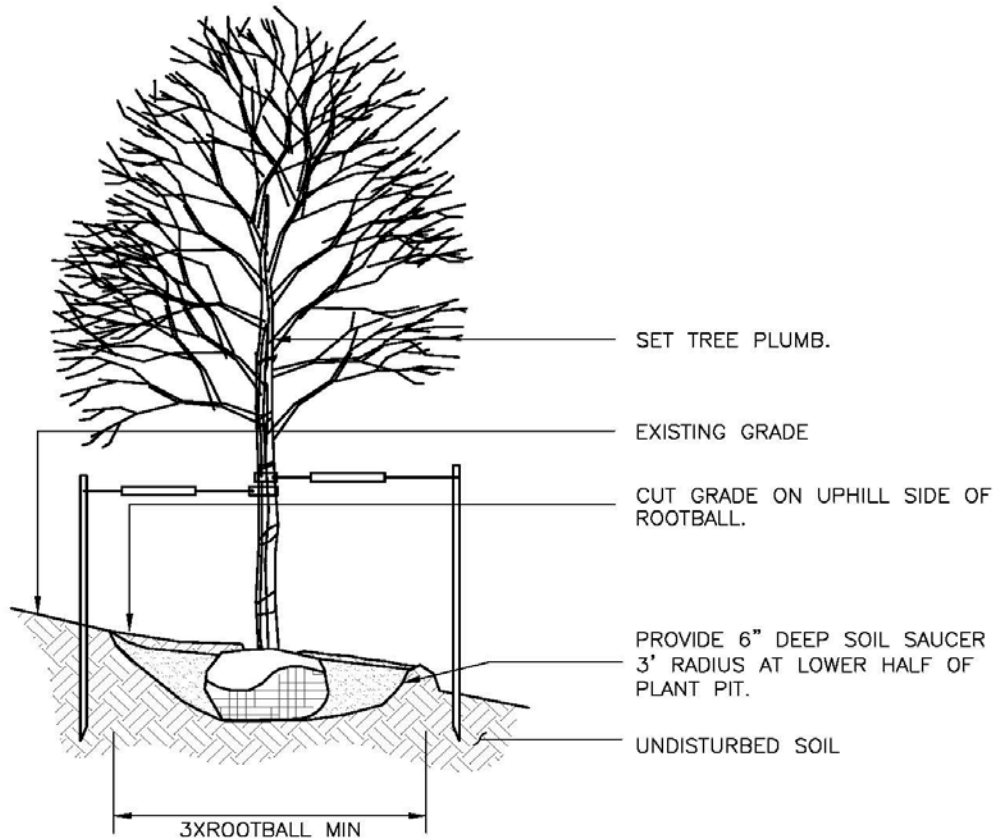


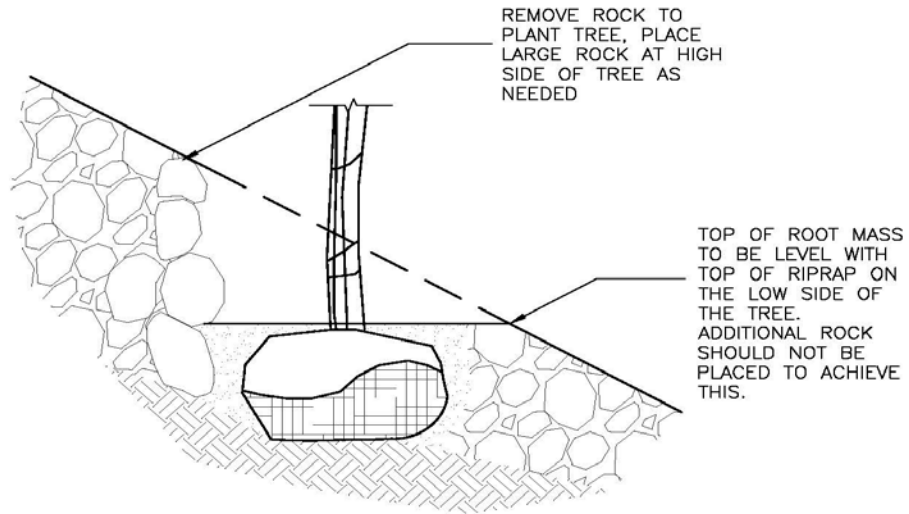
Figure 13-9. Tree stake layout



**NOTES**

1. KEEP PLANT MOIST AND SHADED UNTIL PLANTING.
2. REFER TO DECIDUOUS AND EVERGREEN TREE PLANTING DETAILS FOR ALL NOTES.
3. THIS INSTALLATION SHALL APPLY TO TREES PLANTED ON SLOPES 4:1 AND STEEPER.

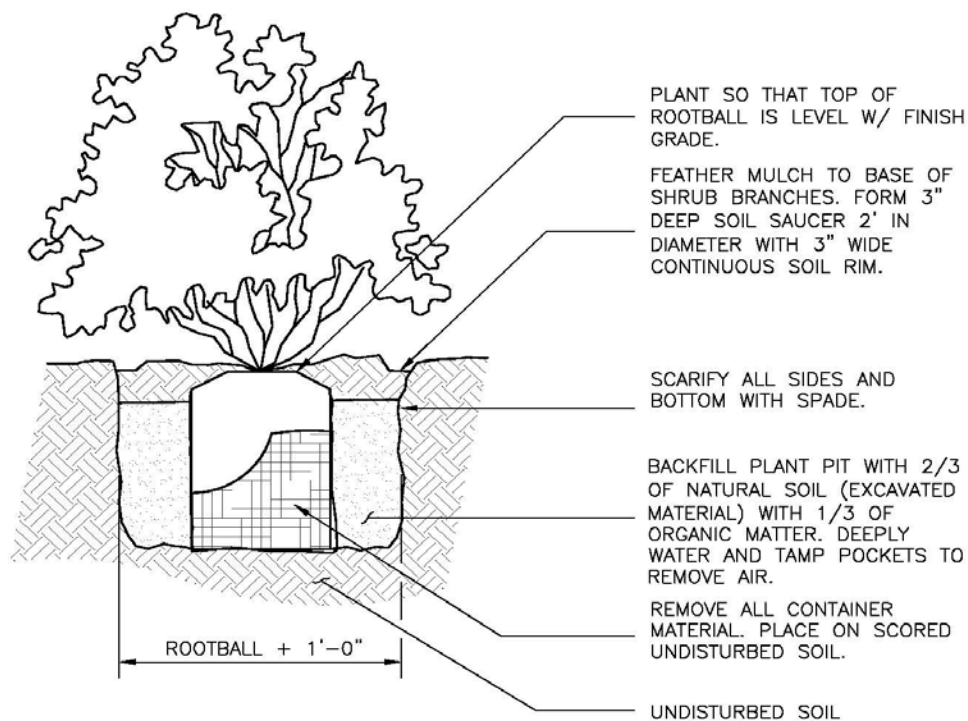
**Figure 13-11. Tree planting on slope**



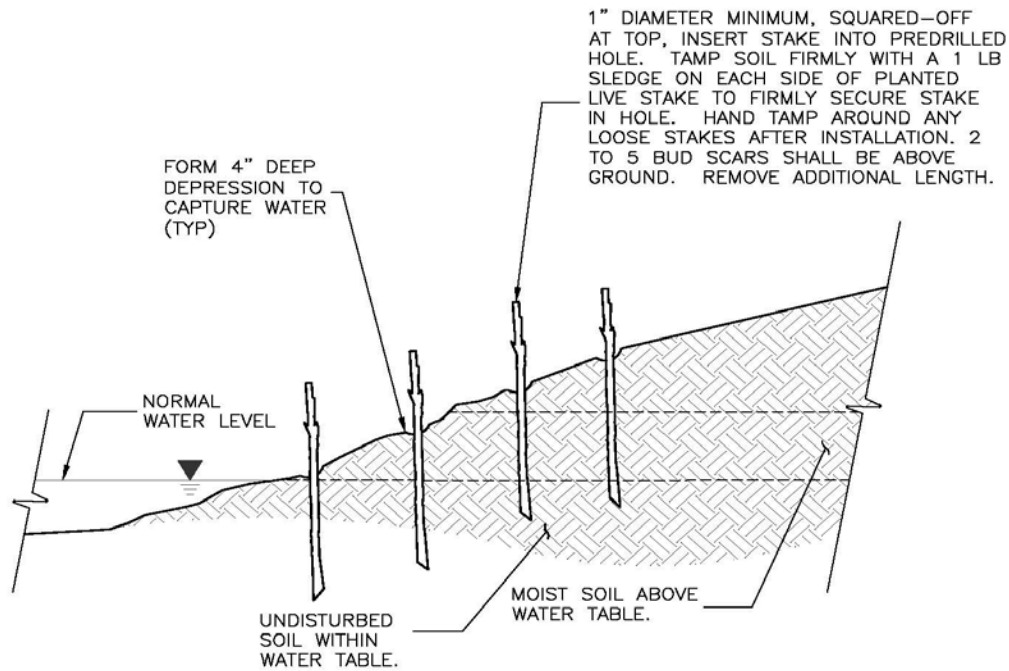
**Figure 13-12. Tree planting on riprap slope**

**NOTES**

1. KEEP PLANT MOIST AND SHADED UNTIL PLANTING.
2. FOR ROOT BOUND CONTAINER PLANTS, MAKE 4–5" DEEP VERTICAL CUTS INTO ROOT BALL EDGE AND PLANT IMMEDIATELY.
3. DO NOT CUT LEADER, PRUNE ALL DAMAGED OR DEAD WOOD AFTER PLANTING, STAKING AND MULCHING, KEEP CROWN SHAPE TYPICAL OF SPECIES, REMOVE ALL PLANTING LABELS AFTER FINAL ACCEPTANCE BY LANDSCAPE ARCHITECT OR ECOLOGIST.
4. PROVIDE WILDLIFE PROTECTION AROUND PLANTED SHRUB AS NEEDED.

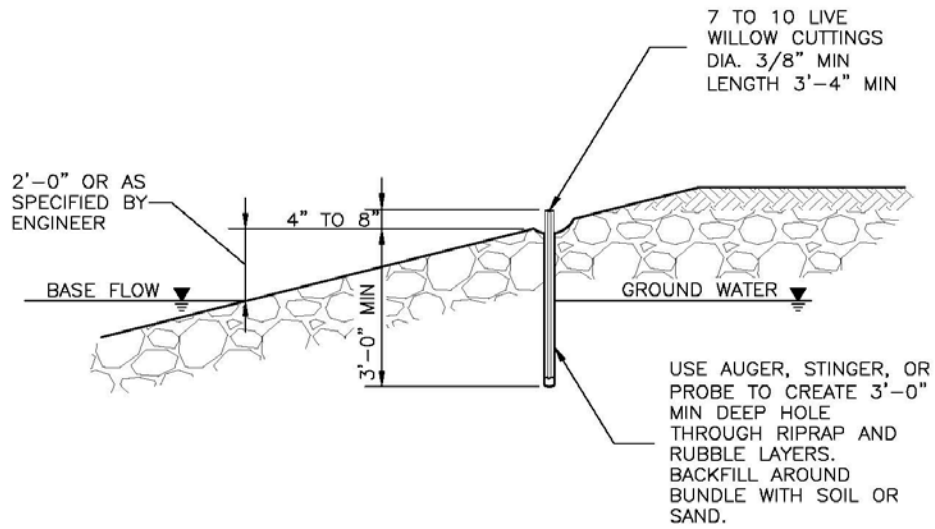


**Figure 13-13. Shrub planting container**

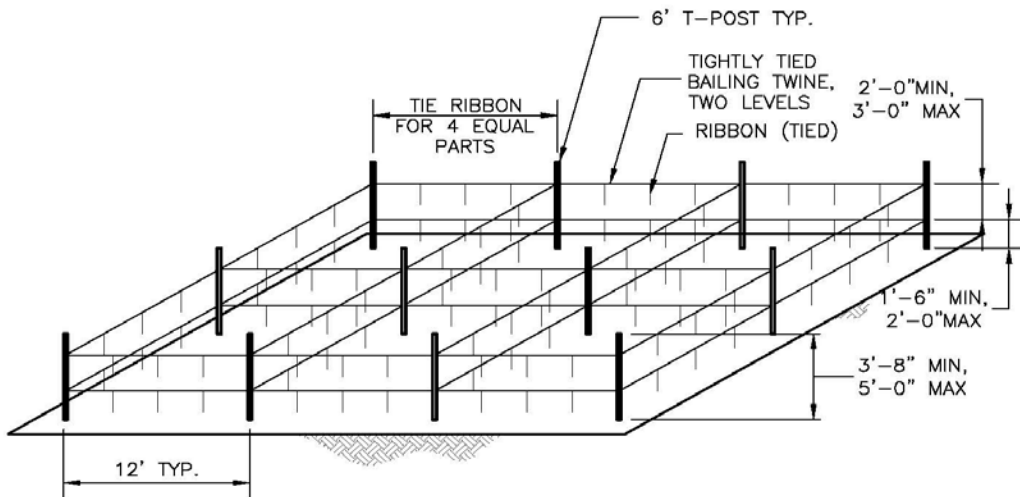
**NOTES**

1. HARVEST AND PLANT WILLOW LIVE STAKES DURING DORMANT SEASON
2. WILLOW STAKE SHALL HAVE CUT END ON AN ANGLE TO SIGNIFY PLANTING END.
3. USE HEALTHY, STRAIGHT, AND LIVE WOOD AT 2 TO 3 YEARS OLD.
4. MAKE CLEAN CUTS AND DO NOT DAMAGE STAKES OR SPLIT ENDS.
5. PLACE CUTTINGS IN WATER IMMEDIATELY AFTER HARVESTING.
6. SOAK CUTTINGS FOR 24 HOURS (MIN.) PRIOR TO INSTALLATION.
7. STORE CUT WILLOWS WITH LOWER ENDS IN WATER FOR NO LONGER THAN 7 DAYS BEFORE PLANTING.
8. LENGTH OF STAKES SHALL BE 2' (MIN.). PRE-DRILL HOLES WITH STEEL REBAR.
9. PLANT AT LEAST 3/4 LENGTH OF STAKE INTO MOIST SOIL.

**Figure 13-14. Willow live stakes planting**



**Figure 13-15. Willow bundle installation**



**Figure 13-16. Waterfowl grazing control**

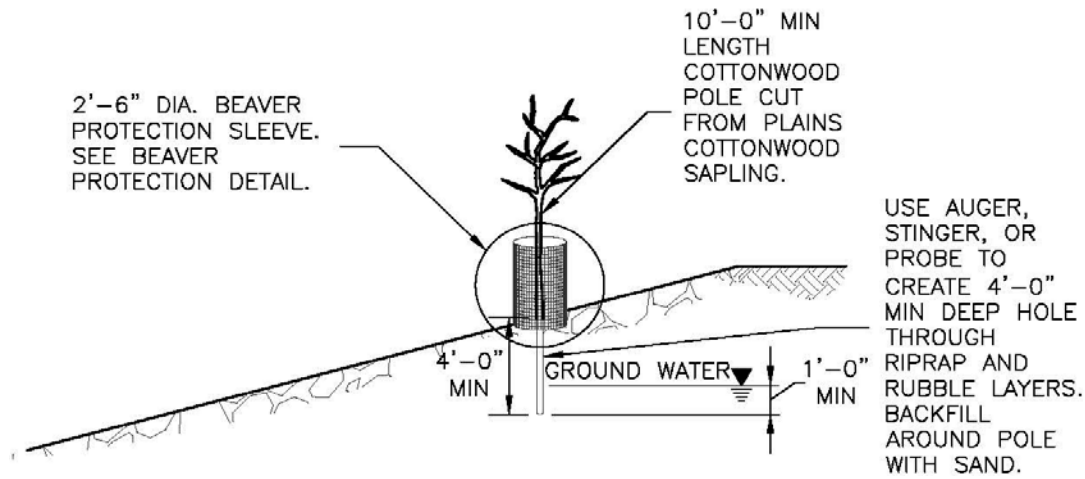


Figure 13-17. Cottonwood poling

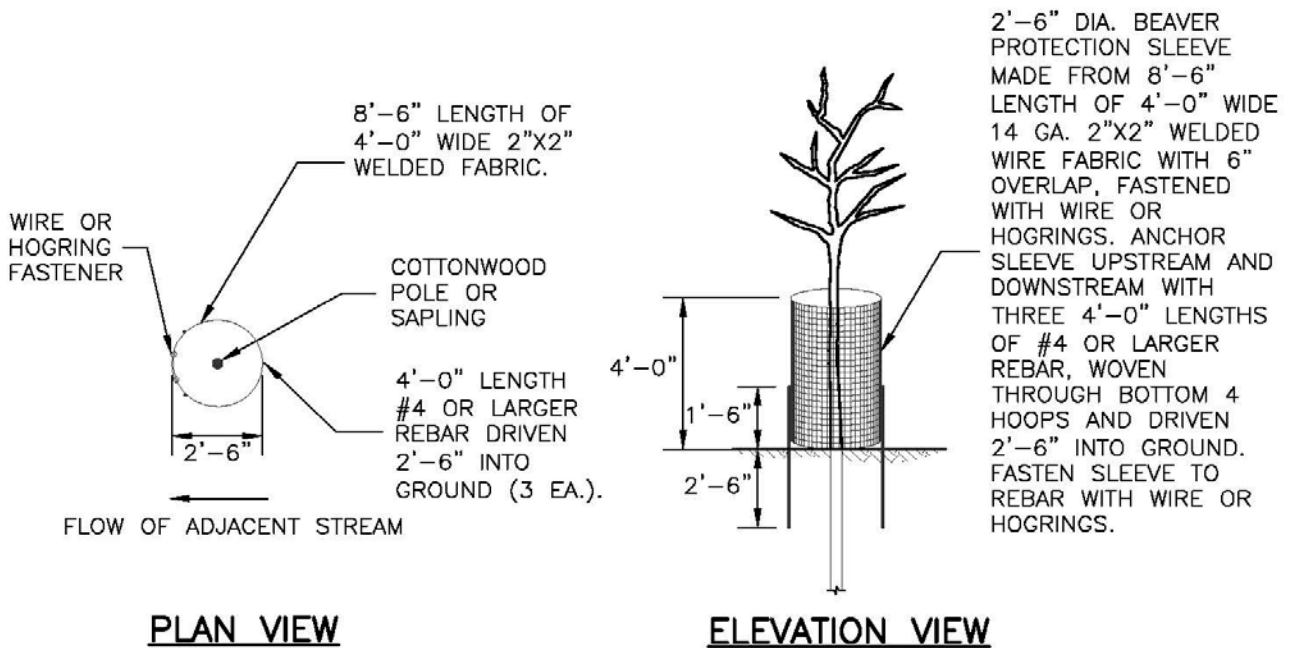


Figure 13-18. Beaver protection

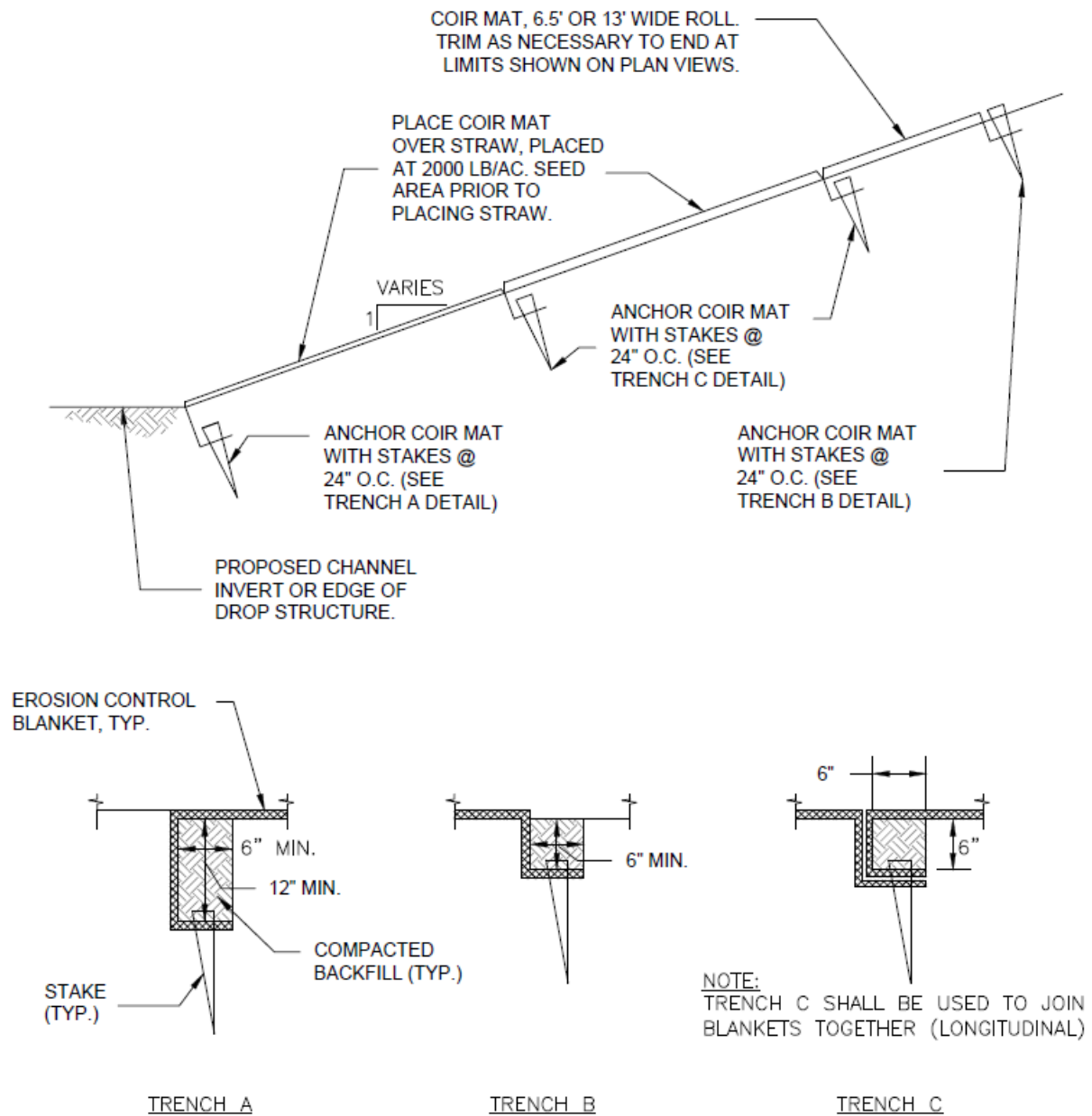


Figure 13-19. Coir mat placement and trenching detail

## Appendix A. Seed Mix Tables

### Upland Native Seed Mixes (drill seed rates)

**Table A-1. Upland area seed mix – loamy to clay soils**

Common Name	Scientific Name	Growth Season	Growth Form	% Mix	Lb/ac (PLS <sup>1</sup> )
<b>Grasses</b>					
Blue grama	<i>Bouteloua gracilis</i>	Warm	Sod	25	1.8
Sand dropseed	<i>Sporobolus cryptandrus</i>	Warm	Bunch	20	0.2
Sideoats grama	<i>Bouteloua curtipendula</i>	Warm	Sod	20	6.3
Western wheatgrass	<i>Pascopyrum smithii</i>	Cool	Sod	15	8.2
Buffalograss	<i>Bouteloua dactyloides</i>	Warm	Sod	10	10.7
Inland saltgrass	<i>Distichlis spicata</i>	Warm	Sod	5	0.6
<b>Herbaceous/Wildflowers</b>					
Pasture sage	<i>Artemisia frigida</i>			1	0.01
Blanket flower	<i>Gaillardia aristata</i>			1	0.5
Prairie coneflower	<i>Ratibida columnifera</i>			1	0.1
Purple prairieclover	<i>Dalea (Petalostemum) purpurea</i>			1	0.3
Blue flax	<i>Linum lewisii</i>			1	0.4
<b>TOTAL PLS POUNDS/ACRE</b>				<b>100</b>	<b>29.11</b>

<sup>1</sup>PLS = Pure Live Seed – If broadcast seeding, double the rate

**Table A-2. Upland area seed mix – sandy soil**

Common Name	Scientific Name	Growth Season	Growth Form	% Mix	Lb/ac (PLS <sup>1</sup> )
<b>Grasses</b>					
Switchgrass	<i>Panicum virgatum</i>	Warm	Sod/Bunch	15	2.3
Prairie sandreed	<i>Calamovilfa longifolia</i>	Warm	Sod	10	2.2
Sideoats grama	<i>Bouteloua curtipendula</i>	Warm	Sod	10	3.1
Blue grama	<i>Bouteloua gracilis</i>	Warm	Sod	10	0.7
Indian ricegrass	<i>Oryzopsis hymenoides</i>	Cool	Bunch	10	4.3
Western wheatgrass	<i>Pascopyrum smithii</i>	Cool	Sod	10	5.5
Little bluestem	<i>Schizachyrium scoparium</i>	Warm	Bunch	10	2.3
Sand dropseed	<i>Sporobolus cryptandrus</i>	Warm	Bunch	10	0.1
Green needlegrass	<i>Stipa viridula</i>	Cool	Bunch	10	3.3
<b>Herbaceous/Wildflowers</b>					
Pasture sage	<i>Artemisia frigida</i>			1	0.1
Blanket flower	<i>Gaillardia aristata</i>			2	0.9
Tansy aster	<i>Maceranthera tanacetifolia</i>			2	0.2
<b>TOTAL PLS POUNDS/ACRE</b>				<b>100</b>	<b>25</b>

<sup>1</sup>PLS = Pure Live Seed – If broadcast seeding, double the rate

**Table A-3. Upland/transitional area seed mix – alkali soil**

Common Name	Scientific Name	Growth Season	Growth Form	% Mix	Lb/ac (PLS <sup>1</sup> )
Blue grama	<i>Bouteloua gracilis</i>	Warm	Sod	20	1.5
Sideoats grama	<i>Bouteloua curtipendula</i>	Warm	Sod	15	4.7
Slender wheatgrass	<i>Elymus trachycaulus</i>	Cool	Bunch	15	5.7
Alkali sacaton	<i>Sporobolus airoides</i>	Warm	Sod/Bunch	15	0.5
Inland saltgrass	<i>Distichlis spicata</i>	Warm	Sod	15	1.7
Western wheatgrass	<i>Pascopyrum smithii</i>	Cool	Sod	10	5.5
Sand dropseed	<i>Sporobolus cryptandrus</i>	Warm	Bunch	10	0.1
<b>TOTAL PLS POUNDS/ACRE</b>				<b>100</b>	<b>19.7</b>

<sup>1</sup>PLS = Pure Live Seed – If broadcast seeding, double the rate

### Riparian Native Seed Mixes

**Table A-4. Riparian seed mix – loamy to clay soils**

(Recommended for middle to upper terraces and slopes above the 5-year flood elevations.)

Common Name	Scientific Name	Growth Season	Growth Form	% Mix	Lb/ac (PLS <sup>1</sup> )
<b>Grasses</b>					
Blue grama	<i>Bouteloua gracilis</i>	Warm	Sod	20	1.5
Sand dropseed	<i>Sporobolus cryptandrus</i>	Warm	Bunch	20	0.2
Switchgrass	<i>Panicum virgatum</i>	Warm	Sod/Bunch	20	3.2
Sideoats grama	<i>Bouteloua curtipendula</i>	Warm	Sod	15	4.7
Western wheatgrass	<i>Pascopyrum smithii</i>	Cool	Sod	10	5.5
Green needlegrass	<i>Nasella viridula</i>	Cool	Bunch	10	3.3
<b>Wildflowers</b>					
Smooth aster	<i>Aster laevis</i>			1	0.1
Louisiana sage	<i>Artemisia ludoviciana</i>			1	0.1
Showy goldeneye	<i>Heliomeris multiflora</i> (aka <i>Viguiera</i> )			1	0.1
Blanket flower	<i>Gaillardia aristata</i>			1	0.5
Prairie coneflower	<i>Ratibida columnifera</i>			1	0.1
<b>TOTAL POUNDS PLS/ACRE</b>				<b>100</b>	<b>19.3</b>

<sup>1</sup>PLS = Pure Live Seed – If broadcast seeding, double the rate

**Table A-5. Riparian area seed mix – sandy soil**

(Recommended for middle to upper terraces and slopes above 5-year flood elevations.)

Common Name	Scientific Name	Growth Season	Growth Form	% Mix	Lb/ac (PLS <sup>1</sup> )
Sand dropseed	<i>Sporobolus</i>	Warm	Bunch	20	0.2
Switchgrass	<i>Panicum virgatum</i>	Warm	Sod/Bunch	20	3.1
Blue grama	<i>Bouteloua gracilis</i>	Warm	Sod	15	1.1
Canada wildrye	<i>Elymus canadensis</i>	Cool	Bunch	10	5.2
Sand bluestem	<i>Andropogon hallii</i>	Warm	Bunch	10	5.3
Western wheatgrass	<i>Pascopyrum smithii</i>	Cool	Sod	10	5.5
Yellow Indiangrass	<i>Sorghastrum nutans</i>	Warm	Sod	10	3.5
<b>Wildflowers</b>					
Blanket flower	<i>Gaillardia aristata</i>			1	0.5
Rocky Mountain	<i>Penstemon strictus</i>			1	0.1
Purple prairie clover	<i>Dalea purpurea</i>			1	0.3
Mexican hat	<i>Ratibida columnifera</i>			1	0.1
Western yarrow	<i>Achillea millefolium</i>			1	0.02
<b>TOTAL PLS POUNDS/ACRE</b>				<b>100</b>	<b>24.92</b>

<sup>1</sup>PLS = Pure Live Seed – If broadcast seeding, double the rate**Table A-6. Riparian area seed mix – alkali soil**

(Recommended for middle to upper terraces and slopes above the 5-year flood elevations.)

Common Name	Scientific Name	Growth Season	Growth Form	% Mix	Lb/ac (PLS <sup>1</sup> )
Alkali sacaton	<i>Sporobolus airoides</i>	Warm	Bunch	25	0.9
Blue grama	<i>Bouteloua gracilis</i>	Warm	Sod	25	1.8
Inland saltgrass	<i>Distichlis spicata</i>	Warm	Sod	25	2.9
Streambank wheatgrass	<i>Elymus lanceolatus</i>	Cool	Sod	10	3.9
Western wheatgrass	<i>Pascopyrum smithii</i>	Cool	Sod	10	5.5
Buffalograss	<i>Bouteloua dactyloides</i>	Warm	Sod	5	5.4
<b>TOTAL PLS POUNDS/ACRE</b>				<b>100</b>	<b>20.4</b>

<sup>1</sup>PLS = Pure Live Seed – If broadcast seeding, double the rate

**Table A-7. Riparian/creek edge seed mix – moist to wet soils**

(Recommended for riparian streambank/low terraces below the 5-year flood elevation.)

Common Name	Scientific Name	Growth Season	Growth Form	% Mix	Lb/ac (PLS <sup>1</sup> )
<b>Grasses</b>					
Inland saltgrass	<i>Distichlis stricta</i>	Cool	Sod	15	1.7
Creeping spikerush	<i>Eleocharis palustris</i>	Cool	Sod	15	1.5
Baltic rush	<i>Juncus balticus</i>	Cool	Sod	15	0.1
Switchgrass	<i>Panicum virgatum</i>	Warm	Sod	12	1.9
Western wheatgrass	<i>Pascopyrum smithii</i>	Cool	Sod	8	4.4
Green needlegrass	<i>Nasella viridula</i>	Cool	Bunch	10	3.3
Prairie cordgrass	<i>Spartina pectinata</i>	Warm	Sod	10	3.1
Wooly sedge	<i>Carex lanuginosa</i>	Cool	Sod	5	1.0
Nebraska sedge	<i>Carex nebrascensis</i>	Cool	Sod	5	0.6
<b>Wildflowers</b>					
Wild Bergamot	<i>Monarda fistulosa</i>			1	0.1
Yarrow	<i>Achillea millefolium</i>			1	0.02
Blue vervain	<i>Verbena hastata</i>			2	0.1
Nuttall's sunflower	<i>Helianthus nuttallii</i>			1	0.2
<b>TOTAL PLS POUNDS/ACRE</b>					<b>18.02</b>

<sup>1</sup>PLS = Pure Live Seed – If broadcast seeding, double the rate

## Wetland Native Seed Mixes

**Table A-8. Wetland seed mix – loamy to sandy soils**  
(Recommended for detention ponds and less eroding wetland areas.)

Common Name	Scientific Name	Growth Season	Growth Form	% Mix	Wetland Indicator*	Lb/ac (PLS <sup>1</sup> )
<b>Grasses and Herbaceous Species</b>						
American Sloughgrass	<i>Beckmannia syzigachne</i>	Cool	Sod	15	OBL	0.8
Prairie cordgrass	<i>Spartina pectinata</i>	Warm	Sod	15	FACW	4.6
Switchgrass	<i>Panicum virgatum</i>	Warm	Sod/Bunch	15	FAC	2.3
Western wheatgrass	<i>Pascopyrum smithii</i>	Cool	Sod	10	FACU	5.5
Fowl mannagrass	<i>Glyceria striata</i>	Cool	Sod	10	OBL	3.3
Hardstem bulrush	<i>Scirpus acutus</i>			10	OBL	1.6
Baltic rush	<i>Juncus balticus</i>			10	OBL	0.1
Creeping spikerush	<i>Eleocharis palustris</i>			10	OBL	1.0
<b>Wildflowers</b>						
Blue vervain	<i>Verbena hastata</i>			2.5	FACW	0.1
Nuttall's sunflower	<i>Helianthus nuttallii</i>			2.5	FAC	0.5
<b>TOTAL PLS POUNDS/ACRE</b>				<b>100</b>		<b>19.8</b>

<sup>1</sup>PLS = Pure Live Seed – If broadcast seeding, double the rate

**Table A-9. Wetland seed mix – clay and alkali soils**  
(Recommended for detention ponds and wetland areas.)

Common Name	Scientific Name	Growth Season	Growth Form	% Mix	Wetland Indicator*	Lb/ac (PLS <sup>1</sup> )
<b>Grasses and Herbaceous Species</b>						
Alkali sacaton	<i>Sporobolus airoides</i>	Warm	Bunch	10	FAC	0.4
Inland saltgrass	<i>Distichlis spicata</i>	Warm	Sod	10	FACW	1.2
Nuttall's alkaligrass	<i>Puccinellia nuttalliana</i>	Cool	Bunch	10	OBL	0.2
Prairie cordgrass	<i>Spartina pectinata</i>	Warm	Sod	10	FACW	3.0
Slender wheatgrass	<i>Elymus trachycaulus spp.</i>	Cool	Bunch	10	FACU	3.8
Western wheatgrass	<i>Pascopyrum smithii</i>	Cool	Sod	10	FACU	5.5
Fowl mannagrass	<i>Glyceria striata</i>	Cool	Sod	10	OBL	3.3
Hardstem bulrush	<i>Scirpus acutus</i>			10	OBL	1.6
Baltic rush	<i>Juncus balticus</i>			10	OBL	0.1
Creeping spikerush	<i>Eleocharis palustris</i>			10	OBL	1.0
<b>TOTAL PLS POUNDS/ACRE</b>						<b>20.1</b>

<sup>1</sup>PLS = Pure Live Seed – If broadcast seeding, double the rate

Note: Wildflowers species not recommended for clay or alkali soils.

**Wetland Indicator Key for Tables A-8 and A-9:**

FAC = Facultative – Equally occurs in both wetlands and uplands.

FACU = Facultative Upland – Occurs mostly in uplands, but can occur in wetlands about 1/3 of the time.

FACW = Facultative Wetlands – Occurs mostly in wetlands, but can occur in uplands about 1/3 of the time.

OBL = Obligate Wetlands – Almost always occurs in wetlands.

UPL = Uplands – Almost always occurs in uplands.

### Temporary Native Seed Mixes

Note: A sterile annual grass such as a wheat X wheatgrass hybrid may be used as temporary grass cover in areas that are likely to be disturbed again. A sterile annual cover crop is generally less expensive and quicker to establish than a temporary native grass seed mix. The native grass seed mixes as shown below offer an alternative to seeding with annual sterile grasses and can be used in areas where there may be limited future disturbance therefore warranting a temporary seed mix that can become permanent.

**Table A-10. Upland area temporary seed mix – loamy to clay soils**

Common Name	Scientific Name	Growth Season	Growth Form	% of Seed Mix	Lb/ac (PLS <sup>1</sup> )
Slender wheatgrass	<i>Elymus trachycaulus spp.</i>	Cool	Bunch	20	5
Green needlegrass	<i>Nasella viridula</i>	Cool	Bunch	20	4.4
Western wheatgrass	<i>Pascopyrum smithii</i>	Cool	Sod	20	7.3
Arizona fescue	<i>Festuca arizonica</i>	Cool	Bunch	20	1.5
Sideoats grama	<i>Bouteloua curtipendula</i>	Warm	Bunch/Sod	20	4.2
<b>TOTAL PLS POUNDS/ACRE</b>				<b>100</b>	<b>22.4</b>

<sup>1</sup>PLS = Pure Live Seed – If broadcast seeding, double the rate

**Table A-11. Upland area temporary seed mix – sandy soil**

Common Name	Scientific Name	Growth Season	Growth Form	% of Seed Mix	Lb/ac (PLS <sup>1</sup> )
Sand lovegrass	<i>Eragrostis trichodes</i>	Warm	Bunch	20	0.5
Sand bluestem	<i>Andropogon hallii</i>	Warm	Sod	20	7.1
Prairie sandreed	<i>Calamovilfa longifolia</i>	Warm	Sod	15	2.2
Sand dropseed	<i>Sporobolus cryptandrus</i>	Warm	Bunch	15	0.1
Needle and Thread	<i>Hesperostipa comata spp. comata</i>	Cool	Bunch	15	5.2
Red three-awn	<i>Aristida purpurea var. longiseta</i>	Warm	Bunch	15	2
<b>TOTAL PLS POUNDS/ACRE</b>				<b>100</b>	<b>17.1</b>

<sup>1</sup>PLS = Pure Live Seed – If broadcast seeding, double the rate

**Table A-12. Upland area temporary seed mix –combination of soil types**

Common Name	Scientific Name	Growth Season	Growth Form	% of Seed Mix	Lb/ac (PLS <sup>1</sup> )
Slender wheatgrass	<i>Elymus trachycaulus spp.</i>	Cool	Bunch	25	6.3
Canada wildrye	<i>Elymus canadensis</i>	Cool	Bunch	15	5.2
Little bluestem	<i>Schizachyrium scoparium</i>	Warm	Bunch	15	2.3
Thickspike wheatgrass	<i>Elymus lanceolatus ssp. lanceolatus</i>	Cool	Sod	15	3.9
Sixweeks fescue	<i>Vulpia octoflora</i>	Cool	Annual/ Bunch	15	0.6
Bottlebrush squirreltail	<i>Elymus elymoides</i>	Cool	Bunch	15	3.1
<b>TOTAL PLS POUNDS/ACRE</b>				<b>100</b>	<b>21.4</b>

<sup>1</sup>PLS = Pure Live Seed – If broadcast seeding, double the rate

**Table A-13. Moist to wet area temporary seed mix – combination of soil types**

Common Name	Scientific Name	Growth Season	Growth Form	% of Seed Mix	Lb/ac (PLS <sup>1</sup> )
Streambank wheatgrass	<i>Elymus lanceolatus ssp. psammophilus</i>	Cool	Sod	20	5.1
Slender wheatgrass	<i>Elymus trachycaulus spp.</i>	Cool	Bunch	15	3.8
Switchgrass	<i>Panicum virgatum</i>	Warm	Sod/Bunch	15	1.5
American	<i>Beckmannia syzigachne</i>	Cool	Sod	15	0.5
Bluejoint reedgrass	<i>Calamagrostis canadensis</i>	Cool	Sod	15	0.3
Fowl mannagrass	<i>Glyceria striata</i>	Cool	Sod	10	2.2
Inland saltgrass	<i>Distichlis spicata</i>	Warm	Sod	10	0.8
<b>TOTAL PLS POUNDS/ACRE</b>				<b>100</b>	<b>14.2</b>

<sup>1</sup>PLS = Pure Live Seed – If broadcast seeding, double the rate